



# CITY OF LEEDS, ALABAMA

## REGULAR COUNCIL MEETING AGENDA

Leeds Civic Center Meeting Room -1000 Park Drive, Leeds, Alabama 35094

January 06, 2020 @ 6:00 PM

---

### CALL COUNCIL MEETING TO ORDER

### ROLL CALL / INVOCATION / PLEDGE OF ALLEGIANCE

### PUBLIC HEARING

*Anyone wishing to address the Council during the Public Comment section of the meeting must sign in with the City Clerk to provide their name and address.*

- [1.](#) Z-2019-008: A request for the Rezoning of a Certain Property at 1730 Jones Street from R-2 (Single Family Residential District) to R-5 (Garden Home District)
- [2.](#) Consider Determination of Certain Conditions to be an Annoyance and Public Nuisance in Violation of Chapter 32 of the Code of Ordinances at 1042 Brian Drive
- [3.](#) Consider Tax Abatement Agreement with Hubbell Power Systems Inc at 1612 Moores Street
- [4.](#) Consider Tax Abatement Agreement with Hubbell Power Systems Inc at 8100 Churchill Avenue

### APPROVE COUNCIL MINUTES

- [5.](#) Minutes from December 02, 2019 Meeting

### REPORTS OF STANDING COMMITTEES OR SPECIAL BOARDS:

6. Finance Committee Report: Linda Miller
7. Public Safety Committee Report: Kenneth Washington
8. Public Works Committee Report: Ryan Bell

### REPORTS OF OFFICERS:

9. Mayor's Report: Mayor David Miller
- [10.](#) Police Department: Chief Atkinson
- [11.](#) Fire Department: Chief Parsons
- [12.](#) Library: Library Director Carden  
Snapshot of Library accomplishments in FY 18/19  
Alabama Public Library 2018 Survey  
Alabama Public Library 2019 Survey
13. Municipal Court: Magistrate Roberts
- [14.](#) Development Services Department: Zoning Administrator Watson
15. Public Works Department: Public Works Director Warren

**OLD BUSINESS:****NEW BUSINESS:**

- [16.](#) Ordinance 2019-12-01 (Carried over from the canceled meeting - December 16, 2019) Consider Establishing Post-Construction Best Management Practices for Permanent Storm Water Control Structures (Budget Neutral)
- [17.](#) Resolution 2019-12-02 (Carried over from the canceled meeting - December 16, 2019) Consider Adoption and Ratification of Monthly (November 2019) City Expenditures/Payables
- [18.](#) Resolution 2019-12-03 (Carried over from the canceled meeting - December 16, 2019) Consider Authorizing and Approving Library Collection Development Grant (Budgeted Item)
- [19.](#) Resolution 2019-12-04 (Carried over from the canceled meeting - December 16, 2019) Consider Authorizing and Approving Supplemental Insurance Benefits for City Career Firefighters  
  
Alabama First Respondents Benefit Program - Mandated by State Law - Budget Adjustment (No New Funds Requested - General Fund)
- [20.](#) Ordinance 2020-01-01 Consider Determination of Assenting to the Rezoning at 1730 Jones Street (Site address only)
- [21.](#) Resolution 19-001868 Consider Determination of Certain Conditions to be an Annoyance and Public Nuisance in Violation of Chapter 32 of the Code of Ordinances at 1042 Brian Drive
- [22.](#) Resolution 2020-01-01 Consider Animal Control and Pound Services Contract (Budgeted Item)
- [23.](#) Resolution 2020-01-02 Consider Awarding Bid for 2020 Brush Truck Fire Apparatus (Budgeted Item)
- [24.](#) Consider 2020-01-03 Consider Budget Adjustment - Leeds Tree Commission (Non-Budgeted Item)
- [25.](#) Consider 2020-01-04 Consider Adoption and Ratification of Monthly (December 2019) City Expenditures/Payables
- [26.](#) Consider 2020-01-05 Consider Budget Amendments - City Projects (Non-Budgeted Item)
- [27.](#) Resolution 2020-01-06 Consider Tax Abatement Agreement with Hubbell Power Systems Inc. at 1612 Moores Street (Budget Neutral)
- [28.](#) Resolution 2020-01-07 Consider Tax Abatement Agreement with Hubbell Power Systems Inc. at 8100 Churchill Avenue (Budget Neutral)

**PUBLIC COMMENTS**

*All comments are to be limited to 2 minutes*

**ADJOURNMENT**

---

In compliance with the Americans with Disabilities Act, those requiring accommodation for Council meetings should notify the City Clerk's Office at least 24 hours prior to the meeting at 205-699-2585.

**Item Attachment Documents:**

- 1. Z-2019-008:** A request for the Rezoning of a Certain Property at 1730 Jones Street from R-2 (Single Family Residential District) to R-5 (Garden Home District)

# NOTICE OF PUBLIC HEARING

City of Leeds  
City Council  
Application for Rezoning

**APPLICATION**

An application has been filed with the City of Leeds requesting the **Rezoning** of a certain parcel of property from R-2 Single Family Residential District to R-5, Garden Home District.

**City Council**

The City Council makes the final determination of this request for rezoning. Appeals to the decision of the City Council are made to Circuit Court of (in this instance) Jefferson County and St. Clair Co.

<b>CASE #:</b>	<b>Z-2019-008</b>
<b>APPLICANT NAME:</b>	<b>MICHAEL MYRICK &amp; JANIE MYRICK</b>
<b>PROPERTY OWNER:</b>	<b>MYRICK JACK A JR &amp; JANIE P; MYRICK MICHAEL G ETAL</b>
<b>TAX PARCEL ID:</b>	<b>2605161001037000; 2605161001042000; 2605161001040000; 2500164001001.000</b>
<b>SITE ADDRESS:</b>	<b>1730 Jones St., Leeds, AL 35094 – Site Only Jefferson CO &amp; St. Clair Co</b>
<b>CURRENT ZONING:</b>	<b>R-2, SINGLE FAMILY RESIDENTIAL DISTRICT</b>

**NOTICE IS HEREBY GIVEN** that the City Council will hold a public hearing on the proposed rezoning request.

The hearing is scheduled on

- Date:** Monday, January 6, 2020
- Time:** 6:00 pm
- Place:** Leeds Civic Center Meeting Room  
1000 Park Drive  
Leeds, AL 35094

**Public Information:** Any interested persons or their representative may appear at the meeting and comment on the application. **Comments are limited to two (2) minutes.** All comments should be directed to the council and please refrain from repeating statements made by previous speakers. Written comments may be mailed or emailed to the Council.

For more information about the application and related issues or to schedule an appointment:

- Contact Person:** Brad Watson
- E-mail:** bwatson@leedsalabama.gov
- Phone:** (205) 699-0907
- Mailing Address:** Leeds City Council – Rezoning Case Z-2019-008  
% Development Services  
1404 9<sup>th</sup> Street  
Leeds, Al 35094

**ORDINANCE NO. 2020-01-01**

**ORDINANCE ASSENTING TO THE REZONING OF CERTAIN PROPERTY OR PARCEL FROM R-2, SINGLE FAMILY DISTRICT TO R-5, GARDEN HOME DISTRICT IN THE CITY OF LEEDS, ALABAMA**

**WHEREAS**, the Planning Commission of the City of Leeds, Alabama has received a request to amend the City's Official Zoning Map, and has made, a report of their recommendations concerning the rezoning of the following parcel of property from R-2, Single Family District to R-5, Garden Home District; and

**WHEREAS**, the City of Leeds City Council held a formal public hearing for the purpose of considering an ordinance to amend the zoning map of the City in accordance with said zoning request on January 6, 2020; and

<b>CASE #:</b>	<b>Z-2019-008</b>
<b>APPLICANT NAME:</b>	<b>MICHAEL MYRICK &amp; JANIE MYRICK</b>
<b>PROPERTY OWNER:</b>	<b>MYRICK JACK A JR &amp; JANIE P; MYRICK MICHAEL G ETAL</b>
<b>TAX PARCEL ID:</b>	<b>2605161001037000; 2605161001042000; 2605161001040000; 2500164001001.000</b>
<b>SITE ADDRESS:</b>	<b>1730 Jones St., Leeds, AL 35094 – Site Only Jefferson CO &amp; St. Clair Co</b>
<b>CURRENT ZONING:</b>	<b>R-2, SINGLE FAMILY RESIDENTIAL DISTRICT</b>
<b>PROPOSED ZONING:</b>	<b>R-5, GARDEN HOME DISTRICT</b>

**WHEREAS**, Resolution and Proposed Ordinance were published in accordance with State Law and City Ordinance by posting in four (4) conspicuous places.

**NOW, THEREFORE BE IT ORDAINED BY THE CITY COUNCIL OF THE CITY OF LEEDS, ALABAMA, AS FOLLOWS:**

The City's Official Zoning Map shall be amended to rezone the above listed parcel of property from R-2, Single Family District to R-5, Garden Home District according to the City's current zoning regulations.

**READ, APPROVED AND ADOPTED** at a regular meeting of the City Council of the City of Leeds, Alabama on this this the day of January 6, 2020.

**BE IT FURTHER ORDAINED** that the Mayor and City staff shall have the full authority to do those things, perform those functions, and to sign necessary documentation in order to carry out the actions so authorized herein.

**BE IT FURTHER ORDAINED**, that the provisions of this Ordinance are severable if any part of this Ordinance is determined by a court of law to be invalid, unenforceable or unconstitutional, such determination shall not affect any other part of this Ordinance.

AYES:

NAYS:

ABSENT FROM VOTING:

ABSTAIN:

CITY OF LEEDS, ALABAMA

\_\_\_\_\_  
David Miller, MAYOR

\_\_\_\_\_  
DATE

ATTEST:

\_\_\_\_\_  
Toushi Arbitelle, City Clerk

I, Toushi Arbitelle, City Clerk of the City of Leeds, hereby certify that the above Ordinance was duly adopted by the City Council of the City of Leeds at a regular meeting held on the 6<sup>th</sup> day of January 2020.

\_\_\_\_\_  
Toushi Arbitelle, City Clerk

7

Z-2019-008

1730 JONES ST.

260516001037000;2605161001042000;2605161001040000;  
250016400100100

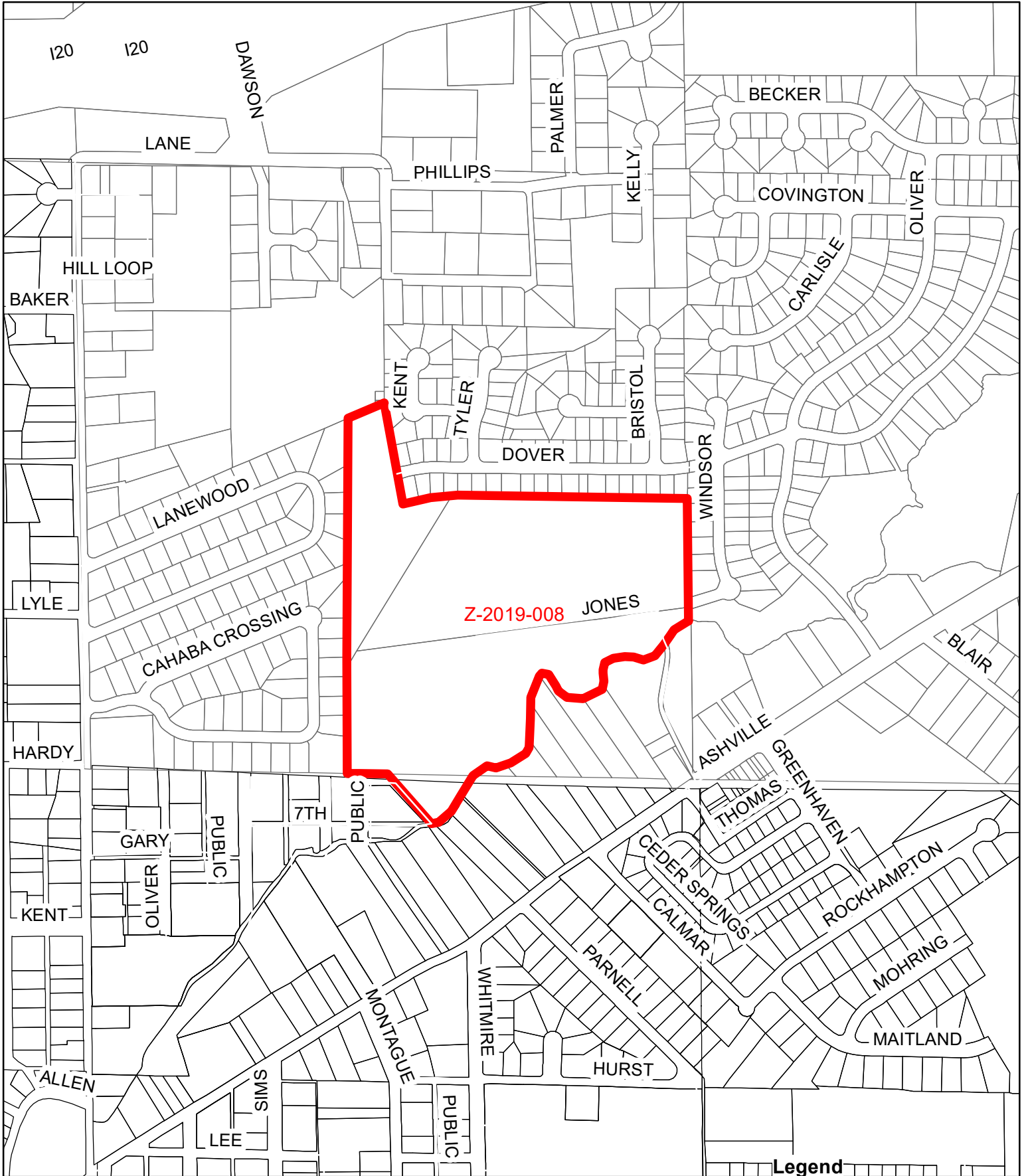

This instrument was prepared by

(VOL 93 PAGE 625)

REAL 452 PAGE 3

(Name) Willard O. Jackson, Attorney

(Address) Leeds, Alabama

Form 1-1-1 Rev. 1-66

WARRANTY DEED, JOINTLY FOR LIFE WITH REMAINDER TO SURVIVOR—LAWYERS TITLE INSURANCE CORPORATION, Birmingham, Alabama

STATE OF ALABAMA }  
JEFFERSON COUNTY } KNOW ALL MEN BY THESE PRESENTS,

That in consideration of Ten and NO/100-----(\$10.00)-----DOLLARS

and other good and valuable consideration to the undersigned grantor or grantors in hand paid by the GRANTEEES herein, the receipt whereof is acknowledged, we,

Edwin G. Goss and wife, Jo Ann M. Goss

(herein referred to as grantors) do grant, bargain, sell and convey unto

John A. Myrick, Jr. and wife, Janie Patton Myrick

(herein referred to as GRANTEEES) for and during their joint lives and upon the death of either of them, then to the survivor of them in fee simple, together with every contingent remainder and right of reversion, the following described real estate situated in Jefferson and St. Clair County, Alabama to-wit:

Parcel #26-05-16-1-001-042.000  
From the SW corner SE $\frac{1}{4}$  of NE $\frac{1}{4}$  of Sec. 16, T 17 S, R 1 E, the point of beginning of the within described property, run South 88° 48' W, 150.00 feet; thence North 3° 26' W, 554.98 feet; thence North 80° 42' E, 551.96 feet; thence North 80° 27' E, 956.42 feet to point 20 feet west of east line of said SE $\frac{1}{4}$  of NE $\frac{1}{4}$ ; thence South 2° 45' E, 71.00 feet to the center of Cahaba Creek; thence follow the center of said creek southwesterly to where the said creek intersects the south line of the SE $\frac{1}{4}$  of the NE $\frac{1}{4}$  of Sec. 16, T 17, R 1; thence west along the south line of said SE $\frac{1}{4}$  of the NE $\frac{1}{4}$  to the point of beginning, being a part of the SE $\frac{1}{4}$  of NE $\frac{1}{4}$  and SW $\frac{1}{4}$  of NE $\frac{1}{4}$  of Sec. 16, T 17 S, R 1 E, St. Clair County, Alabama.

A L S O

Parcel #25 00 16 4 001 001.000  
Part of the NE $\frac{1}{4}$  of the SE $\frac{1}{4}$  of Sec. 16, T 17 S, R 1 E, situated in Jefferson County, Alabama, more particularly described as follows:

Begin at the NW corner of said  $\frac{1}{4}$ - $\frac{1}{4}$  section, run thence eastwardly along the north line of said  $\frac{1}{4}$ - $\frac{1}{4}$  section to the center line of Cahaba Creek; run thence southwestwardly along the center line of said Cahaba Creek to a point which lies south 47° 56' East, 310.86 feet from the NW corner of said  $\frac{1}{4}$ - $\frac{1}{4}$  section; run thence North 47° 56' West for a distance of 310.86 feet to the point of beginning.

TO HAVE AND TO HOLD to the said GRANTEEES for and during their joint lives and upon the death of either of them, then to the survivor of them in fee simple, and to the heirs and assigns of such survivor forever, together with every contingent remainder and right of reversion.

And I (we) do for myself (ourselves) and for my (our) heirs, executors, and administrators covenant with the said GRANTEEES, their heirs and assigns, that I am (we are) lawfully seized in fee simple of said premises; that they are free from all encumbrances, unless otherwise noted above; that I (we) have a good right to sell and convey the same as aforesaid; that I (we) will and my (our) heirs, executors and administrators shall warrant and defend the same to the said GRANTEEES, their heirs and assigns forever, against the lawful claims of all persons.

IN WITNESS WHEREOF, WE have hereunto set OUR hand(s) and seal(s), this 29th day of 29 July, 1968

WITNESS:

Douglas L. Liggins (Seal)  
Charles Murray (Seal)

Edwin G. Goss (Seal)  
Jo Ann M. Goss (Seal)





(N) Willard O. Jackson, Attorney

(A) 9 Leeds, Alabama

Form 1-1-5 Rev. 1-66

WARRANTY DEED, JOINTLY FOR LIFE WITH REMAINDER TO SURVIVOR—LAWYERS TITLE INSURANCE CORPORATION, Birmingham, Alabama

STATE OF ALABAMA } KNOW ALL MEN BY THESE PRESENTS,  
JEFFERSON COUNTY }

That in consideration of Ten and NO/100-----(\$10.00)-----DOLLARS

and other good and valuable consideration to the undersigned grantor or grantors in hand paid by the GRANTEES herein, the receipt whereof is acknowledged, we, Edwin G. Goss and wife, Jo Ann M. Goss (herein referred to as grantors) do grant, bargain, sell and convey unto John A. Myrick, Jr. and wife, Janie Patton Myrick

(herein referred to as GRANTEES) for and during their joint lives and upon the death of either of them, then to the survivor of them in fee simple, together with every contingent remainder and right of reversion, the following described real estate situated in Jefferson and St. Clair County, Alabama to-wit:

From the SW corner SE 1/4 of NE 1/4 of Sec. 16, T 17 S, R 1 E, the point of beginning of the within described property, run South 88° 48' W, 150.00 feet; thence North 3° 26' W, 554.98 feet; thence North 80° 42' E, 551.96 feet; thence North 80° 27' E, 956.42 feet to point 20 feet west of east line of said SE 1/4 of NE 1/4; thence South 2° 45' E, 71.00 feet to the center of Cahaba Creek; thence follow the center of said creek southwesterly to where the said creek intersects the south line of the SE 1/4 of the NE 1/4 of Sec. 16, T 17, R 1; thence west along the south line of said SE 1/4 of the NE 1/4 to the point of beginning, being a part of the SE 1/4 of NE 1/4 and SW 1/4 of NE 1/4 of Sec. 16, T 17 S, R 1 E, St. Clair County, Alabama.

A L S O

Part of the NE 1/4 of the SE 1/4 of Sec. 16, T 17 S, R 1 E, situated in Jefferson County, Alabama, more particularly described as follows:

Begin at the NW corner of said 1/4-1/4 section, run thence eastwardly along the north line of said 1/4-1/4 section to the center line of Cahaba Creek; run thence southwestwardly along the center line of said Cahaba Creek to a point which lies south 47° 56' East, 310.86 feet from the NW corner of said 1/4-1/4 section; run thence North 47° 56' West for a distance of 310.86 feet to the point of beginning.

TO HAVE AND TO HOLD to the said GRANTEES for and during their joint lives and upon the death of either of them, then to the survivor of them in fee simple, and to the heirs and assigns of such survivor forever, together with every contingent remainder and right of reversion.

And I (we) do for myself (ourselves) and for my (our) heirs, executors, and administrators covenant with the said GRANTEES, their heirs and assigns, that I am (we are) lawfully seized in fee simple of said premises; that they are free from all encumbrances, unless otherwise noted above; that I (we) have a good right to sell and convey the same as aforesaid; that I (we) will and my (our) heirs, executors and administrators shall warrant and defend the same to the said GRANTEES, their heirs and assigns forever, against the lawful claims of all persons.

IN WITNESS WHEREOF, we have hereunto set our hand(s) and seal(s), this 29th day of July, 1968.

WITNESS: Gordon L. Figgles (Seal), Charles Murray (Seal), J. Bernard Owen, Jr. (Seal)

Edwin G. Goss (Seal), Jo Ann M. Goss (Seal)

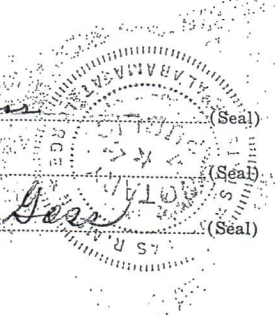

STATE OF ALABAMA } MADISON COUNTY }

General Acknowledgment

I, the undersigned authority, a Notary Public in and for said County, in said State, hereby certify that Edwin G. Goss and wife, Jo Ann M. Goss whose name s. are signed to the foregoing conveyance, and who are known to me, acknowledged before me on this day, that, being informed of the contents of the conveyance they executed the same voluntarily on the day the same bears date.

Given under my hand and official seal this 29th day of July, A. D., 1968. Dallas K. Moor, Notary Public. My Commission Expires Nov. 30, 1970

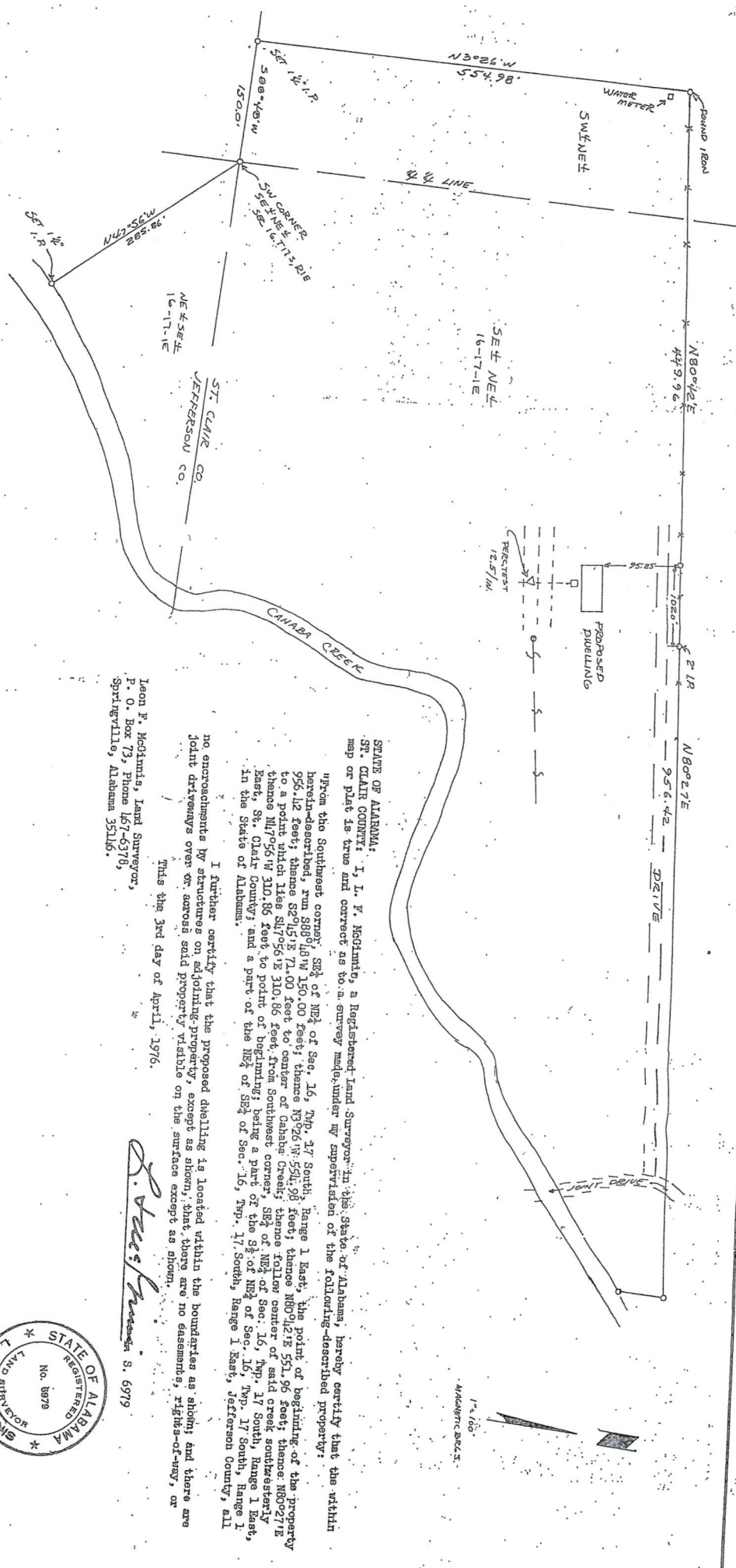

**STATE OF ALABAMA:**

SPR. CLAIM COUNTY: I, I. F. McGinnis, a Registered Land Surveyor in the State of Alabama, hereby certify that the within map or plat is true and correct as to a survey made under my supervision of the following described property:

Upon the Southwest corner, S½ of NE¼ of Sec. 16, Twp. 17 South, Range 1 East, the point of beginning of the property herein-described, run S88°40'W 150.00 feet; thence N9°26'W 551.98 feet; thence N80°22'E 71.00 feet to center of Canaba Creek; thence follow center of said creek southeasterly to a point which lies S47°05'W 310.86 feet, from Southwest corner, S½ of NE¼ of Sec. 16, Twp. 17 South, Range 1 East, thence N47°05'W 310.86 feet to point of beginning; being a part of the ½ of NE¼ of Sec. 16, Twp. 17 South, Range 1 East, St. Clair County; and a part of the NE¼ of Sec. 16, Twp. 17 South, Range 1 East, Jefferson County, all in the State of Alabama.

I further certify that the proposed dwelling is located within the boundaries as shown; and there are no encroachments by structures on adjoining property, except as shown; that there are no easements, rights-of-way, or joint driveways over or across said property visible on the surface except as shown.

This the 3rd day of April, 1976.

Leon F. McGinnis, Land Surveyor,  
P. O. Box 73, Phone 457-6376,  
Springville, Alabama 35116.

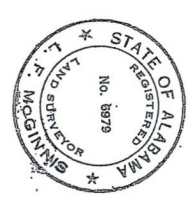

## LEGAL DESCRIPTION

Parcels of land situated in and being part of the SE 1/4 of the NE 1/4 and a part of the SW 1/4 of the NE 1/4 of Section 16, Township 17 South, Range 1 East, St Clair County, Alabama, Pell City Division and being more particularly described as follows:

## TRACT 1: Parcel #26-05-16-1-001-029.000

Commence at a 2" crimped pipe locally excepted as the NE corner of Section 16, Township 17 South, Range 1 East and run South 02° 44' 02" East a distance of 1415.44 feet; thence South 88° 38' 20" West a distance of 448.83 feet; thence South 88° 39' 46" West a distance of 605.32 feet to the Point of Beginning of the following tract of land; thence South 88° 42' 47" West a distance of 36.99 feet thence South 76° 06' 02" West a distance of 177.59 feet; thence North 13° 53' 58" West a distance of 451.05 feet; thence South 64° 23' 13" West a distance of 153.13 feet; thence South 02° 34' 24" East a distance of 1006.87 feet; thence North 79° 44' 13" East a distance of 12.00 feet; thence North 30° 33' 13" East a distance of 784.49 feet to the point of beginning.

## TRACT 2: Parcel #26-05-16-1-001-037.000

Commence at a 2" crimped pipe locally excepted as the NE corner of Section 16, Township 17 South, Range 1 East and run South 02° 44' 02" East a distance of 1415.44 feet to the Point of Beginning of the following tract of land; thence South 88° 38' 20" West a distance of 448.83 feet; thence South 88° 39' 46" West a distance of 605.32 feet; thence South 30° 33' 13" West a distance of 784.49 feet to a 2 inch open pipe found; thence North 81° 01' 13" East a distance of 339.47 feet; thence North 80° 56' 13" East a distance of 199.58 feet; thence North 80° 45' 13" East a distance of 300.80 feet; thence North 80° 43' 13" East a distance of 226.00 feet; thence North 80° 34' 13" East a distance of 213.31 feet; thence North 80° 58' 13" East a distance of 214.64 feet; thence North 02° 44' 02" West a distance of 463.04 feet to the point of beginning.

LESS AND EXCEPT that parcel acquired by Jones Street, LLC by quitclaim deed from Larry Alan Johnson filed on 3-24-03, in Deed Book 2003, page 2509 in the Probate Office of St. Clair County, Alabama. The grantor therein only had a tax interest as acquired by virtue of prior tax sale and tax deed dated 5-14-84 and attached to and made a part of the instrument referenced hereinabove. Said parcel being more particularly described as follows:

Commence at the NE corner of Section 16; thence run West 20 feet; thence run South 1450 feet to the point of beginning, thence West 110' x 50' X 100' x 50' to the point of beginning.

Said parcel also being referred to as Tax Parcel No. 59-26-05-16-0.001-038.

## TRACT 3:

## Parcel I: Parcel #26-05-16-1-001-040.000

Commence at a 2" crimped pipe locally excepted as the NE corner of Section 16, Township 17 South, Range 1 East and run South 02° 44' 02" East a distance of 1949.17 feet to the Point of Beginning of the following tract of land; thence South 02° 44' 02" East a distance of 682.87 feet; thence South 54° 20' 00" West a distance of 14.65 feet; thence North 35° 40' 00" West a distance of 167.00 feet thence North 54° 20' 00" East a distance of 21.00 feet; thence North 27° 24' 11" West a distance of 62.60 feet thence South 54° 20' 00" West a distance of 130.00 feet; thence North 35° 40' 00" West a distance of 324.04 feet to the centerline of Little Cahaba Creek; thence along the centerline of said creek the

following: North  $04^{\circ} 02' 22''$  East a distance of 92.52 feet; thence North  $58^{\circ} 25' 10''$  East a distance of 42.15 feet; thence North  $80^{\circ} 15' 27''$  East a distance of 59.79 feet; thence South  $86^{\circ} 23' 24''$  East a distance of 87.64 feet; thence North  $62^{\circ} 43' 30''$  East a distance of 32.11 feet; thence North  $38^{\circ} 04' 35''$  East a distance of 80.62 feet; thence North  $44^{\circ} 20' 46''$  East a distance of 117.11 feet; thence North  $61^{\circ} 08' 20''$  East a distance of 38.92 feet to the point of beginning.

LESS AND EXCEPT existing right of way of Jones Road (20' ROW).

PARCEL II: Parcel#26-05-16-1-001-037.000

That parcel acquired by Jones Street, LLC by quit claim deed from Larry Alan Johnson filed on 3-24-03, in Deed Book 2003, page 2509 in the Probate Office of St. Clair County, Alabama. The grantor therein only had a tax interest as acquired by virtue of prior tax sale and tax deed dated 5-14-84 and attached to and made a part of the instrument referenced hereinabove. Said parcel being more particularly described as follows:

Commence at the NE corner of Section 16, Township 17 South, Range 1 East, St. Clair County, Alabama, thence run West 20 feet thence run South 1450 feet to the point of beginning, thence West  $110' \times 50' \times 100' \times 50'$  to the point of beginning.

Said parcel also being referred to as Tax Parcel No. 59-26-05-16-0.001-038.

131042-42

671

2013 3039  
Recorded in the Above  
DEED Book & Page  
03-26-2013 08:52:03 AM  
Mike Bowling - Judge of Probate  
St. Clair County, Alabama

**AFTER RECORDING,  
RETURN TO:**

John A. Myrick  
1730 Jones St  
Leeds, AL 35094

[space above reserved for recorder's use only]

**THIS DOCUMENT  
PREPARED BY:**

Hunton & Williams LLP  
1445 Ross Avenue, Suite 3700  
Dallas, Texas 75202  
Attn: Adam B. Fritcher

**SEND TAX NOTICE TO:**

John A. Myrick  
1730 Jones St  
Leeds, AL 35094

who makes no representation as to  
status of title or to matters which  
would be disclosed by a current  
survey

**SPECIAL WARRANTY DEED**

STATE OF ALABAMA           §  
  §  
COUNTY OF ST. CLAIR   §

KNOW ALL MEN BY THESE PRESENTS:

**KNOW ALL MEN BY THESE PRESENTS**, that for and in consideration of the sum of TEN AND NO/100 Dollars (\$10.00) and other good and valuable consideration to the undersigned Grantor paid by the Grantee herein, the receipt whereof is acknowledged, the said **LPP MORTGAGE LTD.**, a Texas limited partnership, whose mailing address is: c/o CLMG Corp., 7195 Dallas Parkway, Plano, Texas 75024 ("**Grantor**"), DOES GRANT, BARGAIN, SELL AND CONVEY unto **MICHAEL G. MYRICK, JOHN A. MYRICK and JANIE P. MYRICK**, as joint tenants with rights of survivorship (collectively, the "**Grantee**"), having an address of 539 Woodruff Parkway, Leeds, Alabama 35094, the real property situated in the County of St. Clair, State of Alabama, and more particularly described on Exhibit A attached hereto and made a part hereof for all purposes, together with all of Grantor's right, title and interest, if any, in and to all easements benefiting such real property (collectively, the "**Property**").

This Special Warranty Deed is made and accepted expressly subject to any and all matters of record, and any easements, exceptions, restrictions, rights of redemption and other encumbrances and any

and all matters that would be shown by a visual inspection and/or accurate survey of the Property, including, without limitation, the matters set forth in Exhibit B attached hereto and made a part hereof for all purposes (the "**Permitted Exceptions**").

TO HAVE AND TO HOLD the Property, subject to the Permitted Exceptions, unto Grantee, its successors and assigns forever; and Grantor does hereby bind itself, its successors and assigns to WARRANT AND FOREVER DEFEND all and singular the Property unto Grantee and its successors and assigns, against any person whomsoever lawfully claiming or to claim the same or any part thereof by, through or under Grantor, but not otherwise, subject to the Permitted Exceptions.

[SIGNATURE PAGE FOLLOWS]

IN WITNESS WHEREOF, Grantor has executed this Special Warranty Deed to be effective as of the 21<sup>st</sup> day of March, 2013.

**GRANTOR:**

**LPP MORTGAGE LTD.,**  
a Texas limited partnership

By: Property Acceptance Corp.,  
a Texas corporation,  
its general partner

By: *Michael D. Wyant*  
Name: **Michael D. Wyant**  
Its: **Its Authorized Signatory**

STATE OF TEXAS

§  
§  
§

COUNTY OF COLLIN

I, the undersigned authority, a Notary Public, in and for said county in said state, hereby certify that *Michael D. Wyant*, the Authorized Signatory of Property Acceptance Corp., a Texas corporation, the general partner of LPP MORTGAGE LTD., a Texas limited partnership, and whose name is signed to the foregoing instrument, and who is known to me, acknowledged before me on this day that, being informed of the contents of said instrument, he, as such Authorized Signatory and with full authority, executed the same voluntarily for and as the act of said corporation and said limited partnership.

Given under my hand and official seal this 18 day of March, 2013.

(Seal)



*Cindy Lewis*  
Notary Public for the State of Texas  
(signature of Notary Public)

My Commission Expires: *Sept. 22, 2013*

**Item Attachment Documents:**

2. Consider Determination of Certain Conditions to be an Annoyance and Public Nuisance in Violation of Chapter 32 of the Code of Ordinances at 1042 Brian Drive



**PUBLIC**

**NUSIANCE**

**1042 BRIAN DR**

**2500202001027000**

**CITY OF LEEDS  
RESOLUTION 19-001868**

**RESOLUTION IN DETERMINATION OF CERTAIN CONDITIONS TO BE AN ANNOYANCE AND PUBLIC NUISANCE IN VIOLATION OF CHAPTER 32 OF THE CODE OF ORDINANCES, FOR THE CITY OF LEEDS, AL.**

**WHEREAS**, in accordance with, without limitation, Code of Ordinances for the city of Leeds, Alabama Chapter 32, §11-47-117, and 11-67-60 to 11-67-67 Code of Alabama 1975 (cumulatively referred to as the "Law"), the City Council of the City of Leeds has the authority to determine that certain conditions upon certain properties in the city of Leeds are offensive, produce an annoyance, constitute a threat to the general public health, safety and welfare of the City of Leeds, Alabama and are in fact a public nuisance; and

**WHEREAS**, employees or agents of the City of Leeds have identified certain conditions to be a nuisance in violation of the law as existing on the certain property at 1042 BRIAN DR LEEDS, AL 35094, Parcel ID: 2500202001027000 which is identified in Exhibit A attached hereto and incorporated herein (the "Property"); and

**WHEREAS**, in accordance with the Law, the City Council of the City of Leeds, after considering the report and the associated notices as presented by staff, may find that the subject conditions identified by the supporting information and documentation related to the subject property(ies) are a public nuisance and order the immediate abatement of such conditions; and

**WHEREAS**, the City Council of the City of Leeds may hold a public hearing if requested by the property owner to have the opportunity of being heard and to discuss the conditions as presented; and

**WHEREAS**, in accordance with the Law, the City of Leeds is to keep an account of the cost of abating or removing the nuisance on any such property when the owner fails to comply with the provided notices; and

**WHEREAS**, in accordance with the Law, the City Council of the City of Leeds desires to make a determination as to whether or not a public nuisance actually exists at the subject property(ies), based on the information as presented, and potentially order the abatement of any such nuisance(s).

**NOW THEREFORE, BE IT RESOLVED**, by the City Council of the City of Leeds follows:

1. All of the Recitals above are true and correct and are hereby incorporated herein as if fully set forth
2. The conditions identified by the Notice(s) of the Public Nuisance, in relation to the Property(ies) identified on the report as Attached hereto as Exhibit A including the requisite notices and supporting information as provided to the Property owner and posted at the Property, and all hereby declared to be a public nuisance in the City of Leeds.
3. The identified public nuisance(s) is related to the subject property(ies) shall be abated and/or removed by the City, if necessary, with costs assessed to the Subject Property.
4. City staff is to create a report of the related costs for abating or removing any remaining nuisance(s) from the Property and to provide such report back to the City Council for approval of the costs related to the same.
5. The provisions of the Resolution are severable. If any part of the Resolution is determined to be invalid, unenforceable or unconstitutional, such determination shall not affect any other part of this Resolution.
6. The City Budget is amended to fund the deceleration of public Nuisance abatements.

**ADOPTED and APPROVED** this the 01/06/2020  
CITY OF LEEDS, ALABAMA

\_\_\_\_\_  
DAVID MILLER, MAYOR

\_\_\_\_\_  
DATE

ATTEST:

AYES \_\_\_\_\_

NAYS \_\_\_\_\_

ABSENT FROM  
VOTING \_\_\_\_\_

ABSTAIN \_\_\_\_\_

\_\_\_\_\_  
Toushi Arbitelle,  
CITY CLERK

I, Toushi Arbitelle, City Clerk of the City of Leeds, hereby certify that the above Resolution was duly adopted by the City Council of the City of Leeds at a regular meeting held on 01/06/2020.

\_\_\_\_\_  
Toushi Arbitelle, City Clerk

# City of Leeds, Alabama

Department of Development Services  
1404 9th St. Leeds, AL 35094  
205-699-2585 development@leedsalabama.gov

TRUITT JONATHAN E  
1042 BRIAN DR  
LEEDS, AL 35094

Reference: 19-001868  
Parcel ID: 2500202001027000

## **NOTICE AND ORDER TO ABATE**

**NOTICE IS HEREBY GIVEN THAT** TRUITT JONATHAN E is in violation of Chapter 32 of the City of Leeds, Municipal Code. The violation has been investigated, declared a public nuisance by the City Enforcement Officer and must be abated immediately.

The public nuisance is on property located at: 1042 BRIAN DR LEEDS, AL 35094

**YOU ARE HEREBY ORDERED TO ABATE SAID PUBLIC NUISANCE within ten (10) days** consecutive calendar days from the issuance of this Order. The issuance date is specified below. You may abate the nuisance by REMOVE ITEMS IN VIOLATION OF ORD. 2016-02-04

Section: Sec 32-44  
Description: Illegal Deposits  
Corrective Action: Cease Activity/Remove Offending Material 72 Hrs  
Comments:

Section: Sec 32-76-c  
Description: Inoperable/Unlicensed Vehicle  
Corrective Action: Remove Offending Vehicles 10 Days  
Comments:

If you fail to abate the public nuisance within ten (10) days, the City may order its abatement by public employees, private contractor, or other means, and the cost of said abatement may be levied and assessed against the property as a special assessment lien or billed directly to the property owner.

This Matter will be heard at a hearing before the City Council on 01/06/2020 at the City Civic Center located at 1000 Park Drive, Leeds, Alabama. The decision of the City Council on this Matter will be final and conclusive.

**YOU HAVE THE RIGHT TO BE HEARD** at the hearing identified above. You have the right to:

1. Be present at the hearing and to present your evidence against this Order in writing prior to the hearing;
2. Provide your written statement against the Order and to specify the reasons not to enforce the Order, containing your name, address and telephone number,
3. Submit your written statement & request to be heard to the following address within at least 24 hours prior to the subject hearing: **1404 9th St, Leeds, Alabama. (205) 699-2585**

In the event that the hearing results in confirmation of a public nuisance, the City will take the necessary steps to abate the nuisance and assess all costs against the subject property. The City also reserves the right to forward the matter to the Municipal Court for further enforcement actions pursuant to Chapter 32 of the City Code.

If you have any questions regarding this matter, you may direct them to the City Enforcement Officer issuing this Notice at the address or telephone number listed above.

Signed: \_\_\_\_\_  
Enforcement Officer

ISSUANCE DATE: December 06, 2019



Document: 4

**Date Taken:**12/06/2019  
**Address:**1042 BRIAN DR

**Taken by:**Brad Watson  
**Case Number:**19-001868



Document: 3

**Date Taken:**12/06/2019  
**Address:**1042 BRIAN DR

**Taken by:**Brad Watson  
**Case Number:**19-001868



Document: 2

**Date Taken:**12/06/2019  
**Address:**1042 BRIAN DR

**Taken by:**Brad Watson  
**Case Number:**19-001868



Document: 1

**Date Taken:**12/06/2019  
**Address:**1042 BRIAN DR

**Taken by:**Brad Watson  
**Case Number:**19-001868



Document: 1

**Date Taken:**12/06/2019  
**Address:**1042 BRIAN DR

**Taken by:**Brad Watson  
**Case Number:**19-001868



**Item Attachment Documents:**

3. Consider Tax Abatement Agreement with Hubbell Power Systems Inc at 1612 Moores Street



ALABAMA DEPARTMENT OF REVENUE
Application to Granting Authority
for Abatement of Taxes

Form CO: CAA
6/15

Under Chapter 9B, Title 40, Code of Alabama 1975

Noneducational Sales and Use Taxes, Noneducational Property Taxes, and/or Mortgage and Recording Taxes

This form is to be submitted to the granting authority for consideration in granting an abatement of all state and local noneducational property taxes, all construction related transaction (sales and use) taxes, except those local construction related transaction taxes levied for educational purposes or for capital improvements for education, and/or mortgage and recording fees, in accordance with the provisions of Section 40-9B-1 et seq., Code of Alabama 1975.

1a. TYPE OF ABATEMENT APPLYING FOR:
[X] Sales & Use Taxes [X] Property Taxes [ ] Mortgage & Recording Taxes
2. PROJECT NAICS CODE: 3 3 3 6 1 3

1b. IS APPLICANT REQUESTING PROPERTY TAX ABATEMENT FOR A PERIOD LONGER THAN 10 YEARS?
[ ] Yes [X] No
3. TYPE OF PROJECT:
[ ] New Project [X] Major Addition To An Existing Facility

4. DOES MAJOR ADDITION EQUAL THE LESSER OF: (CHECK APPLICABLE BOX)
[ ] \$2,000,000 - OR - [ ] 30% of original cost of existing property, original cost \$

5. PROJECT APPLICANT: Hubbell Power Systems, Inc.
DBA: Hubbell Power Systems, Inc.

6. ADDRESS OF APPLICANT: 40 Waterview Drive
CITY: Shelton STATE: CT ZIP CODE: 06484

7. NAME OF CONTACT PERSON: Ben Gossart
EMAIL ADDRESS: bgossart@hubbell.com
TELEPHONE NUMBER: ( 475 ) 882-4277

8. DATE COMPANY ORGANIZED: 3/18/1994

9. PHYSICAL LOCATION OF PROJECT: 1612 Moores Street

CITY (IF OUTSIDE CITY LIMITS, PLEASE INDICATE): Leeds
COUNTY: Jefferson ZIP CODE: 35094

10. BRIEF DESCRIPTION OF PROJECT (ATTACH A COMPLETE AND DETAILED LISTING OF PROJECT PROPERTY COSTS TO ENABLE A COST/BENEFIT ANALYSIS BY GRANTING AUTHORITY):
See attached for detailed project description

11. ESTIMATED DATE CONSTRUCTION WILL BEGIN: August 2019
12. ESTIMATED DATE CONSTRUCTION WILL BE COMPLETED: July 2022
13. ESTIMATED DATE PROPERTY WILL BE PLACED IN SERVICE: Various

14. HAVE BONDS BEEN ISSUED FOR PROJECT: [ ] No [ ] Yes If yes, date bonds issued:
15. WILL BONDS BE ISSUED FOR PROJECT: [X] No [ ] Yes If yes, projected date of issue:

Table with 5 columns: 16. ESTIMATED NUMBER OF NEW EMPLOYEES, 17. ESTIMATED ANNUAL PAYROLL OF NEW EMPLOYEES, Estimated Investment for Project, 18. COST OR VALUE FOR PROPERTY TAX, 19. COST SUBJECT TO SALES TAX. Rows include Land, Existing Building(s), Existing Personal Property, New Building(s) and/or New Additions to Existing Building(s), New Manufacturing Machinery, and Other New Personal Property.

The abatement of noneducational property taxes is based on the market value of specific assets; therefore, the actual amount of taxes abated is determined each year as the property is assessed and valued. An abatement of noneducational sales and use taxes shall apply only to tangible personal property and taxable services incorporated into private use industrial property, the cost of which may be added to capital account with respect to the property, determined without regard to any rule which permits expenditures properly chargeable to capital account to be treated as current expenses.

I hereby affirm that, to the best of my knowledge and belief, the information in this application and any accompanying statement, schedules, and other information is true, correct and complete.

Anne Boyd
NAME (PRINT)

SIGNATURE

Vice President & Assistant Treasurer

TITLE

DATE

## Instructions for Preparing Application to Granting Authority for Abatement of Taxes (Form CO: CAA)

Under Chapter 9B of Title 40, *Code of Alabama 1975*

### GENERAL INSTRUCTIONS

Chapter 9B, Title 40, *Code of Alabama 1975*, provides for an abatement of all state and local noneducational property taxes, all construction related transaction taxes (sales and use taxes), except those local construction related transaction taxes levied for educational purposes or for capital improvements for education, and/or all mortgage and recording taxes relating to mortgages, deeds, and documents used to issue or secure obligations and convey title into or out of the name of a public authority, county or municipal government.

This form is to be submitted to the granting authority for consideration in granting an abatement of noneducational sales and use taxes, noneducational property taxes, and/or mortgage and recording taxes. **If you have any questions about this form or the abatement of taxes in general, please contact the Alabama Department of Revenue at (334) 242-1175.**

**A complete and detailed listing of project costs should be attached to this application in order for the granting authority to make a cost/benefit analysis in accordance with Section 40-9B-6(a).**

### STATUTORY REQUIREMENTS FOR ABATEMENTS

The following are qualifying business activities under Section 40-9B-3, *Code of Alabama 1975*:

- Industrial or Research Enterprise – Any trade or business in the 2007 North American Industrial Classification System (NAICS), promulgated by the Executive Office of the President of the United States, Office of Management and Budget as: Sectors 31 (except National Industry 311811), 32, 33, 55 (if not for the production of electricity), Subsectors 423, 424, 482, 493, 511, 517, 518, 927, Industry Groups 1133, 2121, 4862, 4882, 4883 (other than 48833) 5121 (other than 51213), 5415, 5417, Industries 22111, 48691, 48699, 48819, 51221, 51913, 52232, 54133, 54134, 54138, 56291, 56292, 92811, National Industries 115111, 221330, 541614, 561422 (in bound call centers only), 562213, and 611512.
- Subsector 493, Industry Number 488310, or 488320 when such trade or business is conducted on premises in which the Alabama State Port Authority has an ownership, leasehold, or other possessory interest and such premises are used as part of the operations of the Alabama State Port Authority. These projects require written approval of the Governor, Finance Director, and the Director of the Alabama State Port Authority.
- Headquarters Facility – Any trade or business in the 2007 North American Industrial Classification System (NAICS), promulgated by the Executive Office of the President of the United States, Office of Management and Budget as National Industry 551114 at which at least 50 new jobs are located.
- Data Processing Center – An establishment, at which at least 20 new jobs are located, engaged in the provision of complete processing and specialized reports from data, the provision of automated data processing and data entry services, the provision of an infrastructure for hosting or data processing services, the provision of specialized hosting activities, the provision of application service provisioning, the provision of general time-share mainframe facilities, or some combination of the foregoing, without regard to whether any other activities are conducted at the establishment.
- Research & Development Facility – An establishment engaged in conducting original investigations undertaken on a systematic basis to gain new knowledge and/or applying research findings or other scientific knowledge to create new or significantly improved products or processes.
- Renewable Energy Facility – Any plant, property, or facility that either:
  1. Produces electricity or natural gas, in whole or in part, from biofuels as such term is defined in Section 2-2-90(c)(2) or from renewable energy resources as such term is defined in Section 40-18-1(30) with the exception that hydropower production shall be excluded from such definition; or
  2. Produces biofuel as such term is defined in Section 2-2-90(c)(2).
- Alternative Energy Resources Electricity Production Project - A project owned by a utility described in Section 37-4-1(7)a, Code of Alabama 1975, or owned by a company which is itself owned by a utility, at which the predominant trade or business activity conducted will be the production of electricity from alternative energy resources (coal gasification or liquefaction, nuclear and/or advanced fossil-based generation), the capital costs of which are not less than \$100,000,000.
- Hydropower Electricity Production Project - A project owned by a utility described in Section 37-4-1(7)a, or owned by a company which is itself owned by a utility, at which the predominant trade or business activity conducted will be the production of electricity from hydropower production as defined in Section 40-18-1(16), the capital costs of which are not less than \$5,000,000.
- Tourist Destination Attractions – A commercial enterprise which is open to the public not less than 120 days during a calendar year and is designed to attract visitors from inside or outside of the State of Alabama, typically for its inherent cultural value, historical significance, natural or man-made beauty, or entertainment or amusement opportunities. The term shall include, but not be limited to, a cultural or historical site; a botanical garden; a museum; a wildlife park or aquarium open to the public that cares for and displays a collection of animals or fish; an amusement park; a convention hotel and conference center; a water park; or a spectator venue or arena.
- Any of the 11 targeted business sectors under the Accelerate Alabama Strategic Economic Development Plan adopted in January 2012 by the Alabama Economic Development Alliance, created by Executive Order Number 21 of the Governor on July 18, 2011, which include Advanced Manufacturing in Aerospace/Defense, Automotive, Agricultural Products/Food Production, Steel/Metal, Forestry Products and Chemicals; Technology in Biosciences, Information Technology, Enabling Technologies; Distribution/Logistics and Corporate Operations.

## LINE BY LINE INSTRUCTIONS

**Item 1a.** Indicate the type(s) of abatement(s) being requested.

**Sales and Use Taxes** – Chapter 9B, Title 40, *Code of Alabama 1975*, provides for the abatement of certain noneducational sales and use taxes imposed by Chapter 23 of Title 40, *Code of Alabama 1975*. The abatement applies to the tangible personal property and taxable services incorporated into the project, the cost of which may be added to the capital account with respect to the project. However, only the state and local noneducational sales and use taxes may be abated. No sales and use tax abatement shall extend beyond the date the project is placed in service.

**Property Taxes** – Chapter 9B, Title 40, *Code of Alabama 1975*, provides for the abatement of noneducational property taxes imposed by the state, counties, municipalities and other taxing jurisdictions in Alabama. Only industrial property not previously placed in service in Alabama by the user or a related party may be eligible for an abatement of noneducational property taxes.

**Mortgage And Recording Taxes** – Chapter 9B, Title 40, *Code of Alabama 1975*, provides for the abatement of all taxes imposed by Chapter 22 of Title 40 of the *Code of Alabama 1975*, relating to mortgages, deeds, and documents used to issue or secure obligations and convey title into or out of the name of a public authority.

**Item 1b.** Indicate if applicant is requesting abatement of property taxes for a period longer than 10 years. For any property tax abatement that is granted for over 10 years, the noneducational municipal taxes can only be abated by the City Government, noneducational county taxes can only be abated by the County Government, and state taxes can only be abated by the Governor. The governing body of the municipality and county can authorize a public industrial authority to provide by resolution for such consent on its behalf.

**Item 2.** If the predominant business activity is a headquarters facility, an industrial or research enterprise as defined in *Code of Alabama 1975* Section 40-9B-3(10)(a) or a state docks project as defined in Section 40-9B-3(10)(b), enter the 2007 North American Industrial Classification System (NAICS) code for the project.

**Item 3.** Indicate if project is a new project or a major addition.

**New Project** – Any new business in Alabama at which the predominant trade or business activity conducted will constitute an industrial or research enterprise or other qualifying business activity as described above. If new project, skip Item 4.

**Major Addition** – Pursuant to Section 40-9B-3(11), a major addition is an addition to an existing facility in which the addition equals the lesser of thirty (30) percent of the original cost of the existing land, buildings, and equipment (industrial development property), or \$2,000,000, and at which the predominant trade or business activity conducted in Alabama will constitute an industrial or research enterprise or other qualifying business activity as described above. Capitalized repairs, rebuilds, maintenance, replacement equipment, or costs associated with the renovating or remodeling of existing facilities of industrial development property previously placed in service in Alabama by the Company are not eligible for abatement under Chapter 9B.

**Item 4.** Indicate if major addition is in accordance with Section 40-9B-3(11) requirement as denoted above. If major addition does not meet threshold requirement, project is not qualified to receive abatement. Original cost should include the total cost of existing facilities as of the date of application.

**Item 5.** Enter the name of the private user requesting abatement. If project is doing business under another name, also enter the name of the company under "Doing Business As (DBA)."

**Item 6.** Enter the address of the private user requesting abatement.

**Item 7.** Enter the name, email address and telephone number of the person to which all correspondence should be directed regarding the abatement.

**Item 8.** Enter the date the company was organized.

**Item 9.** Enter the physical location of the project. Please include a detailed location, including the City, County and Zip Code.

**Item 10.** Describe the type of business that the project will be engaged in. For projects that do not require a NAICS code, provide a detailed description that will identify the activities as qualifying activities. Attach additional sheets if necessary.

**Item 11.** Enter the estimated date the construction of the project will begin.

**Item 12.** Enter the estimated date the construction of the project will be completed. A data processing center project's completion date will be the maximum exemption period allowed pursuant to Section 40-9B-3(12)b.

**Item 13.** Enter the estimated date the project will be placed in service. If revenue bonds are issued, "placed in service," for property tax purposes, is determined as of the date of the initial issuance of such bonds. Otherwise, with the exception of a data processing center project, "placed in service" for sales and use tax and property tax purposes is determined as the later of 1) the date on which title to the property was acquired by or vested in a county, city, or public authority, or 2) the date on which the property is or becomes owned, for federal income tax purposes, by a private user. A data processing center project's placed in service date will be the maximum exemption period allowed pursuant to Section 40-9B-3(12)b.

**Item 14.** Indicate if bonds have been issued in financing the project. If bonds have been issued, enter the issuance date.

**Item 15.** Indicate if bonds will be issued for financing the project. If bonds will be issued, enter the projected issuance date.

**Column 16.** Enter the estimated number of new employees to be hired at the project. The law requires the number of employees to be employed at the project initially and in each of the succeeding three years.

**Column 17.** Enter the estimated annual payroll for employees at the project. The law requires the estimated payroll of new employees initially and in each of the succeeding three years.

**Column 18.**

**18a.** Enter all costs or value for project land. If land is donated, enter the market value of the land.

**18b.** Enter all costs or value for existing building(s), if any.

**18c.** Enter all costs or value for existing personal property to be incorporated into project. Only personal property not previously placed in service in Alabama by the private user or a related party can be included. If a private user is including existing equipment from outside of Alabama, the existing equipment should be entered here at its original cost.

**18d.** Enter the total cost for new building(s) and/or new additions to existing building(s). Total cost includes building materials, construction costs, engineering costs, etc. Costs associated with renovating or remodeling existing facilities of an operating industrial or research enterprise do not qualify for abatement.

**18e.** Enter the total cost for new manufacturing equipment to be incorporated into the project. Replacement equipment does not qualify for abate-

Under Chapter 9B. New equipment that is defined as upgraded equipment may qualify. Upgraded equipment is equipment that replaces existing equipment, and performs not only the same functions, but also an additional function.

**18f.** Enter the total cost for all other new personal property. Other new personal property may include, but is not limited to, non-manufacturing machinery, office equipment, computers, vehicles, etc. Only personal property that is a depreciable item can be included.

**18g.** Add 18a through 18f and enter total here. This is the total amount on which the initial property taxes will be based. This total must be the total value of the cost or investment in the project. This total must agree with the total investment amount in the abatement resolution and the total investment amount in the abatement agreement.

**Column 19.**

**19d.** Enter the cost of the building materials (subject to sales tax) that become a part of realty for new building(s) and/or new additions to existing building(s). Other building costs (labor, engineering) are not subject to sales tax.

**19e.** Enter the cost of new manufacturing equipment for the project. For sales tax purposes, manufacturing equipment is taxed at a lower rate. Equipment that is purchased used from another company in an isolated transaction is not subject to sales tax and should not be included.

**19f.** Enter the cost of all other new personal property.

**19g.** Add 19d through 19f and enter total here.

**Item Attachment Documents:**

4. Consider Tax Abatement Agreement with Hubbell Power Systems at 8100 Churchill Avenue



# ALABAMA DEPARTMENT OF REVENUE Application to Granting Authority for Abatement of Taxes

Under Chapter 9B, Title 40, Code of Alabama 1975

## Noneducational Sales and Use Taxes, Noneducational Property Taxes, and/or Mortgage and Recording Taxes

This form is to be submitted to the granting authority for consideration in granting an abatement of all state and local noneducational property taxes, all construction related transaction (sales and use) taxes, except those local construction related transaction taxes levied for educational purposes or for capital improvements for education, and/or mortgage and recording fees, in accordance with the provisions of Section 40-9B-1 et seq., Code of Alabama 1975.

1a. TYPE OF ABATEMENT APPLYING FOR: <input checked="" type="checkbox"/> Sales & Use Taxes <input checked="" type="checkbox"/> Property Taxes <input type="checkbox"/> Mortgage & Recording Taxes	2. PROJECT NAICS CODE: <table border="1"><tr><td>3</td><td>3</td><td>3</td><td>6</td><td>1</td><td>3</td></tr></table>	3	3	3	6	1	3
3	3	3	6	1	3		

1b. IS APPLICANT REQUESTING PROPERTY TAX ABATEMENT FOR A PERIOD LONGER THAN 10 YEARS? <input type="checkbox"/> Yes <input checked="" type="checkbox"/> No	3. TYPE OF PROJECT: <input type="checkbox"/> New Project <input checked="" type="checkbox"/> Major Addition To An Existing Facility
--	--

4. DOES MAJOR ADDITION EQUAL THE LESSER OF: (CHECK APPLICABLE BOX)  
 \$2,000,000 - OR -  30% of original cost of existing property, original cost \$ \_\_\_\_\_

5. PROJECT APPLICANT: Hubbell Power Systems, Inc.	DBA: Hubbell Power Systems, Inc.
--	-------------------------------------

6. ADDRESS OF APPLICANT: 40 Waterview Drive	CITY: Shelton	STATE: CT	ZIP CODE: 06484
--	------------------	--------------	--------------------

7. NAME OF CONTACT PERSON: Ben Gossart	EMAIL ADDRESS: bgossart@hubbell.com	TELEPHONE NUMBER: ( 475 ) 882-4277
---	--	---------------------------------------

8. DATE COMPANY ORGANIZED:  
3/18/1994

9. PHYSICAL LOCATION OF PROJECT:  
8100 Churchill Avenue

CITY (IF OUTSIDE CITY LIMITS, PLEASE INDICATE): Leeds	COUNTY: Jefferson	ZIP CODE: 35094
--	----------------------	--------------------

10. BRIEF DESCRIPTION OF PROJECT (ATTACH A COMPLETE AND DETAILED LISTING OF PROJECT PROPERTY COSTS TO ENABLE A COST/BENEFIT ANALYSIS BY GRANTING AUTHORITY):  
See attached for detailed project description

11. ESTIMATED DATE CONSTRUCTION WILL BEGIN: June 2020	12. ESTIMATED DATE CONSTRUCTION WILL BE COMPLETED: May 2023	13. ESTIMATED DATE PROPERTY WILL BE PLACED IN SERVICE: Various
--	--	---

14. HAVE BONDS BEEN ISSUED FOR PROJECT: <input type="checkbox"/> No <input type="checkbox"/> Yes    If yes, date bonds issued:	15. WILL BONDS BE ISSUED FOR PROJECT <input checked="" type="checkbox"/> No <input type="checkbox"/> Yes    If yes, projected date of issue:
---	---

16. ESTIMATED NUMBER OF NEW EMPLOYEES	17. ESTIMATED ANNUAL PAYROLL OF NEW EMPLOYEES	Estimated Investment for Project	18. COST OR VALUE FOR PROPERTY TAX	19. COST SUBJECT TO SALES TAX
INITIALLY	INITIALLY	a. Land (if donated, show market value) .....	18a	XXXXXXXXXXXX
YEAR 1	YEAR 1	b. Existing Building(s) (if any) .....	18b	XXXXXXXXXXXX
5	\$ 255,827		\$ 0	
YEAR 2	YEAR 2	c. Existing Personal Property (if any) .....	18c	XXXXXXXXXXXX
17	\$ 869,811		\$ 2,250,000	
YEAR 3	YEAR 3	d. New Building(s) and/or New Additions to Existing Building(s) (19d = building materials only) .....	18d	19d
18	\$ 920,976			
This form may be used as the application to the granting authority required by Section 40-9B-6(a), Code of Alabama 1975. The information requested here is required by Section 40-9B-6 and Section 40-2-11(7), Code of Alabama 1975.		e. New Manufacturing Machinery .....	18e	19e
		f. Other New Personal Property (non-mfg machinery, office equipment, computers, etc.) .....	18f	19f
		g. TOTALS (PROPERTY TAX TOTAL MUST EQUAL TOTAL PROJECT INVESTMENT. SALES TAX TOTAL WILL BE LESS.) .....	18g	19g
			\$ 2,025,000	\$ 2,025,000
			\$ 0	\$ 0
			\$ 4,275,000	\$ 2,025,000

The abatement of noneducational property taxes is based on the market value of specific assets; therefore, the actual amount of taxes abated is determined each year as the property is assessed and valued. An abatement of noneducational sales and use taxes shall apply only to tangible personal property and taxable services incorporated into private use industrial property, the cost of which may be added to capital account with respect to the property, determined without regard to any rule which permits expenditures properly chargeable to capital account to be treated as current expenses. No abatement of sales and use taxes shall extend beyond the date private use industrial property is placed in service. A verification inspection of qualifying property will be conducted by the Alabama Department of Revenue to insure compliance with Section 40-9B-1 et seq., Code of Alabama 1975, as amended.

I hereby affirm that, to the best of my knowledge and belief, the information in this application and any accompanying statement, schedules, and other information is true, correct and complete.

Anne Boyd  
 \_\_\_\_\_  
 NAME (PRINT)  
  
 \_\_\_\_\_  
 SIGNATURE

Vice President & Assistant Treasurer  
 \_\_\_\_\_  
 TITLE

9/6/19  
 \_\_\_\_\_  
 DATE

## Instructions for Preparing Application to Granting Authority for Abatement of Taxes (Form CO: CAA)

Under Chapter 9B of Title 40, *Code of Alabama 1975*

### GENERAL INSTRUCTIONS

Chapter 9B, Title 40, *Code of Alabama 1975*, provides for an abatement of all state and local noneducational property taxes, all construction related transaction taxes (sales and use taxes), except those local construction related transaction taxes levied for educational purposes or for capital improvements for education, and/or all mortgage and recording taxes relating to mortgages, deeds, and documents used to issue or secure obligations and convey title into or out of the name of a public authority, county or municipal government.

This form is to be submitted to the granting authority for consideration in granting an abatement of noneducational sales and use taxes, noneducational property taxes, and/or mortgage and recording taxes. **If you have any questions about this form or the abatement of taxes in general, please contact the Alabama Department of Revenue at (334) 242-1175.**

**A complete and detailed listing of project costs should be attached to this application in order for the granting authority to make a cost/benefit analysis in accordance with Section 40-9B-6(a).**

### STATUTORY REQUIREMENTS FOR ABATEMENTS

The following are qualifying business activities under Section 40-9B-3, *Code of Alabama 1975*:

- **Industrial or Research Enterprise** – Any trade or business in the 2007 North American Industrial Classification System (NAICS), promulgated by the Executive Office of the President of the United States, Office of Management and Budget as: Sectors 31 (except National Industry 311811), 32, 33, 55 (if not for the production of electricity), Subsectors 423, 424, 482, 493, 511, 517, 518, 927, Industry Groups 1133, 1212, 4862, 4882, 4883 (other than 48833) 5121 (other than 51213), 5415, 5417, Industries 22111, 48691, 48699, 48819, 51221, 51913, 52232, 54133, 54134, 54138, 56291, 56292, 92811, National Industries 115111, 221330, 541614, 561422 (in bound call centers only), 562213, and 611512.
- **Subsector 493, Industry Number 488310, or 488320** when such trade or business is conducted on premises in which the Alabama State Port Authority has an ownership, leasehold, or other possessory interest and such premises are used as part of the operations of the Alabama State Port Authority. These projects require written approval of the Governor, Finance Director, and the Director of the Alabama State Port Authority.
- **Headquarters Facility** – Any trade or business in the 2007 North American Industrial Classification System (NAICS), promulgated by the Executive Office of the President of the United States, Office of Management and Budget as National Industry 551114 at which at least 50 new jobs are located.
- **Data Processing Center** – An establishment, at which at least 20 new jobs are located, engaged in the provision of complete processing and specialized reports from data, the provision of automated data processing and data entry services, the provision of an infrastructure for hosting or data processing services, the provision of specialized hosting activities, the provision of application service provisioning, the provision of general time-share mainframe facilities, or some combination of the foregoing, without regard to whether any other activities are conducted at the establishment.
- **Research & Development Facility** – An establishment engaged in conducting original investigations undertaken on a systematic basis to gain new knowledge and/or applying research findings or other scientific knowledge to create new or significantly improved products or processes.
- **Renewable Energy Facility** – Any plant, property, or facility that either:
  1. Produces electricity or natural gas, in whole or in part, from biofuels as such term is defined in Section 2-2-90(c)(2) or from renewable energy resources as such term is defined in Section 40-18-1(30) with the exception that hydropower production shall be excluded from such definition; or
  2. Produces biofuel as such term is defined in Section 2-2-90(c)(2).
- **Alternative Energy Resources Electricity Production Project** - A project owned by a utility described in Section 37-4-1(7)a, Code of Alabama 1975, or owned by a company which is itself owned by a utility, at which the predominant trade or business activity conducted will be the production of electricity from alternative energy resources (coal gasification or liquefaction, nuclear and/or advanced fossil-based generation), the capital costs of which are not less than \$100,000,000.
- **Hydropower Electricity Production Project** - A project owned by a utility described in Section 37-4-1(7)a, or owned by a company which is itself owned by a utility, at which the predominant trade or business activity conducted will be the production of electricity from hydropower production as defined in Section 40-18-1(16), the capital costs of which are not less than \$5,000,000.
- **Tourist Destination Attractions** – A commercial enterprise which is open to the public not less than 120 days during a calendar year and is designed to attract visitors from inside or outside of the State of Alabama, typically for its inherent cultural value, historical significance, natural or man-made beauty, or entertainment or amusement opportunities. The term shall include, but not be limited to, a cultural or historical site; a botanical garden; a museum; a wildlife park or aquarium open to the public that cares for and displays a collection of animals or fish; an amusement park; a convention hotel and conference center; a water park; or a spectator venue or arena.
- **Any of the 11 targeted business sectors** under the Accelerate Alabama Strategic Economic Development Plan adopted in January 2012 by the Alabama Economic Development Alliance, created by Executive Order Number 21 of the Governor on July 18, 2011, which include Advanced Manufacturing in Aerospace/Defense, Automotive, Agricultural Products/Food Production, Steel/Metal, Forestry Products and Chemicals; Technology in Biosciences, Information Technology, Enabling Technologies; Distribution/Logistics and Corporate Operations.



## LINE BY LINE INSTRUCTIONS

**Item 1a.** Indicate the type(s) of abatement(s) being requested.

**Sales and Use Taxes** – Chapter 9B, Title 40, *Code of Alabama 1975*, provides for the abatement of certain noneducational sales and use taxes imposed by Chapter 23 of Title 40, *Code of Alabama 1975*. The abatement applies to the tangible personal property and taxable services incorporated into the project, the cost of which may be added to the capital account with respect to the project. However, only the state and local noneducational sales and use taxes may be abated. No sales and use tax abatement shall extend beyond the date the project is placed in service.

**Property Taxes** – Chapter 9B, Title 40, *Code of Alabama 1975*, provides for the abatement of noneducational property taxes imposed by the state, counties, municipalities and other taxing jurisdictions in Alabama. Only industrial property not previously placed in service in Alabama by the user or a related party may be eligible for an abatement of noneducational property taxes.

**Mortgage And Recording Taxes** – Chapter 9B, Title 40, *Code of Alabama 1975*, provides for the abatement of all taxes imposed by Chapter 22 of Title 40 of the *Code of Alabama 1975*, relating to mortgages, deeds, and documents used to issue or secure obligations and convey title into or out of the name of a public authority.

**Item 1b.** Indicate if applicant is requesting abatement of property taxes for a period longer than 10 years. For any property tax abatement that is granted for over 10 years, the noneducational municipal taxes can only be abated by the City Government, noneducational county taxes can only be abated by the County Government, and state taxes can only be abated by the Governor. The governing body of the municipality and county can authorize a public industrial authority to provide by resolution for such consent on its behalf.

**Item 2.** If the predominant business activity is a headquarters facility, an industrial or research enterprise as defined in *Code of Alabama 1975* Section 40-9B-3(10)(a) or a state docks project as defined in Section 40-9B-3(10)(b), enter the 2007 North American Industrial Classification System (NAICS) code for the project.

**Item 3.** Indicate if project is a new project or a major addition.

**New Project** – Any new business in Alabama at which the predominant trade or business activity conducted will constitute an industrial or research enterprise or other qualifying business activity as described above. If new project, skip Item 4.

**Major Addition** – Pursuant to Section 40-9B-3(11), a major addition is an addition to an existing facility in which the addition equals the lesser of thirty (30) percent of the original cost of the existing land, buildings, and equipment (industrial development property), or \$2,000,000, and at which the predominant trade or business activity conducted in Alabama will constitute an industrial or research enterprise or other qualifying business activity as described above. Capitalized repairs, rebuilds, maintenance, replacement equipment, or costs associated with the renovating or remodeling of existing facilities of industrial development property previously placed in service in Alabama by the Company are not eligible for abatement under Chapter 9B.

**Item 4.** Indicate if major addition is in accordance with Section 40-9B-3(11) requirement as denoted above. If major addition does not meet threshold requirement, project is not qualified to receive abatement. Original cost should include the total cost of existing facilities as of the date of application.

**Item 5.** Enter the name of the private user requesting abatement. If project is doing business under another name, also enter the name of the company under "Doing Business As (DBA)."

**Item 6.** Enter the address of the private user requesting abatement.

**Item 7.** Enter the name, email address and telephone number of the person to which all correspondence should be directed regarding the abatement.

**Item 8.** Enter the date the company was organized.

**Item 9.** Enter the physical location of the project. Please include a detailed location, including the City, County and Zip Code.

**Item 10.** Describe the type of business that the project will be engaged in. For projects that do not require a NAICS code, provide a detailed description that will identify the activities as qualifying activities. Attach additional sheets if necessary.

**Item 11.** Enter the estimated date the construction of the project will begin.

**Item 12.** Enter the estimated date the construction of the project will be completed. A data processing center project's completion date will be the maximum exemption period allowed pursuant to Section 40-9B-3(12)b.

**Item 13.** Enter the estimated date the project will be placed in service. If revenue bonds are issued, "placed in service," for property tax purposes, is determined as of the date of the initial issuance of such bonds. Otherwise, with the exception of a data processing center project, "placed in service" for sales and use tax and property tax purposes is determined as the later of 1) the date on which title to the property was acquired by or vested in a county, city, or public authority, or 2) the date on which the property is or becomes owned, for federal income tax purposes, by a private user. A data processing center project's placed in service date will be the maximum exemption period allowed pursuant to Section 40-9B-3(12)b.

**Item 14.** Indicate if bonds have been issued in financing the project. If bonds have been issued, enter the issuance date.

**Item 15.** Indicate if bonds will be issued for financing the project. If bonds will be issued, enter the projected issuance date.

**Column 16.** Enter the estimated number of new employees to be hired at the project. The law requires the number of employees to be employed at the project initially and in each of the succeeding three years.

**Column 17.** Enter the estimated annual payroll for employees at the project. The law requires the estimated payroll of new employees initially and in each of the succeeding three years.

**Column 18.**

**18a.** Enter all costs or value for project land. If land is donated, enter the market value of the land.

**18b.** Enter all costs or value for existing building(s), if any.

**18c.** Enter all costs or value for existing personal property to be incorporated into project. Only personal property not previously placed in service in Alabama by the private user or a related party can be included. If a private user is including existing equipment from outside of Alabama, the existing equipment should be entered here at its original cost.

**18d.** Enter the total cost for new building(s) and/or new additions to existing building(s). Total cost includes building materials, construction costs, engineering costs, etc. Costs associated with renovating or remodeling existing facilities of an operating industrial or research enterprise do not qualify for abatement.

**18e.** Enter the total cost for new manufacturing equipment to be incorporated into the project. Replacement equipment does not qualify for abate-

Under Chapter 9B. New equipment that is defined as upgraded equipment may qualify. Upgraded equipment is equipment that replaces existing equipment, and performs not only the same functions, but also an additional function.

**18f.** Enter the total cost for all other new personal property. Other new personal property may include, but is not limited to, non-manufacturing machinery, office equipment, computers, vehicles, etc. Only personal property that is a depreciable item can be included.

**18g.** Add 18a through 18f and enter total here. This is the total amount on which the initial property taxes will be based. This total must be the total value of the cost or investment in the project. This total must agree with the total investment amount in the abatement resolution and the total investment amount in the abatement agreement.

**Column 19.**

**19d.** Enter the cost of the building materials (subject to sales tax) that become a part of realty for new building(s) and/or new additions to existing building(s). Other building costs (labor, engineering) are not subject to sales tax.

**19e.** Enter the cost of new manufacturing equipment for the project. For sales tax purposes, manufacturing equipment is taxed at a lower rate. Equipment that is purchased used from another company in an isolated transaction is not subject to sales tax and should not be included.

**19f.** Enter the cost of all other new personal property.

**19g.** Add 19d through 19f and enter total here.

**Item Attachment Documents:**

5. Minutes from December 02, 2019 Meeting



# CITY OF LEEDS, ALABAMA

## REGULAR COUNCIL MEETING MINUTES

Leeds Civic Center Meeting Room -1000 Park Drive, Leeds, Alabama 35094

December 02, 2019 @ 6:00 PM

---

### CALL COUNCIL MEETING TO ORDER

Mayor David Miller called the meeting to order at 6:05 pm.

### ROLL CALL / INVOCATION / PLEDGE OF ALLEGIANCE

#### PRESENT

Mayor David Miller  
Council member Eric Turner  
Council member Johnny Dutton  
Council member Linda Miller  
Council member Ryan Bell  
Council member Kenneth Washington

#### INVOCATION

Council member Eric Turner

#### PLEDGE OF ALLEGIANCE

Mayor David Miller

### PUBLIC HEARING

1. Amendment 772 Hearing

No one was present. There was no Public Comment, and the matter was referred to Council.

Public Hearing closed at 6:07 pm.

### APPROVE COUNCIL MINUTES

2. Minutes from 11/22/2019 Meeting

Motion to approve November 22, 2019 minutes as presented made by Council member Turner, Seconded by Council member Bell. Voting Yea: Mayor Miller, Council member Turner, Council member Dutton, Council member Miller, Council member Bell, Council member Washington

### REPORTS OF STANDING COMMITTEES OR SPECIAL BOARDS:

3. Finance Committee Report - Linda Miller

No Report.

4. Public Safety Committee Report - Kenneth Washington  
No Report.
5. Public Works Committee Report- Ryan Bell  
Council member Bell introduced two (2) seniors working on their Senior project for school. They plan to clean up the small playground area and small ball fields located adjacent to tennis courts. Also, Council member Bell recognized Zoning Administrator Watson and Public Works Director Warren for their fast response to an issue.

#### **REPORTS OF OFFICERS:**

6. Mayor's Report - Mayor David Miller  
Stated that Buc-ee's has an estimated opening in 11-12 months.
7. Police Department - Chief Atkinson  
No Report.
8. Fire Department - Chief Parsons  
No Report.
9. Library - Director Carden  
Today was a busy day as it was the first day working with Grant Program at Leeds City Schools.
10. Municipal Court - Magistrate Roberts  
No Report.
11. Development Services - Zoning Administrator Watson  
Reported that the Personnel Board of Jefferson County has allowed the City to hire four (4) interns from the High School starting next year. The School will make the recommendations.
12. Public Works Department - Public Works Director Warren  
Reported that our bucket truck will be here next week. Over time, this will be a great savings to the City.

#### **OLD BUSINESS:**

There was no Old Business for discussion.

#### **NEW BUSINESS:**

13. Resolution 19-001051 Confirming Report of Costs and Creating Weed Lien on 0 Clairmont Drive  
Motion made by Council member Bell, Seconded by Council member Dutton.  
Voting Yea: Mayor Miller, Council member Turner, Council member Dutton, Council member Miller, Council member Bell, Council member Washington
14. Resolution 2019-12-01 Consider Use and Granting of Public Funds and Things of Value in Aid to a Private Entity Pursuant to Amendment 772 of the Alabama Constitution (Budgeted)  
Motion made by Council member Turner, Seconded by Council member Bell.  
Voting Yea: Mayor Miller, Council member Turner, Council member Dutton, Council member Miller, Council member Bell, Council member Washington

**PUBLIC COMMENTS**

Josh Sigler (works for United Way) made presentation to Council looking for support.

**ADJOURNMENT**

Motion to adjourn made by Council member Turner, Seconded by Council member Miller.  
Voting Yea: Mayor Miller, Council member Turner, Council member Dutton, Council member Miller,  
Council member Bell, Council member Washington

The meeting was adjourned at 6:25 pm.

---

David Miller, Mayor

ATTEST:

---

Toushi Arbitelle, City Clerk

**Item Attachment Documents:**

10. Police Department: Chief Atkinson



J ATKINSON  
CHIEF OF POLICE

THE CITY OF LEEDS  
LEEDS POLICE DEPARTMENT

1040 PARK DRIVE  
LEEDS, ALABAMA 35094-2213  
BUS: (205) 699-2581  
FAX: (205) 702-6556



DAVID MILLER  
MAYOR

DATE: December 10, 2019

Mayor and Council:

The following is a summary of the Police Department activities for the month of November and the 2019 year-to-date totals.

**Police Department Activity Summary**

Category	*Calls Answered	Accidents Investigated	All Reports	Traffic Stops	Traffic Citations	Warning Citations	Non-Traffic Citations	Misd. Arrests	Felony Arrests	Warrants Served
Nov 2019	785	42	199	275	202	109	2	27	5	55
2019 YTD	8646	418	2058	3192	2567	1367	53	295	103	763
Nov 2018	635	62	174	240	144	122	0	19	3	41
2018 YTD	9343	417	2219	2303	1540	1108	36	248	81	598
Category	*Officer Assists	*Public Assists	Court Hours	Training Hours	Shifts Worked	Miles Driven	Dispatch CFS	Business Cks/Card		
Nov 2019	326	287	41	16	223	17,060	1596	199		
2019 YTD	3639	3168	374	358	2617	198,982	17758	2579		
Nov 2018	341	263	18	78	247	17,079	1520			
2018 YTD	3392	3687	298	521	2430	161,366	18637			

\*Calls answered, Officer Assists and Public Assists equal all calls.

**Jail Expenses**

**Prisoner Transportation**

No. of Inmate Days	117	Nov 2019	Miles =	1,374.6	Nov 2019	Hours =	47.0
Nov Expenses	\$3,802.50	2019 YTD	Miles =	16,876.5	2019 YTD	Hours =	601.0
2019 YTD	\$69,127.50						
2018 Total	\$71,490.00	2018 Total	Miles =	18,862.0	2018 Total	Hours =	481.5

**False Alarms**

False Alarms	Burglary Business	Burglary Residence	Robbery Business	Robbery Residence	Totals	Chargeable	
Nov 2019	19	16	2	0	37	37	
2019 YTD	240	194	13	0	447	447	
2018 Total	311	164	4	0	479	476	



**Assigned Cases**

<b>Statistics for Leeds, Alabama</b>	<b>Homicide</b>	<b>Rape</b>	<b>Robbery</b>	<b>Assault</b>	<b>Burglary</b>	<b>Felony Theft</b>	<b>MVT</b>
Nov 2019	0	1	2	1	2	7	0
2019 YTD	1	7	13	19	33	91	28
Cases Cleared YTD	1	6	7	17	15	48	13
Nov 2018	0	1	0	1	3	6	2
2018 YTD	0	10	5	18	67	100	19

Respectfully Submitted,

Lt. J E Loebler

**Item Attachment Documents:**

11. Fire Department: Chief Parsons

# Leeds Fire & Rescue



Le 43

This report was generated on 1/2/2020 9:53:16 AM

## Breakdown by Major Incident Types for Date Range

Zone(s): All Zones | Start Date: 12/01/2019 | End Date: 12/31/2019

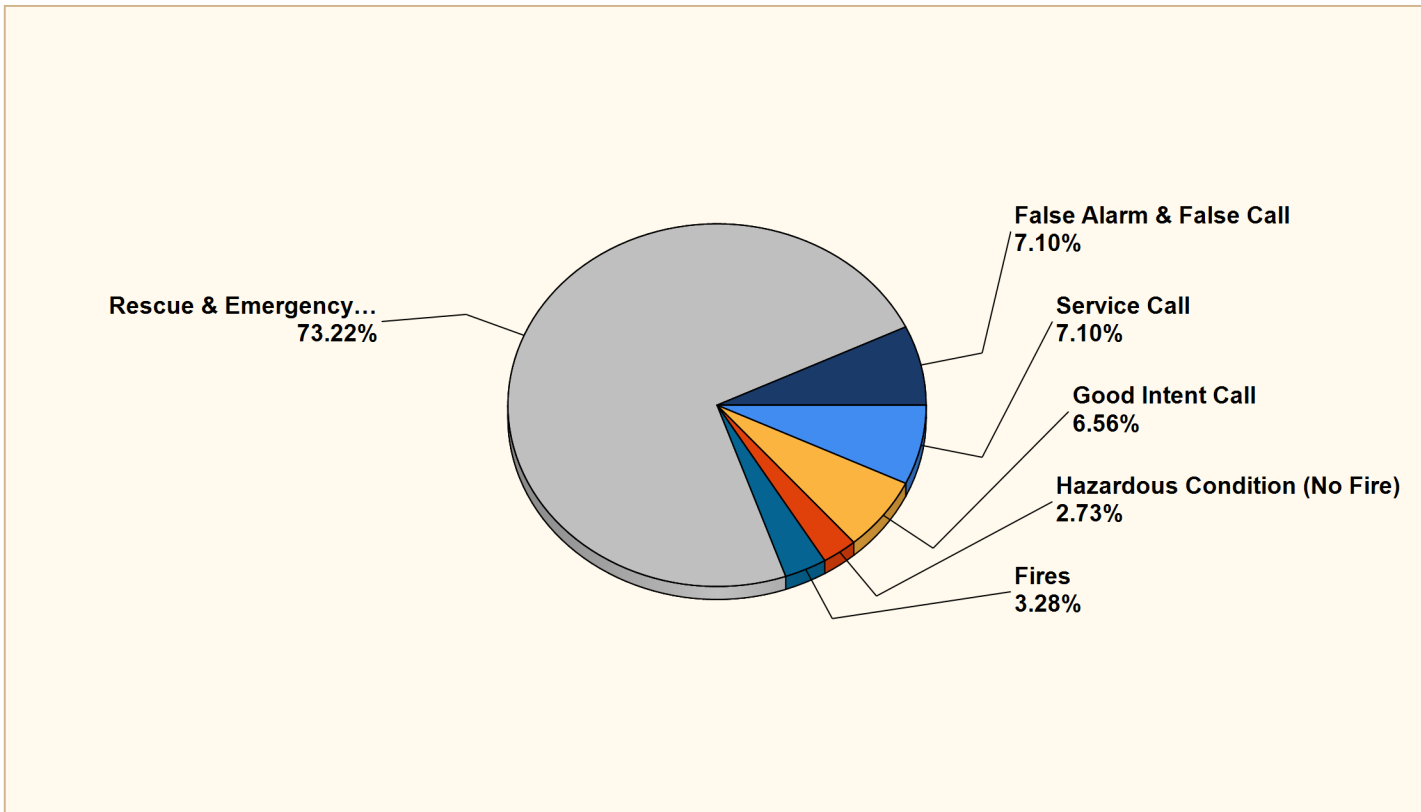

MAJOR INCIDENT TYPE	# INCIDENTS	% of TOTAL
Fires	6	3.28%
Rescue & Emergency Medical Service	134	73.22%
Hazardous Condition (No Fire)	5	2.73%
Service Call	13	7.10%
Good Intent Call	12	6.56%
False Alarm & False Call	13	7.10%
<b>TOTAL</b>	<b>183</b>	<b>100.00%</b>

Only REVIEWED incidents included. Summary results for a major incident type are not displayed if the count is zero. Does not include Imported data.



### Detailed Breakdown by Incident Type

44

INCIDENT TYPE	# INCIDENTS	% of TOTAL
111 - Building fire	1	0.55%
118 - Trash or rubbish fire, contained	1	0.55%
150 - Outside rubbish fire, other	1	0.55%
151 - Outside rubbish, trash or waste fire	3	1.64%
311 - Medical assist, assist EMS crew	1	0.55%
320 - Emergency medical service, other	1	0.55%
321 - EMS call, excluding vehicle accident with injury	116	63.39%
322 - Motor vehicle accident with injuries	6	3.28%
324 - Motor vehicle accident with no injuries.	9	4.92%
352 - Extrication of victim(s) from vehicle	1	0.55%
412 - Gas leak (natural gas or LPG)	2	1.09%
440 - Electrical wiring/equipment problem, other	1	0.55%
441 - Heat from short circuit (wiring), defective/worn	2	1.09%
500 - Service Call, other	2	1.09%
511 - Lock-out	1	0.55%
550 - Public service assistance, other	1	0.55%
551 - Assist police or other governmental agency	2	1.09%
552 - Police matter	1	0.55%
553 - Public service	1	0.55%
554 - Assist invalid	5	2.73%
611 - Dispatched & cancelled en route	6	3.28%
621 - Wrong location	1	0.55%
622 - No incident found on arrival at dispatch address	2	1.09%
651 - Smoke scare, odor of smoke	2	1.09%
671 - HazMat release investigation w/no HazMat	1	0.55%
700 - False alarm or false call, other	8	4.37%
731 - Sprinkler activation due to malfunction	1	0.55%
733 - Smoke detector activation due to malfunction	1	0.55%
743 - Smoke detector activation, no fire - unintentional	1	0.55%
745 - Alarm system activation, no fire - unintentional	2	1.09%
<b>TOTAL INCIDENTS:</b>	<b>183</b>	<b>100.00%</b>

Only REVIEWED incidents included. Summary results for a major incident type are not displayed if the count is zero. Does not include Imported data.



# Leeds Fire & Rescue

Leeds, AL

This report was generated on 1/2/2020 9:52:05 AM



## Incidents by Day of the Week for Date Range

Start Incident Type: 100 | End Incident Type: 911 | Start Date: 12/01/2019 | End Date: 12/31/2019

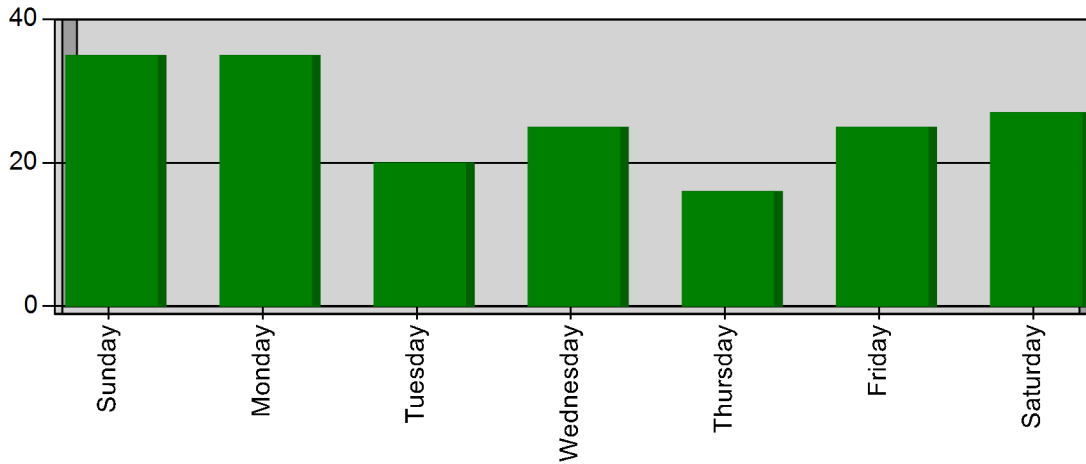

DAY OF THE WEEK	# INCIDENTS
Sunday	35
Monday	35
Tuesday	20
Wednesday	25
Thursday	16
Friday	25
Saturday	27

**TOTAL 183**

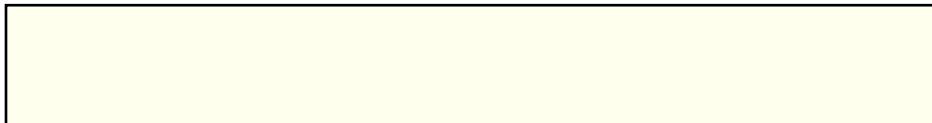



## Incident Statistics

Start Date: 01/01/2019 | End Date: 12/31/2019

INCIDENT COUNT			
INCIDENT TYPE		# INCIDENTS	
EMS		1655	
FIRE		710	
<b>TOTAL</b>		<b>2365</b>	
TOTAL TRANSPORTS (N2 and N3)			
APPARATUS	# of APPARATUS TRANSPORTS	# of PATIENT TRANSPORTS	TOTAL # of PATIENT CONTACTS
0	0	0	0
2501	0	7	7
2502	0	1	1
2503	0	19	19
2551	0	152	152
2552	0	251	251
2553	0	92	92
2571	0	1	1
2572	0	35	35
2591	1	1010	1010
<b>TOTAL</b>	<b>1</b>	<b>1568</b>	<b>1568</b>
PRE-INCIDENT VALUE		LOSSES	
<b>\$0.00</b>		<b>\$0.00</b>	
CO CHECKS			
424 - Carbon monoxide incident		1	
736 - CO detector activation due to malfunction		1	
<b>TOTAL</b>		<b>2</b>	
MUTUAL AID			
Aid Type		Total	
Aid Given		4	
Aid Received		5	
OVERLAPPING CALLS			
# OVERLAPPING		% OVERLAPPING	
582		24.61	
LIGHTS AND SIREN - AVERAGE RESPONSE TIME (Dispatch to Arrival)			
Station	EMS	FIRE	
Station 1	0:06:28	0:07:07	

Only Reviewed Incidents included. CO Checks only includes Incident Types: 424, 736 and 734. # Apparatus Transports = # of incidents where apparatus transported. # Patient Transports = # of PCR with disposition "Treated, Transported by EMS". # Patient Contacts = # of PCR contacted by apparatus. This report now returns both NEMSIS 2 & 3 data as appropriate.



Station 2	0:06:42	0:07:17
47	<b>AVERAGE FOR ALL CALLS</b>	0:06:41
<b>LIGHTS AND SIREN - AVERAGE TURNOUT TIME (Dispatch to Enroute)</b>		
<b>Station</b>	<b>EMS</b>	<b>FIRE</b>
Station 1	0:02:09	0:02:14
Station 2	0:01:59	0:02:24
<b>AVERAGE FOR ALL CALLS</b>		0:02:08
<b>AGENCY</b>	<b>AVERAGE TIME ON SCENE (MM:SS)</b>	
Leeds Fire & Rescue	18:24	

Only Reviewed Incidents included. CO Checks only includes Incident Types: 424, 736 and 734. # Apparatus Transports = # of incidents where apparatus transported. # Patient Transports = # of PCR with disposition "Treated, Transported by EMS". # Patient Contacts = # of PCR contacted by apparatus. This report now returns both NEMSIS 2 & 3 data as appropriate.





This report was generated on 1/2/2020 9:55:19 AM

## Breakdown by Major Incident Types for Date Range

Zone(s): All Zones | Start Date: 01/01/2019 | End Date: 12/31/2019

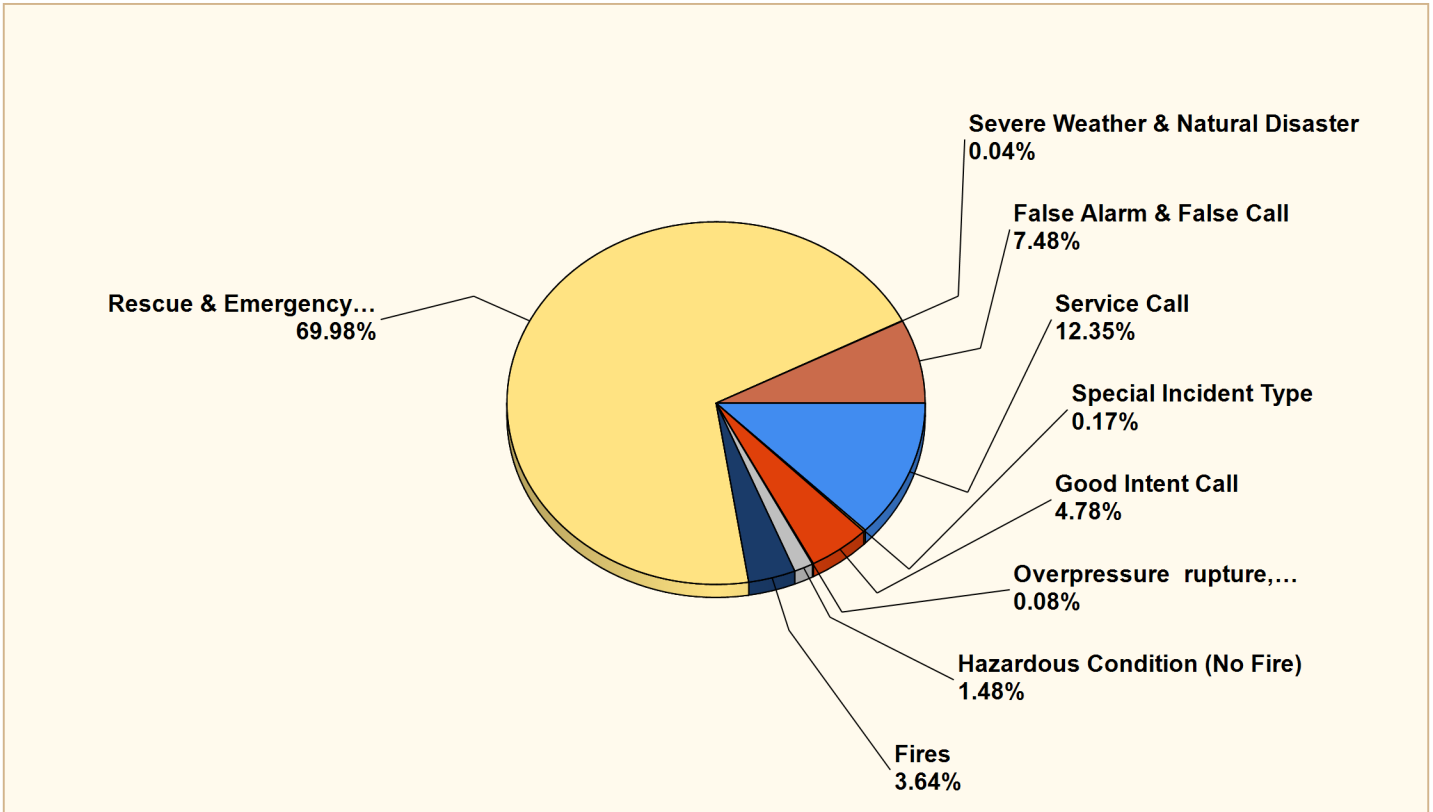

MAJOR INCIDENT TYPE	# INCIDENTS	% of TOTAL
Fires	86	3.64%
Overpressure rupture, explosion, overheating - no fire	2	0.08%
Rescue & Emergency Medical Service	1655	69.98%
Hazardous Condition (No Fire)	35	1.48%
Service Call	292	12.35%
Good Intent Call	113	4.78%
False Alarm & False Call	177	7.48%
Severe Weather & Natural Disaster	1	0.04%
Special Incident Type	4	0.17%
<b>TOTAL</b>	<b>2365</b>	<b>100.00%</b>

Only REVIEWED incidents included. Summary results for a major incident type are not displayed if the count is zero. Does not include Imported data.





### Detailed Breakdown by Incident Type

49	INCIDENT TYPE	# INCIDENTS	% of TOTAL
100 - Fire, other		8	0.34%
111 - Building fire		16	0.68%
113 - Cooking fire, confined to container		5	0.21%
118 - Trash or rubbish fire, contained		8	0.34%
121 - Fire in mobile home used as fixed residence		1	0.04%
122 - Fire in motor home, camper, recreational vehicle		1	0.04%
130 - Mobile property (vehicle) fire, other		2	0.08%
131 - Passenger vehicle fire		11	0.47%
132 - Road freight or transport vehicle fire		4	0.17%
133 - Rail vehicle fire		1	0.04%
141 - Forest, woods or wildland fire		1	0.04%
142 - Brush or brush-and-grass mixture fire		2	0.08%
143 - Grass fire		5	0.21%
150 - Outside rubbish fire, other		4	0.17%
151 - Outside rubbish, trash or waste fire		14	0.59%
160 - Special outside fire, other		2	0.08%
162 - Outside equipment fire		1	0.04%
200 - Overpressure rupture, explosion, overheat other		1	0.04%
251 - Excessive heat, scorch burns with no ignition		1	0.04%
300 - Rescue, EMS incident, other		1	0.04%
311 - Medical assist, assist EMS crew		34	1.44%
320 - Emergency medical service, other		12	0.51%
321 - EMS call, excluding vehicle accident with injury		1443	61.01%
322 - Motor vehicle accident with injuries		66	2.79%
323 - Motor vehicle/pedestrian accident (MV Ped)		2	0.08%
324 - Motor vehicle accident with no injuries.		89	3.76%
342 - Search for person in water		4	0.17%
352 - Extrication of victim(s) from vehicle		2	0.08%
354 - Trench/below-grade rescue		1	0.04%
363 - Swift water rescue		1	0.04%
400 - Hazardous condition, other		1	0.04%
411 - Gasoline or other flammable liquid spill		1	0.04%
412 - Gas leak (natural gas or LPG)		8	0.34%
424 - Carbon monoxide incident		1	0.04%
440 - Electrical wiring/equipment problem, other		10	0.42%
441 - Heat from short circuit (wiring), defective/worn		2	0.08%
444 - Power line down		9	0.38%
445 - Arcing, shorted electrical equipment		3	0.13%
500 - Service Call, other		11	0.47%
510 - Person in distress, other		2	0.08%
511 - Lock-out		6	0.25%
520 - Water problem, other		4	0.17%
522 - Water or steam leak		1	0.04%
531 - Smoke or odor removal		2	0.08%
550 - Public service assistance, other		25	1.06%
551 - Assist police or other governmental agency		30	1.27%
552 - Police matter		16	0.68%
553 - Public service		34	1.44%
554 - Assist invalid		159	6.72%
561 - Unauthorized burning		1	0.04%
571 - Cover assignment, standby, moveup		1	0.04%
600 - Good intent call, other		9	0.38%
611 - Dispatched & cancelled en route		57	2.41%
621 - Wrong location		4	0.17%
622 - No incident found on arrival at dispatch address		25	1.06%

Only REVIEWED incidents included. Summary results for a major incident type are not displayed if the count is zero. Does not include Imported data.



**Detailed Breakdown by Incident Type**

50	INCIDENT TYPE	# INCIDENTS	% of TOTAL
641	City alarm (incident in other location)	2	0.08%
651	Smoke scare, odor of smoke	11	0.47%
652	Steam, vapor, fog or dust thought to be smoke	1	0.04%
653	Smoke from barbecue, tar kettle	2	0.08%
661	EMS call, party transported by non-fire agency	1	0.04%
671	HazMat release investigation w/no HazMat	1	0.04%
700	False alarm or false call, other	110	4.65%
710	Malicious, mischievous false call, other	1	0.04%
711	Municipal alarm system, malicious false alarm	1	0.04%
714	Central station, malicious false alarm	2	0.08%
715	Local alarm system, malicious false alarm	2	0.08%
730	System malfunction, other	7	0.30%
731	Sprinkler activation due to malfunction	3	0.13%
733	Smoke detector activation due to malfunction	11	0.47%
735	Alarm system sounded due to malfunction	4	0.17%
736	CO detector activation due to malfunction	1	0.04%
740	Unintentional transmission of alarm, other	2	0.08%
743	Smoke detector activation, no fire - unintentional	15	0.63%
744	Detector activation, no fire - unintentional	6	0.25%
745	Alarm system activation, no fire - unintentional	12	0.51%
814	Lightning strike (no fire)	1	0.04%
900	Special type of incident, other	3	0.13%
911	Citizen complaint	1	0.04%
<b>TOTAL INCIDENTS:</b>		<b>2365</b>	<b>100.00%</b>

Only REVIEWED incidents included. Summary results for a major incident type are not displayed if the count is zero. Does not include Imported data.





## Incident Statistics

Start Date: 12/01/2019 | End Date: 12/31/2019

INCIDENT COUNT			
INCIDENT TYPE		# INCIDENTS	
EMS		134	
FIRE		49	
<b>TOTAL</b>		<b>183</b>	
TOTAL TRANSPORTS (N2 and N3)			
APPARATUS	# of APPARATUS TRANSPORTS	# of PATIENT TRANSPORTS	TOTAL # of PATIENT CONTACTS
0	0	0	0
2503	0	1	1
2551	0	12	12
2552	0	22	22
2553	0	1	1
2571	0	1	1
2591	0	89	89
<b>TOTAL</b>	<b>0</b>	<b>126</b>	<b>126</b>
PRE-INCIDENT VALUE		LOSSES	
<b>\$0.00</b>		<b>\$0.00</b>	
CO CHECKS			
<b>TOTAL</b>			
MUTUAL AID			
Aid Type		Total	
OVERLAPPING CALLS			
# OVERLAPPING		% OVERLAPPING	
41		22.4	
LIGHTS AND SIREN - AVERAGE RESPONSE TIME (Dispatch to Arrival)			
Station	EMS	FIRE	
Station 1	0:06:26	0:06:55	
Station 2	0:06:48	0:07:12	
<b>AVERAGE FOR ALL CALLS</b>		<b>0:06:38</b>	
LIGHTS AND SIREN - AVERAGE TURNOUT TIME (Dispatch to Enroute)			
Station	EMS	FIRE	
Station 1	0:02:07	0:02:13	
Station 2	0:02:06	0:02:01	
<b>AVERAGE FOR ALL CALLS</b>		<b>0:02:07</b>	

Only Reviewed Incidents included. CO Checks only includes Incident Types: 424, 736 and 734. # Apparatus Transports = # of incidents where apparatus transported. # Patient Transports = # of PCR with disposition "Treated, Transported by EMS". # Patient Contacts = # of PCR contacted by apparatus. This report now returns both NEMSIS 2 & 3 data as appropriate.



**AGENCY****AVERAGE TIME ON SCENE (MM:SS)**

52

Leeds Fire &amp; Rescue

17:13

Only Reviewed Incidents included. CO Checks only includes Incident Types: 424, 736 and 734. # Apparatus Transports = # of incidents where apparatus transported. # Patient Transports = # of PCR with disposition "Treated, Transported by EMS". # Patient Contacts = # of PCR contacted by apparatus. This report now returns both NEMSIS 2 & 3 data as appropriate.



# Leeds Fire & Rescue

Leeds, AL

This report was generated on 1/2/2020 9:58:00 AM



## Incidents by Day of the Week for Date Range

Start Incident Type: 100 | End Incident Type: 911 | Start Date: 01/01/2019 | End Date: 12/31/2019

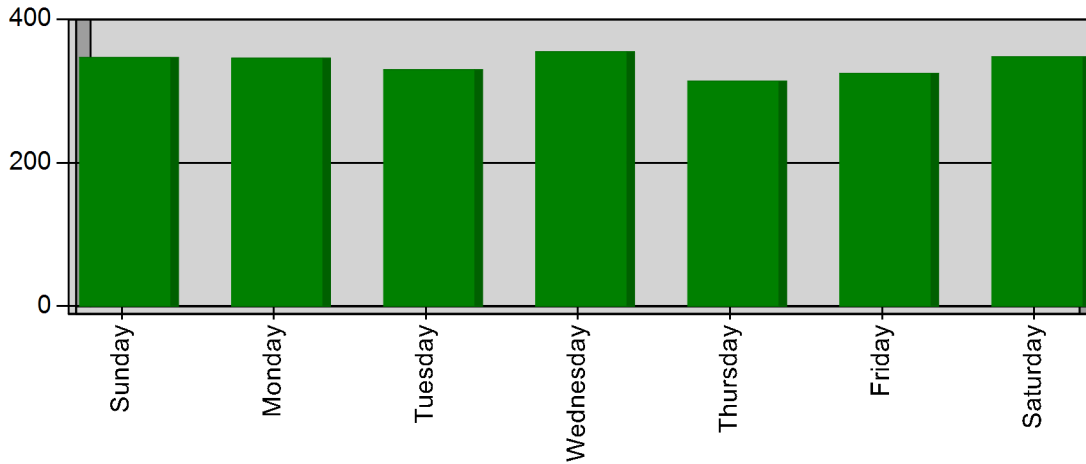

DAY OF THE WEEK	# INCIDENTS
Sunday	347
Monday	346
Tuesday	330
Wednesday	355
Thursday	314
Friday	325
Saturday	348
<b>TOTAL</b>	<b>2365</b>

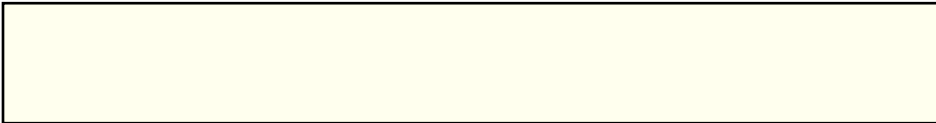

**Item Attachment Documents:**

12. Library: Library Director Carden  
Snapshot of Library accomplishments in FY 18/19  
Alabama Public Library 2018 Survey  
Alabama Public Library 2019 Survey

# Leeds Jane Culbreth Library

## Fiscal Year Report Snapshot

October 1, 2018 - September 30, 2019

**40%**

COMPUTER  
USAGE

**30%**

DIGITAL  
CHECK OUTS

**20%**

PHYSICAL  
CHECK OUTS



### TOP 10 LIBRARY

Exactly **72,570 items** were checked out at Leeds Jane Culbreth Library.

This equates to each library employee physically checking out **9,000 items** to library visitors.

### E-BOOKS & MORE

Leeds citizens have checked out **over 10,000** e-books, downloadable audio-books, movies, television, and music from Libby or Hoopla Digital.



### COMMUNITY DRIVEN

An average of 3500 people visited Leeds Jane Culbreth Library each month.



That's a total of **42,548 visitors** throughout this fiscal year!

### OVER \$100,000 AWARDED

Leeds Jane Culbreth Library was awarded 3 federal grants since October 2018.

- LSTA 2019 - Children's Nonfiction
- LSTA 2020 - Adult Nonfiction
- 21st CCLC with Leeds City Schools

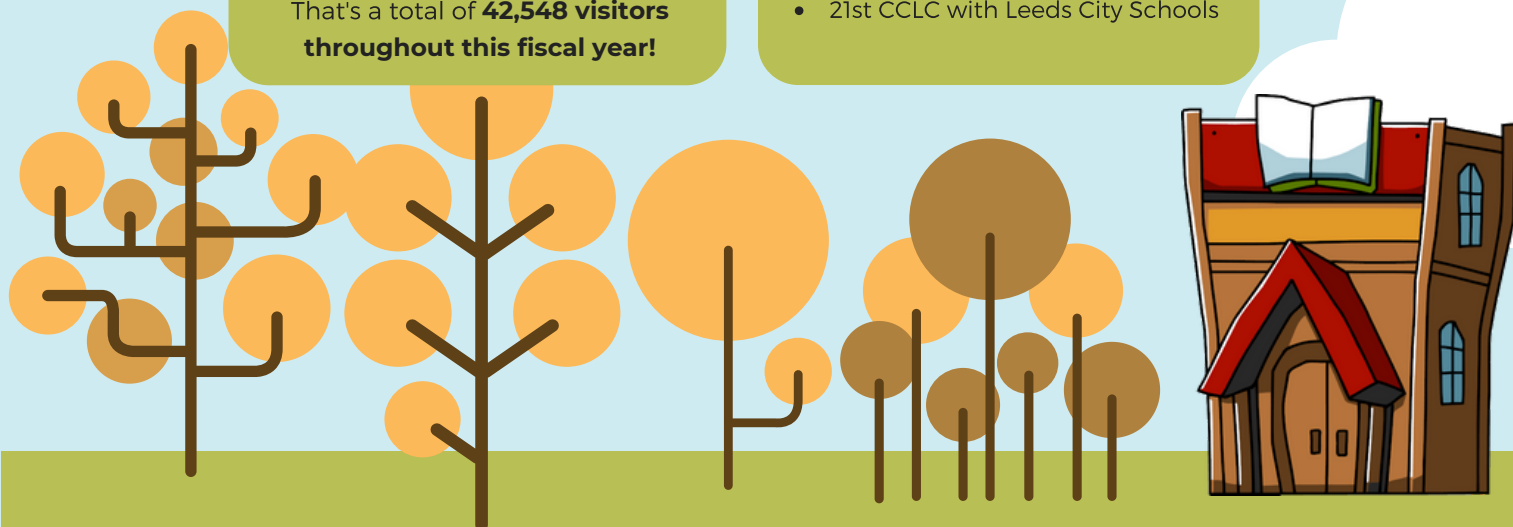

# Leeds Jane Culbreth Library 2019 Alabama Public Library Survey

## Library Identification (1.1 - 1.16)

**Date Due: December 15, 2019**

1.1	FSCS ID	AL0101
1.2	Fiscal Year of Report	October 1,2018 - September 30, 2019
1.3	Name of library	LEEDS - JANE CULBRETH LIBRARY

### Street Address

1.4	Street Address	8104 PARKWAY DRIVE
1.5	City	LEEDS
1.6	County	JEFFERSON
1.7	Zip Code	35094

### Mailing Address

1.8	Mailing Address	8104 PARKWAY DRIVE
1.9	City	LEEDS
1.10	Zip Code	35094
1.11	Phone number	(205) 699-5962
1.12	FAX Number	(205) 699-6843
1.13	Administrative E-mail Address	melanie.carden@leedslibrary.com
1.14	Librarian (Last name, First name)	Carden, Melanie
1.15	Person Completing Form	Carden, Melanie
1.16	Total Hours Open Per Week	47

## Service Outlets (2.1 - 2.8)

**Date Due: December 15, 2019**

2.1	Number of Central Libraries	1
2.2	Number of Branch Libraries	0
2.3	Number of Bookmobiles	0
2.4	Books-by-Mail	1
2.5	Other Service Outlets	0
2.6	Systems (Enter Number of Members)	0
2.7	Library System Member (Enter Name of System)	Jefferson County Library Cooperative
2.8	Does your library have a legally established Foundation/Friends Group with a 501(c)3 status	No

## Library Staff (3.1 - 3.7)

**Date Due: December 15, 2019**

3.1	Number of full time equivalent paid librarians with ALA-MLS Degree (To calculate, add hours a week worked and divide by 40)	2
3.2	Number of full time equivalent paid employees in a Librarian position without an ALA-MLS Degree (To calculate, add hours a week worked and divide by 40)	3
3.3	<b>Total full time equivalent Librarians (3.1 + 3.2)</b>	5.00



3.4	Number of all other full time equivalent paid staff	1.35
	To calculate, add hours a week worked and divide by 40)	
3.5	<b>57</b> Total full time equivalent Paid Employees (3.3 + 3.4)	6.35
3.6	Number of volunteer hours worked	312
3.7	Number of bilingual employees on the public library staff	0

### Public Service Hours (4.1 - 4.5)

**Date Due: December 15, 2019**

4.1	Total Annual Public Service Hours for Main Library	2,312
4.2	Total Annual Public Service Hours (ALL Branch Libraries)	0
4.3	Total Annual Public Service Hours for Bookmobile(s) ( <b>Do not include transportation time</b> )	0
4.4	<b>Total Public Service Hours per year (4.1 + 4.2 + 4.3)</b>	2,312
4.5	Was the MAIN library closed for more than one week due to a NATURAL disaster?	No

### Services (5.1 - 5.34)

**Date Due: December 15, 2019**

#### Users

5.1a	Number of Preschool (birth to age 5) Registered Users	25
5.1b	Number of Children (age 6 to 11) Registered Users	602
5.1c	Number of Young Adult (age 12 to 18) Registered Users	469
5.1d	Number of Adult (age 19 and up) Registered Users	3,540
5.1e	<b>Number of Registered Users (5.1a + 5.1b + 5.1c + 5.1d)</b>	4,636
5.2	Total number of library visits	42,548

#### Annual Circulation and Electronic Collection Use

5.3a	Adult, Book Circulation	18,750
5.3b	YA, Book Circulation	1,999
5.3c	Juvenile, Book Circulation	27,561
5.4	<b>Total Book Circulation (5.3a + 5.3b + 5.3c)</b>	48,310
5.5a	Adult, Electronic Material Circulation	9,916
5.5b	YA, Electronic Material Circulation	N/A
5.5c	Juvenile, Electronic Material Circulation	N/A
5.6	<b>Total Electronic Material Circulation (5.5a + 5.5b + 5.5c)</b>	9,916
5.7a	Adult, Other Physical Material Circulation	16,914
5.7b	YA, Other Physical Material Circulation	97
5.7c	Juvenile, Other Physical Material Circulation	7,249
5.8	<b>Total Other Physical Material Circulation (5.7a + 5.7b + 5.7c)</b>	24,260
5.9	<b>Total Circulation of Adult materials (5.3a + 5.5a + 5.7a)</b>	45,580
5.10	<b>Total Circulation of YA Materials (5.3b + 5.5b + 5.7b)</b>	2,096
5.11	<b>Total Circulation of Juvenile Materials (5.3c + 5.5c + 5.7c)</b>	34,810
5.12	<b>Total Circulation of Physical Items (5.4 + 5.8)</b>	72,570
5.13	Successful Retrieval of Electronic Information	7,935
5.14	<b>Total Electronic Content Use (5.6 + 5.13)</b>	17,851
5.15	<b>Total Circulation of Materials (5.4 + 5.6 + 5.8)</b>	82,486
5.16	<b>Total Collection Use (5.6 + 5.12 + 5.13)</b>	90,421

#### Reference

5.17 Total Number of Reference Transactions 37,584

### Inter-Library Loans

5.18 Inter-Library Loans Provided To Other Libraries 5,908

5.19 Inter-Library Loans Received From Other Libraries 12,354

### Program Attendance

5.20a All Adult Programs 127

5.20b All YA Programs 27

5.20c All Juvenile Programs 267

5.21 **TOTAL Library Programs (5.20a + 5.20b + 5.20c)** 421

5.22a Adult Program Attendance 3,219

5.22b YA Program Attendance 462

5.22c Juvenile Program Attendance 6,443

5.23 **TOTAL Library Program Attendance (5.22a + 5.22b + 5.22c)** 10,124

5.24 TOTAL Number of Non-English Language Programs Offered IN or OUTSIDE the Public Library Facility 3

### Automated Services

5.25 Type of Internet Connection Metro Ethernet

5.26 Internet Speed (Megabits per second) 17

5.27 Number of Computers Used by General Public 10

5.28 Annual number of uses (sessions) of Public Internet Computers 7,970

5.29 Does the library filter public use internet connections? Yes

5.30 Does your library apply for E-rate? Yes

5.31 Does the library have an integrated system for circulation, cataloging and public access catalog? Yes

5.32 Name of system's commercial vendor for circulation system/automation system Innovative Interfaces, Inc.

5.33 Wireless Sessions Annually N/A

5.34 Website Visits 4,264

## Library Collection (6.1 - 6.11)

**Date Due: December 15, 2019**

### Book Volumes

6.1 Total Book Volumes in print format 27,442

### Electronic Materials

6.2 Audio Downloadable Units 19,291

6.3 Video Downloadable Units 0

6.4 Total number of E-Books 47,960

6.5 Electronic Collections provided by State Library Agency 61

6.6 Electronic Collections provided by Reporting Library/Other Cooperative Agreement 1

6.7 **Automatically total (6.5 + 6.6)** 62

### Audio Physical Units

6.8 Total Audio Physical Units 1,171

### Video Physical Units

6.9 Total Video Physical Units 3,611

### Other

6.10 Current Print Serial Subscriptions 27

6.11 Total Other materials not counted above 28

59

## Library Operating Income (7.1 - 7.15)

**Date Due: December 15, 2019**

**Local Government Income (Include all local income appropriated to the library and/or paid directly by local government for the benefit of the library.)**

7.1	Name of City or Town	Leeds, Alabama
7.2	Library Income provided	\$416,857
7.3	Name of County	N/A
7.4	Library Income provided	N/A
7.5	<b>Total Local Government Income (7.2 + 7.4)</b>	<b>\$416,857</b>

### State Aid Income

7.6	Received directly from APLS	Yes
7.7	Received directly from a System	Yes
7.8	Total State Aid	\$7,811

### Federal Income

7.9	LSTA funds received in reporting FY	\$8,750
7.10	Other Federal funds received in reporting FY	\$0
7.11	<b>Total Federal Funds received (7.9 + 7.10)</b>	<b>\$8,750</b>

### Other Library Income

7.12	Total Other Income not reported above	\$11,330
------	---------------------------------------	----------

### Grand Total Library Operating Income

7.13	<b>Grand Total Operating Income for Reporting FY (7.5 + 7.8 + 7.11 + 7.12)</b>	<b>\$444,748</b>
7.14	Balance brought forward from previous FY	\$0
7.15	<b>Total Operating Funds Available (7.13 + 7.14)</b>	<b>\$444,748</b>

## Library Operating Expenditures (8.1 - 8.56)

**Date Due: December 15, 2019**

**Remember to include all expenditures from available funds whether from appropriations or funds paid directly by local government for the benefit of the library.**

### Personnel

#### LOCAL PERSONNEL EXPENDITURES

8.1	Local Expenditures: Salaries	\$273,857
8.2	Local Expenditures: Benefits	\$80,558
8.3	<b>Total Local Expenditures (8.1 + 8.2)</b>	<b>\$354,415</b>

#### STATE PERSONNEL EXPENDITURES

8.4	State Aid Expenditures: Salaries	\$1,770
8.5	State Aid Expenditures: Benefits	\$0
8.6	<b>Total State Aid Expenditures (8.4 + 8.5)</b>	<b>\$1,770</b>

#### FEDERAL PERSONNEL EXPENDITURES

8.7	Federal Expenditures: Salaries	\$0
8.8	Federal Expenditures: Benefits	\$0
8.9	<b>Total Federal Expenditures (8.7 + 8.8)</b>	<b>\$0</b>

#### OTHER PERSONNEL EXPENDITURES

8.10	Other Funds Expenditures: Salaries	\$0
8.11	Other Funds Expenditures: Benefits	\$0
8.11	<b>Total Other Funds Expenditures (8.10 + 8.11)</b>	\$0
<b>TOTAL PERSONNEL EXPENDITURES</b>		
8.13	<b>Total Salary Expenditures (8.1 + 8.4 + 8.7 + 8.10)</b>	\$275,627
8.14	<b>Total Benefits Expenditures (8.2 + 8.5 + 8.8 + 8.11)</b>	\$80,558
8.15	<b>Total Personnel Expenditures (8.13 + 8.14)</b>	\$356,185
<b>Collection Expenditures</b>		
<b>LOCAL COLLECTION EXPENDITURES</b>		
8.16	Local Expenditures: Print Materials	\$15,219
8.17	Local Expenditures: Electronic Materials / Downloads	\$2,000
8.18	Local Expenditures: Audio Physical Units	\$1,600
8.19	Local Expenditures: Video Physical Units	\$2,479
8.20	Local Expenditures: Other Collection Expenditures Not Reported Above	\$0
8.21	<b>Total Local Expenditures Audio, Video, Other (8.18 + 8.19 + 8.20)</b>	\$4,079
8.22	<b>Total Local Expenditures (8.16 + 8.17 + 8.21)</b>	\$21,298
<b>STATE COLLECTION EXPENDITURES</b>		
8.23	State Aid Expenditures: Print Materials	\$1,508
8.24	State Aid Expenditures: Electronic Materials / Downloads	\$0
8.25	State Aid Expenditures: Audio Physical Units	\$0
8.26	State Aid Expenditures: Video Physical Units	\$0
8.27	State Aid Expenditures: Other Collection Expenditures Not Reported Above	\$0
8.28	<b>Total State Audio, Video, and Other (8.25 + 8.26 + 8.27)</b>	\$0
8.29	<b>Total State Aid Funds (8.23 + 8.24 + 8.28)</b>	\$1,508
<b>FEDERAL COLLECTION EXPENDITURES</b>		
8.30	Federal Expenditures: Print Materials	\$6,663
8.31	Federal Expenditures: Electronic Materials / Downloads	\$0
8.32	Federal Expenditures: Audio Physical Units	\$0
8.33	Federal Expenditures: Video Physical Units	\$1,337
8.34	Federal Expenditures: Other Collection Expenditures Not Reported Above	\$750
8.35	<b>Total Federal Expenditures Audio, Video and Other (8.32 + 8.33 + 8.34)</b>	\$2,087
8.36	<b>Total Federal Expenditures (8.30 + 8.31 + 8.35)</b>	\$8,750
<b>OTHER COLLECTION EXPENDITURES</b>		
8.37	Other Funds Expenditures: Print Materials	\$0
8.38	Other Funds Expenditures: Electronic Materials / Downloads	\$0
8.39	Other Funds Expenditures: Audio Physical Units	\$0
8.40	Other Funds Expenditures: Video Physical Units	\$0
8.41	Other Funds Expenditures: Other Collection Expenditures Not Reported Above	\$0
8.42	<b>Total Other Expenditures Audio, Video, and Other (8.39 + 8.40 + 8.41)</b>	\$0
8.43	<b>Total Other Funds collection Expenditures (8.37 + 8.38 + 8.42)</b>	\$0
<b>TOTAL COLLECTION EXPENDITURES</b>		

8.44	Total Print Materials (8.16 + 8.23 + 8.30 + 8.37)	\$23,390
8.4	Total Electronic Materials / Downloads (8.17 + 8.24 + 8.31 + 38)	\$2,000
8.46	Total Audio Physical Units (8.18 + 8.25 + 8.32 + 8.39)	\$1,600
8.47	Total Video Physical Units (8.19 + 8.26 + 8.33 + 8.40)	\$3,816
8.48	Total Other Library Materials (8.20 + 8.27 + 8.34 + 8.41)	\$750
8.49	Total Audio, Video, and Other (8.21 + 8.28 + 8.35 + 8.42)	\$6,166
8.50	Total Collection (8.44 + 8.45 + 8.49)	\$31,556

**Expenditures for Library Operations**

**LOCAL LIBRARY OPERATIONS EXPENDITURES**

8.51	Local Expenditures: Library Operation and Maintenance	\$68,237
------	---	----------

**STATE LIBRARY OPERATIONS EXPENDITURES**

8.52	State Aid Expenditures: Library Operation and Maintenance	\$7,320
------	---	---------

**FEDERAL LIBRARY OPERATIONS EXPENDITURES**

8.53	Federal Expenditures: Library Operation and Maintenance	\$750
------	---	-------

**OTHER LIBRARY OPERATIONS EXPENDITURES**

8.54	Other Expenditures: Library Operation and Maintenance	\$0
------	---	-----

**TOTAL LIBRARY OPERATIONS EXPENDITURES**

8.55	Total Expenditures Library Operations and Maintenance (8.51 + 8.52 + 8.53 + 8.54)	\$76,307
------	---	----------

**Grand Total Library Expenditures**

8.56	Grand Total Library Operating Expenditures (8.15 + 8.50 + 8.55)	\$464,048
------	---	-----------

**Capital Income (9.1 - 9.5)**

**Date Due: December 15, 2019**

9.1	Local Government Capital Revenue	\$0
9.2	State Government Capital Revenue	\$0
9.3	Federal Government Capital Revenue	\$0
9.4	Other Capital Revenue	\$0
9.5	Total Capital Revenue (9.1 + 9.2 + 9.3 + 9.4)	\$0

**Capital Expenditures (10.1 - 10.5)**

**Date Due: December 15, 2019**

10.1	Capital Expenditures: Construction	\$0
10.2	Capital Expenditures: Furnishings for new building, addition or renovation	\$0
10.3	Capital Expenditures: Electronic Equipment for new building, addition or renovation	\$0
10.4	Capital Expenditures: Site acquisition and other capital not listed above	\$0
10.5	Total Capital Expenditures (10.1 + 10.2 + 10.3 + 10.4)	\$0

**Library Director's Salary Survey (11.1 - 11.5)**

**Date Due: December 15, 2019**

11.1	Current Library Director's Annual Salary	\$54,413
11.2	Average number of hours director works per week (*new question)	40
11.3	Library Director provided a retirement program?	Yes

11.4 Library Director provided health insurance? Yes

11.  Number of years reporting librarian has served as Director of this reporting library 3

## Library Board (12.1 - 12.8)

**Date Due: December 15, 2019**

Please make sure all board members are listed with their own personal contact information. Do not use the library's contact information. To add members, click the Add Group button at the bottom of the page.

12.1	Chairman or Trustee	Chairman
12.2	Board Members Name	Michael Woodall
12.3	Mailing Address	6601 Marie Circle
12.4	City	Leeds
12.5	Zip Code	35094
12.6	Phone Number	(205) 699-2964
12.7	E-mail Address	mikewoodall@windstream.net
12.8	Terms of service (Example: 2017-2020)	2017-2020
12.1	Chairman or Trustee	Trustee
12.2	Board Members Name	Stephen Reese
12.3	Mailing Address	7815 Laura Street
12.4	City	Leeds
12.5	Zip Code	35094
12.6	Phone Number	(205) 352-3313
12.7	E-mail Address	lreese@briarwood.org
12.8	Terms of service (Example: 2017-2020)	2017-2020
12.1	Chairman or Trustee	Trustee
12.2	Board Members Name	Mary Anne Moseley
12.3	Mailing Address	6615 Julia Circle
12.4	City	Leeds
12.5	Zip Code	35094
12.6	Phone Number	(205) 699-6246
12.7	E-mail Address	alphonzob@aol.com
12.8	Terms of service (Example: 2017-2020)	2017-2020
12.1	Chairman or Trustee	Trustee
12.2	Board Members Name	Vicky Dean
12.3	Mailing Address	1009 Kings Forest Drive
12.4	City	Leeds
12.5	Zip Code	35094
12.6	Phone Number	(205) 919-7380
12.7	E-mail Address	vdean11846@yahoo.com
12.8	Terms of service (Example: 2017-2020)	2019-2023
12.1	Chairman or Trustee	Trustee
12.2	Board Members Name	Terri Leigh Gibson
12.3	Mailing Address	7 Turnberry Place
12.4	City	Birmingham
12.5	Zip Code	35242
12.6	Phone Number	(205) 994-4643
12.7	E-mail Address	tgibson5384@gmail.com

12.8 Terms of service (Example: 2017-2020)

2016-2020

63

## Library Outlet Information (13.1 - 13.13)

**Date Due: December 15, 2019**

Make sure all outlets (main library, branches, bookmobiles, etc.) are listed. To add outlets, click the Add Group button at the bottom of the page.

13.1	Outlet Type Code	CE
13.2	Name of Outlet	LEEDS - JANE CULBRETH LIBRARY
13.3	Street Address	8104 PARKWAY DRIVE
13.4	Mailing Address	8104 Parkway Drive
13.5	City	LEEDS
13.6	County	JEFFERSON
13.7	Zip Code	35094
13.8	Area Code and Phone Number	(205) 699-5962
13.9	Librarian Name (Last name, First name)	Carden, Melanie
13.10	Total Usable Square Feet Available in Outlet	5000
13.11	Number of Bookmobiles in Outlet Record	0
13.12	Public Service Hours Per Year	2,312
13.13	Number of Weeks Library is Open	50

## For State Use Only (14.1 - 14.7)

**Date Due: December 15, 2019**

14.1	Interlibrary Relationship	ME
14.2	Legal Basis Code	CI
14.3	Administrative Structure Code	SO
14.4	FSCS Public Library Definition	Y
14.5	Geographic Code	CI1
14.6	Population of the Legal Service Area (same as State Aid Population as set by APLS for the reporting year).	12,031
14.7	Legal Service Area Boundary Change	N

## Leeds Jane Culbreth Library 2018 Alabama Public Library Survey

### Library Identification (1.1 - 1.16)

**Date Due: December 15, 2018**

1.1	FSCS ID	AL0101
1.2	Fiscal Year of Report	October 1,2017 - September 30, 2018
1.3	Name of library	LEEDS - JANE CULBRETH LIBRARY

#### Street Address

1.4	Street Address	8104 PARKWAY DRIVE
1.5	City	LEEDS
1.6	County	JEFFERSON
1.7	Zip Code	35094

#### Mailing Address

1.8	Mailing Address	8104 PARKWAY DRIVE
1.9	City	LEEDS
1.10	Zip Code	35094
1.11	Phone number	(205) 699-5962
1.12	FAX Number	(205) 699-6843
1.13	Administrative E-mail Address	mcarden@bham.lib.al.us
1.14	Librarian (Last name, First name)	Carden, Melanie
1.15	Person Completing Form	Melanie Carden
1.16	Total Hours Open Per Week	47

### Service Outlets (2.1 - 2.8)

**Date Due: December 15, 2018**

2.1	Number of Central Libraries	1
2.2	Number of Branch Libraries	0
2.3	Number of Bookmobiles	0
2.4	Books-by-Mail	1
2.5	Other Service Outlets	0
2.6	Systems (Enter Number of Members)	0
2.7	Library System Member (Enter Name of System)	Jefferson County Library Cooperative
2.8	Does your library have a legally established Foundation with a 501(c)3 status	No

### Library Staff (3.1 - 3.7)

**Date Due: December 15, 2018**

3.1	Number of full time equivalent paid librarians with ALA-MLS Degree (To calculate, add hours a week worked and divide by 40)	2
3.2	Number of full time equivalent paid employees in a Librarian position without an ALA-MLS Degree (To calculate, add hours a week worked and divide by 40)	3
3.3	<b>Total full time equivalent Librarians (3.1 + 3.2)</b>	<b>5.00</b>



3.4	Number of all other full time equivalent paid staff to calculate, add hours a week worked and divide by 40)	2.3
3.5	<b>65</b> Total full time equivalent Paid Employees (3.3 + 3.4)	7.30
3.6	Number of volunteer hours worked	312
3.7	Number of bilingual employees on the public library staff	0

### Public Service Hours (4.1 - 4.5)

**Date Due: December 15, 2018**

4.1	Total Annual Public Service Hours for Main Library	2,312
4.2	Total Annual Public Service Hours (ALL Branch Libraries)	0
4.3	Total Annual Public Service Hours for Bookmobile(s) ( <b>Do not include transportation time</b> )	0
4.4	<b>Total Public Service Hours per year (4.1 + 4.2 + 4.3)</b>	2,312
4.5	Was the MAIN library closed for more than one week due to a NATURAL disaster?	No

### Services (5.1 - 5.34)

**Date Due: December 15, 2018**

#### Users

5.1a	Number of Preschool (birth to age 5) Registered Users	27
5.1b	Number of Children (age 6 to 11) Registered Users	635
5.1c	Number of Young Adult (age 12 to 18) Registered Users	491
5.1d	Number of Adult (age 19 and up) Registered Users	3,854
5.1e	<b>Number of Registered Users (5.1a + 5.1b + 5.1c + 5.1d)</b>	5,007
5.2	Total number of library visits	45,950

#### Annual Circulation and Electronic Collection Use

5.3a	Adult, Book Circulation	17,004
5.3b	YA, Book Circulation	1,656
5.3c	Juvenile, Book Circulation	22,001
5.4	<b>Total Book Circulation (5.3a + 5.3b + 5.3c)</b>	40,661
5.5a	Adult, Electronic Material Circulation	7,611
5.5b	YA, Electronic Material Circulation	0
5.5c	Juvenile, Electronic Material Circulation	0
5.6	<b>Total Electronic Material Circulation (5.5a + 5.5b + 5.5c)</b>	7,611
5.7a	Adult, Other Physical Material Circulation	14,586
5.7b	YA, Other Physical Material Circulation	132
5.7c	Juvenile, Other Physical Material Circulation	5,532
5.8	<b>Total Other Physical Material Circulation (5.7a + 5.7b + 5.7c)</b>	20,250
5.9	<b>Total Circulation of Adult materials (5.3a + 5.5a + 5.7a)</b>	39,201
5.10	<b>Total Circulation of YA Materials (5.3b + 5.5b + 5.7b)</b>	1,788
5.11	<b>Total Circulation of Juvenile Materials (5.3c + 5.5c + 5.7c)</b>	27,533
5.12	<b>Total Circulation of Physical Items (5.4 + 5.8)</b>	60,911
5.13	Successful Retrieval of Electronic Information	29,986
5.14	<b>Total Electronic Content Use (5.6 + 5.13)</b>	37,597
5.15	<b>Total Circulation of Materials (5.4 + 5.6 + 5.8)</b>	68,522
5.16	<b>Total Collection Use (5.6 + 5.12 + 5.13)</b>	98,508

#### Reference

5.17 Total Number of Reference Transactions 36,900

**Inter-Library Loans**

5.18 Inter-Library Loans Provided To Other Libraries 6,504

5.19 Inter-Library Loans Received From Other Libraries 11,266

**Program Attendance**

5.20a All Adult Programs 76

5.20b All YA Programs 22

5.20c All Juvenile Programs 293

5.21 **TOTAL Library Programs (5.20a + 5.20b + 5.20c)** 391

5.22a Adult Program Attendance 919

5.22b YA Program Attendance 124

5.22c Juvenile Program Attendance 8,730

5.23 **TOTAL Library Program Attendance (5.22a + 5.22b + 5.22c)** 9,773

5.24 TOTAL Number of Non-English Language Programs Offered IN or OUTSIDE the Public Library Facility 5

**Automated Services**

5.25 Type of Internet Connection Metro Ethernet

5.26 Internet Speed (Megabits per second) 17

5.27 Number of Computers Used by General Public 10

5.28 Annual number of uses (sessions) of Public Internet Computers 5,694

5.29 Does the library filter public use internet connections? Yes

5.30 Does your library apply for E-rate? Yes

5.31 Does the library have an integrated system for circulation, cataloging and public access catalog? Yes

5.32 Name of system's commercial vendor for circulation system/automation system Innovative Interfaces, Inc.

5.33 Wireless Sessions Annually N/A

5.34 Website Visits (\*New Question) N/A

**Library Collection (6.1 - 6.11)**

**Date Due: December 15, 2018**

**Book Volumes**

6.1 Total Book Volumes in print format 29,566

**Electronic Materials**

6.2 Audio Downloadable Units 22,962

6.3 Video Downloadable Units 0

6.4 E-Books 59,698

6.5 Electronic Collections provided by State Library Agency 61

6.6 Electronic Collections provided by Reporting Library/Other Cooperative Agreement 1

6.7 **Automatically total (6.5 + 6.6)** 62

**Audio Physical Units**

6.8 Total Audio Physical Units 1,202

**Video Physical Units**

6.9 Total Video Physical Units 3,697

**Other**

6.10 Current Print Serial Subscriptions 29

6.11 Total Other materials 11

67

**Library Operating Income (7.1 - 7.15)**

**Date Due: December 15, 2018**

**Local Government Income (Include all local income appropriated to the library and/or paid directly by local government for the benefit of the library.)**

7.1	Name of City or Town	Leeds, Alabama
7.2	Library Income provided	\$434,499
7.3	Name of County	Jefferson
7.4	Library Income provided	\$0
7.5	<b>Total Local Government Income (7.2 + 7.4)</b>	<b>\$434,499</b>

**State Aid Income**

7.6	Received directly from APLS	No
7.7	Received directly from a System	Yes
7.8	Total State Aid	\$7,566

**Federal Income**

7.9	LSTA funds received in reporting FY	\$0
7.10	Other Federal funds received in reporting FY	\$0
7.11	<b>Total Federal Funds received (7.9 + 7.10)</b>	<b>\$0</b>

**Other Library Income**

7.12	Total Other Income	\$14,858
------	--------------------	----------

**Grand Total Library Operating Income**

7.13	<b>Grand Total Operating Income for Reporting FY (7.5 + 7.8 + 7.11 + 7.12)</b>	<b>\$456,923</b>
7.14	Balance brought forward from previous FY	\$0
7.15	<b>Total Operating Funds Available (7.13 + 7.14)</b>	<b>\$456,923</b>

**Library Operating Expenditures (8.1 - 8.56)**

**Date Due: December 15, 2018**

**Remember to include all expenditures from available funds whether from appropriations or funds paid directly by local government for the benefit of the library.**

**Personnel**

**LOCAL PERSONNEL EXPENDITURES**

8.1	Local Expenditures: Salaries	\$260,000
8.2	Local Expenditures: Benefits	\$49,805
8.3	<b>Total Local Expenditures (8.1 + 8.2)</b>	<b>\$309,805</b>

**STATE PERSONNEL EXPENDITURES**

8.4	State Aid Expenditures: Salaries	\$725
8.5	State Aid Expenditures: Benefits	\$0
8.6	<b>Total State Aid Expenditures (8.4 + 8.5)</b>	<b>\$725</b>

**FEDERAL PERSONNEL EXPENDITURES**

8.7	Federal Expenditures: Salaries	\$0
8.8	Federal Expenditures: Benefits	\$0
8.9	<b>Total Federal Expenditures (8.7 + 8.8)</b>	<b>\$0</b>

**OTHER PERSONNEL EXPENDITURES**

8.10	Other Funds Expenditures: Salaries	\$0
8.11	Other Funds Expenditures: Benefits	\$0
8.11	<b>Total Other Funds Expenditures (8.10 + 8.11)</b>	\$0

**TOTAL PERSONNEL EXPENDITURES**

8.13	<b>Total Salary Expenditures (8.1 + 8.4 + 8.7 + 8.10)</b>	\$260,725
8.14	<b>Total Benefits Expenditures (8.2 + 8.5 + 8.8 + 8.11)</b>	\$49,805
8.15	<b>Total Personnel Expenditures (8.13 + 8.14)</b>	\$310,530

**Collection Expenditures**

**LOCAL COLLECTION EXPENDITURES**

8.16	Local Expenditures: Print Materials	\$12,872
8.17	Local Expenditures: Electronic Materials / Downloads	\$940
8.18	Local Expenditures: Audio Physical Units	\$1,062
8.19	Local Expenditures: Video Physical Units	\$3,582
8.20	Local Expenditures: Other	\$0
8.21	<b>Total Local Expenditures Audio, Video, Other (8.18 + 8.19 + 8.20)</b>	\$4,644
8.22	<b>Total Local Expenditures (8.16 + 8.17 + 8.21)</b>	\$18,456

**STATE COLLECTION EXPENDITURES**

8.23	State Aid Expenditures: Print Materials	\$1,453
8.24	State Aid Expenditures: Electronic Materials / Downloads	\$0
8.25	State Aid Expenditures: Audio Physical Units	\$0
8.26	State Aid Expenditures: Video Physical Units	\$50
8.27	State Aid Expenditures: Other Nonbook	\$0
8.28	<b>Total State Audio, Video, and Other (8.25 + 8.26 + 8.27)</b>	\$50
8.29	<b>Total State Aid Funds (8.23 + 8.24 + 8.28)</b>	\$1,503

**FEDERAL COLLECTION EXPENDITURES**

8.30	Federal Expenditures: Print Materials	\$0
8.31	Federal Expenditures: Electronic Materials / Downloads	\$0
8.32	Federal Expenditures: Audio Physical Units	\$0
8.33	Federal Expenditures: Video Physical Units	\$0
8.34	Federal Expenditures: Other Nonbook	\$0
8.35	<b>Total Federal Expenditures Audio, Video and Other (8.32 + 8.33 + 8.34)</b>	\$0
8.36	<b>Total Federal Expenditures (8.30 + 8.31 + 8.35)</b>	\$0

**OTHER COLLECTION EXPENDITURES**

8.37	Other Funds Expenditures: Print Materials	\$0
8.38	Other Funds Expenditures: Electronic Materials / Downloads	\$0
8.39	Other Funds Expenditures: Audio Physical Units	\$0
8.40	Other Funds Expenditures: Video Physical Units	\$0
8.41	Other Funds Expenditures: Other Nonbook	\$0
8.42	<b>Total Other Expenditures Audio, Video, and Other (8.39 + 8.40 + 8.41)</b>	\$0
8.43	<b>Total Other Funds collection Expenditures (8.37 + 8.38 + 8.42)</b>	\$0

**TOTAL COLLECTION EXPENDITURES**

8.44	<b>Total Print Materials (8.16 + 8.23 + 8.30 + 8.37)</b>	\$14,325
8.45	<b>Total Electronic Materials / Downloads (8.17 + 8.24 + 8.31 + 8.38)</b>	\$940
8.46	<b>Total Audio Physical Units (8.18 + 8.25 + 8.32 + 8.39)</b>	\$1,062
8.47	<b>Total Video Physical Units (8.19 + 8.26 + 8.33 + 8.40)</b>	\$3,632

8.48	Total Other Library Materials (8.20 + 8.27 + 8.34 + 8.41)	\$0
8.4	Total Audio, Video, and Other (8.21 + 8.28 + 8.35 + 8.42)	\$4,694
8.5	Total Collection (8.44 + 8.45 + 8.49)	\$19,959

### Expenditures for Library Operations

#### LOCAL LIBRARY OPERATIONS EXPENDITURES

8.51	Local Expenditures: Library Operation and Maintenance	\$62,000
------	---	----------

#### STATE LIBRARY OPERATIONS EXPENDITURES

8.52	State Aid Expenditures: Library Operation and Maintenance	\$5,338
------	---	---------

#### FEDERAL LIBRARY OPERATIONS EXPENDITURES

8.53	Federal Expenditures: Library Operation and Maintenance	\$0
------	---	-----

#### OTHER LIBRARY OPERATIONS EXPENDITURES

8.54	Other Expenditures: Library Operation and Maintenance	\$0
------	---	-----

#### TOTAL LIBRARY OPERATIONS EXPENDITURES

8.55	Total Expenditures Library Operations and Maintenance (8.51 + 8.52 + 8.53 + 8.54)	\$67,338
------	---	----------

#### Grand Total Library Expenditures

8.56	Grand Total Library Operating Expenditures (8.15 + 8.50 + 8.55)	\$397,827
------	---	-----------

### Capital Income (9.1 - 9.5)

**Date Due: December 15, 2018**

9.1	Local Government Capital Revenue	\$0
9.2	State Government Capital Revenue	0
9.3	Federal Government Capital Revenue	0
9.4	Other Capital Revenue	0
9.5	Total Capital Revenue (9.1 + 9.2 + 9.3 + 9.4)	\$0

### Capital Expenditures (10.1 - 10.5)

**Date Due: December 15, 2018**

10.1	Capital Expenditures: Construction	\$0
10.2	Capital Expenditures: Furnishings for new building, addition or renovation	0
10.3	Capital Expenditures: Electronic Equipment for new building, addition or renovation	0
10.4	Capital Expenditures: Site acquisition and other capital not listed above	0
10.5	Total Capital Expenditures (10.1 + 10.2 + 10.3 + 10.4)	\$0

### Library Director's Salary Survey (11.1 - 11.5)

**Date Due: December 15, 2018**

11.1	Current Library Director's Annual Salary	\$48,152
11.2	Average number of hours director works per week (*new question)	40
11.3	Library Director provided a retirement program?	Yes
11.4	Library Director provided health insurance?	Yes
11.5	Number of years reporting librarian has served as Director of this reporting library	2

### Library Board (12.1 - 12.8)

**Date Due: December 15, 2018**

Please 70 make sure all board members are listed with their own personal contact information. Do not use the library's contact information. To add members, click the Add Group button at the bottom of the page.

12.1	Chairman or Trustee	Chairman
12.2	Board Members Name	Michael Woodall
12.3	Mailing Address	6601 Marie Circle
12.4	City	Leeds
12.5	Zip Code	35094
12.6	Phone Number	(205) 699-2964
12.7	E-mail Address	mikewoodall@windstream.net
12.8	Terms of service (Example: 2017-2020)	2017-2020
12.1	Chairman or Trustee	Trustee
12.2	Board Members Name	Stephen Reese
12.3	Mailing Address	7815 Laura Street
12.4	City	Leeds
12.5	Zip Code	35094
12.6	Phone Number	(205) 352-3313
12.7	E-mail Address	lreese@briarwood.org
12.8	Terms of service (Example: 2017-2020)	2017-2020
12.1	Chairman or Trustee	Trustee
12.2	Board Members Name	Mary Anne Moseley
12.3	Mailing Address	6615 Julia Circle
12.4	City	Leeds
12.5	Zip Code	35094
12.6	Phone Number	(205) 699-6246
12.7	E-mail Address	alphonzob@aol.com
12.8	Terms of service (Example: 2017-2020)	2017-2020
12.1	Chairman or Trustee	Trustee
12.2	Board Members Name	Vicky Dean
12.3	Mailing Address	1009 Kings Forest Drive
12.4	City	Leeds
12.5	Zip Code	35094
12.6	Phone Number	(205) 919-7380
12.7	E-mail Address	vdean11846@yahoo.com
12.8	Terms of service (Example: 2017-2020)	2016-2019
12.1	Chairman or Trustee	Trustee
12.2	Board Members Name	Terri Leigh Gibson
12.3	Mailing Address	7 Turnberry Place
12.4	City	Birmingham
12.5	Zip Code	35242
12.6	Phone Number	(205) 994-4643
12.7	E-mail Address	tgibson5384@gmail.com
12.8	Terms of service (Example: 2017-2020)	2016-2020

**Library Outlet Information (13.1 - 13.13)**

**Date Due: December 15, 2018**

Make 71 all outlets (main library, branches, bookmobiles, etc.) are listed. To add outlets, click the Add Group button at the bottom of the page.

13.1	Outlet Type Code	CE
13.2	Name of Outlet	LEEDS - JANE CULBRETH LIBRARY
13.3	Street Address	8104 PARKWAY DRIVE
13.4	Mailing Address	8104 Parkway Drive
13.5	City	LEEDS
13.6	County	JEFFERSON
13.7	Zip Code	35094
13.8	Area Code and Phone Number	(205) 699-5962
13.9	Librarian Name (Last name, First name)	Carden, Melanie
13.10	Total Usable Square Feet Available in Outlet	5000
13.11	Number of Bookmobiles in Outlet Record	0
13.12	Public Service Hours Per Year	2,312
13.13	Number of Weeks Library is Open	50

**For State Use Only (14.1 - 14.7)**

**Date Due: December 15, 2018**

14.1	Interlibrary Relationship	ME
14.2	Legal Basis Code	CI
14.3	Administrative Structure Code	SO
14.4	FSCS Public Library Definition	Y
14.5	Geographic Code	C11
14.6	Population of the Legal Service Area (same as State Aid Population as set by APLS for the reporting year).	11,940
14.7	Legal Service Area Boundary Change	N

**Item Attachment Documents:**

- 14. Development Services Department: Zoning Administrator Watson



**73 Department Hours- OT**

**11/19/19 to 12/02/19**

<b>Department</b>	<b>OT</b>	<b>COM</b>	<b>PDC</b>	<b>FDC</b>	<b>Totals</b>
	<b>181:18</b>	<b>7:25</b>	<b>4:00</b>	<b>91:00</b>	<b>283:43</b>
FINANCE	4:32				4:32
FIRE	52:00			91:00	143:00
LIBRARY	2:45	4:55			7:40
P&R	3:14				3:14
POLICE	106:36		4:00		110:36
STREET	12:11	2:30			14:41

**74 Department Hours- OT**

**12/03/19 to 12/16/19**

<b>Department</b>	<b>OT</b>	<b>COM</b>	<b>FDC</b>	<b>Totals</b>
-------------------	-----------	------------	------------	---------------

ADMIN	0:30			0:30
COURT		55:45		55:45
DEV	2:51			2:51
FINANCE	3:05			3:05
FIRE	205:00		21:45	226:45
LIBRARY	4:30			4:30
P&R	4:36			4:36
POLICE	80:55			80:55
STREET	49:20			49:20

**75 Department Hours- OT**

12/17/19 to 12/30/19

Department	OT	COM	PDC	FDC	Totals
	143:42	56:15	10:00	2:30	212:27

FIRE	2:00			2:30	4:30
LIBRARY		56:15			56:15
POLICE	141:42		10:00		151:42

**Item Attachment Documents:**

16. Ordinance 2019-12-01 (Carried over from the canceled meeting - December 16, 2019)  
Consider Establishing Post-Construction Best Management Practices for Permanent Storm  
Water Control Structures (Budget Neutral)

# CITY OF LEEDS

## ORDINANCE NO. 2019-12-01

### STORMWATER MANAGEMENT POST-CONSTRUCTION ORDINANCE

#### SUMMARY: AN ORDINANCE ESTABLISHING POST-CONSTRUCTION BEST MANAGEMENT PRACTICES FOR PERMANENT STORMWATER CONTROL STRUCTURES

THE PUBLIC GOOD REQUIRING IT, BE IT ORDAINED BY THE CITY COUNCIL OF THE CITY OF LEEDS, ALABAMA AS FOLLOWS:

**WHEREAS**, the City of Leeds operates under the requirements of the Alabama Department of Environmental Management (ADEM) National Pollutant Discharge Elimination System (NPDES) Permit ALR040047; and

**WHEREAS**, this permit authorizes stormwater discharges from regulated small municipal separate storm sewer systems (MS4s); and

**WHEREAS**, the City of Leeds must be compliant with the ADEM NPDES Permit by developing, implementing, and enforcing a program to address post-construction stormwater management; and

**WHEREAS**, the City of Leeds finds it necessary to enact an ordinance to address and enforce post-construction stormwater management standards on Qualifying Sites to prevent or minimize water quality impacts and ensure that the volume and velocity of pre-construction stormwater runoff is not exceeded for the life of the property’s use to the maximum extent practical (MEP)

Be it Ordained as follows:

### Section 1 DEFINITIONS

For the purposes of this ordinance, the following words and terms shall have the meaning assigned to them in this section.

*Best Management Practices (BMPs)* –activities, prohibitions of practices, maintenance procedures and management practices designed to prevent or reduce the pollution of waters to the MS4. BMPs also include treatment systems, operating procedures, and practices to control facility site runoff, spillage or leaks, sludge or water disposal, or drainage from raw material storage.

*Green Infrastructure* – Systems and practices that use or mimic natural processes to infiltrate, promote evapotranspiration (the return of water to the atmosphere either through evaporation or by plants), or reuse stormwater or runoff on the site where it is generated.

*Hydrology* –the physical characteristics of stormwater discharge, including the magnitude, duration, frequency, and timing of discharge.

*Low Impact Development (LID)* –An approach to land development (or re-development) that works with nature to manage stormwater as close to its source as possible. LID employs principles such as preserving and recreating natural landscape features, minimizing effective imperviousness, to create functional and appealing site drainage that treats stormwater as a resource rather than a waste product. *Non-structural BMPs* –may include, but not be limited to the following: preservation of open spaces and vegetation, establishment of

conservation easements, establishment of buffers along streams and other waters, maintenance of vegetation, BMP inspection and maintenance, and planning for future development or redevelopment.

*Qualifying Site* –any new development site or re-development site that results in land disturbance and implements Structural and/or Non-structural BMPs.

*Structural BMPs* –may include, but not be limited to the following: detention/retention devices, check dams, drainage swales, lined ditches, infiltration basins, porous pavement, outlet protection, velocity dissipation devices, slope protection, constructed wetlands, rain gardens, catch basin inserts, vegetated filter strips, and rain barrels.

**Section 2  
ADMINISTRATION**

The provisions of this ordinance shall be administered by a municipal official or employee who is a qualified credentialed professional (QCP), such other municipal official or municipal employee who has had sufficient experience with BMP design, or an individual or agency contracted by the City to provide such service.

**Section 3  
POST-CONSTRUCTION BMP DESIGN**

**Section 3.1 Design Standards**

The post-construction BMPs for Qualifying Sites, which may include a combination of structural BMPs and/or non-structural BMPs, must be designed to ensure that the volume and velocity of preconstruction stormwater runoff, to the maximum extent practicable, is not exceeded.

Landowners and developers must develop and maintain best management practices to ensure, to the maximum extent practicable, that post-construction hydrology mimics pre-construction hydrology of the site. A 25-year, 24-hour rain event shall be the basis for the design and implementation of post- construction BMPs.

The current City of Leeds Subdivision and Development Regulations details acceptable design criteria meeting the requirement of the current NPDES Permit No. ALS000011 and shall be the basis for the design and implementation of post-construction BMPs.

**Section 3.2 Design References**

By reference in this Section, the City adopts the following as design references to meet the design standards:

- a) The latest version of the “Alabama Handbook for Erosion Control, Sedimentation Control, and Stormwater Management on Construction Sites and Urban Areas”, Volumes 1 and 2.
- b) The latest version of the “Low Impact Development Handbook for the State of Alabama”.
- c) Any stormwater design manual approved by the City that meets the design requirement of this ordinance.

**Section 4 APPLICATION REQUIREMENTS**

As part of the Land Disturbance Application, all Qualifying Sites shall include the following components:

**Section 4.1 Post-Construction BMP Design Description**

Structural BMPs and/or non-structural BMPs that meet the design standards for Qualifying Sites found in Section 3.1 of this ordinance will be submitted to the City for review and approval. Submittal of a post-construction BMP plan, for approval by the City, must be included as an integral part of the site-plan approval process.

Changes to design of any structural or non-structural BMPs should be submitted to the City as a Revision. All Revisions must be submitted and stamped by a design professional, reviewed for compliance, and approved prior to construction. All approved plans and Revisions will remain in the project address folder and serve as “as-built” certification once the Certificate of Occupancy/Completion is issued.

#### **Section 4.2 Post-Construction BMP Inspection Plan Description**

The City shall perform or require the performance of an inspection by the developer/owner/operator at least once per year to confirm proper function of BMPs, require corrective actions to poorly functioning or inadequately maintained BMPs, and require record keeping of maintenance activities, inspections, and corrective actions. Records of these inspections shall be made available to ADEM upon request and copies shall be provided to the City on an annual basis. The minimum documentation requirements for inspections are as follows:

- a) Facility type;
- b) Inspection date;
- c) Name and signature of qualified inspector;
- d) Site location;
- e) Owner information (name, address, phone number, and email);
- f) Checklist of BMP's that must be inspected and required condition of BMP's to ensure proper functioning. Description of the existing stormwater BMP condition that may include the quality of: vegetation and soils, inlet and outlet channels and structures, embankments, slopes, and safety benches; permeable paving; spillways, weirs, and other control structures; and sediment and debris accumulation in storage and forebay areas as well as in and around inlet and outlet structures;
- g) Photographic documentation of all critical stormwater BMP components;
- h) Specific maintenance items or violations to be addressed by the responsible party of the stormwater control or BMPs; and
- i) Maintenance agreements for long-term BMP operations and maintenance.

#### **Section 4.3 Post-Construction BMP Operation and Maintenance Plan Description**

A BMP Operation and Maintenance Plan shall be a part of the plan review process and an executed copy shall be placed in the project address folder and the MS4 Post-Construction folder. The plan shall identify the necessary reoccurring maintenance and operational activities and schedule of those activities necessary to ensure that the BMPs continue to meet the original design intent and standards of this ordinance. The Operation and Maintenance Plan shall also designate the party that is responsible and funding mechanism necessary to implement the Plan.

One or more of the following shall be applicable (as determined by the City) to establish the responsible party for long term operation and maintenance:

- a) The developer's signed statement accepting responsibility for maintenance until the maintenance responsibility is legally transferred to another party.
- b) Written conditions in the sales or lease agreement that require the recipient to assume responsibility for maintenance.
- c) Written conditions in projection conditions, covenants, and restrictions for residential properties assigning maintenance responsibilities to a homeowner's association or other appropriate group for maintenance of structural and treatment control management practices.
- d) Any other legally enforceable agreement that assigns permanent responsibility for maintenance.

**Section 5  
ENFORCEMENT AND ABATEMENT**

If the responsible party fails or refuses to meet design, operation, or maintenance standards required by this ordinance, the City, after reasonable notice, may correct a violation of the design standards, operations, or maintenance needs by performing all necessary work to place the measures in proper working condition. In the event the BMPs become a danger to public safety or public health, which includes water quality, the City shall notify in writing the responsible party for changes to design, operation, maintenance, and repairs of the BMP. Upon receipt of that notice, the responsible party shall have 14 calendar days, or such additional time as the City shall determine to be reasonably necessary to complete the actions, to make changes to design, operation, maintenance, and repairs of the measures in an approved manner. In the event corrective action is not undertaken within that time, the City may take necessary corrective action. The cost of any action by the City under this Section shall be billed to the responsible party. If the responsible party refuses to pay the bill, the City is entitled to bring an action against the responsible party to pay, file a lien against the property, or both. Costs shall include interest, collection fees, and reasonable attorney fees. The City shall also have the authority to issue a Stop Work Order on any other components of the development to ensure that the BMPs are properly installed and maintained.

**Section 6  
MISCELLANEOUS**

**Section 6.1 Notices**

Whenever the City is required or permitted to:

- a) Give a notice to any party, such notice must be in writing; or
- b) Deliver a document to any party; such notice or document may be delivered by personal delivery, certified mail (return receipt requested), registered mail (return receipt requested) or a generally recognized overnight carrier, to the address of such party which is in the records of the City or is otherwise known to the City.

**Section 6.2 References**

Whenever a Section is referred to in this ordinance, unless the context clearly indicates the contrary, such reference shall be to a section of this ordinance.

**Section 6.3 Severability**

The provisions of this ordinance are severable. If any part of this ordinance is determined by a court of law to be invalid, unenforceable or unconstitutional, such determination shall not affect any other part of this ordinance.

**Section 6.4 Captions**

The captions of Sections and sections are for the purpose of reference only, and such captions shall not affect the meaning of any provision of this ordinance.

**Section 6.5 Ultimate Responsibility**

The standards set forth herein and promulgated pursuant to this ordinance are minimum standards; therefore, this ordinance does not intend nor imply that compliance by any person will ensure that there will be no contamination, pollution, nor unauthorized discharge of pollutants.

This Ordinance shall become effective upon its passage, execution and publication as provided by law.



**ADOPTED AND APPROVED** at a regular meeting of the City Council of the City of Leeds, Alabama on this the 6<sup>th</sup> day of January 2020

**CITY OF LEEDS, ALABAMA**

\_\_\_\_\_  
David Miller, Mayor

\_\_\_\_\_  
DATE

**AYES:** \_\_\_\_\_  
**NAYS:** \_\_\_\_\_  
**ABSENT FROM VOTING:** \_\_\_\_\_  
**ABSTAIN:** \_\_\_\_\_

**ATTEST:**

\_\_\_\_\_  
Toushi Arbitelle, City Clerk

As the City Clerk of the City of Leeds, I hereby certify that the above Ordinance was duly adopted by the City Council of the City of Leeds at a special called meeting held on the 6th day of January 2020

\_\_\_\_\_  
City Clerk

**Item Attachment Documents:**

17. Resolution 2019-12-02 (Carried over from the canceled meeting - December 16, 2019) Consider Adoption and Ratification of Monthly City Expenditures/Payables

# CITY OF LEEDS

## RESOLUTION NO.: 2019-12-02

### RESOLUTION IN ADOPTION AND RATIFICATION OF MONTHLY CITY PAYABLES/EXPENITURES

**WHEREAS**, although the Council approves a City budget and the related expenditures on an annual basis, the Council also has made it a practice to review and to ratify those expenditures; and

**WHEREAS**, in order to improve accountability and transparency, the Finance Committee has recommended that the review and ratification procedure occur on a monthly basis; and

**WHEREAS**, the City staff and the City Council has considered the attached monthly City expenditures and considers the approval and/or the ratification of those items to be just, authorized, and in the best interest of the City.

**NOW THEREFORE, BE IT RESOLVED**, by the City Council of the City of Leeds that:

1. The Recitals above are true, correct and included herein as if fully set forth.
2. The attached list of City expenditures is hereby ratified and approved for the month ending November 30, 2019.
3. The Mayor and staff shall have the full authority to do those things, perform those functions, make such decisions, and to sign necessary documentation in order to carry out and fully complete the actions so authorized herein.

**ADOPTED and APPROVED** at a regular meeting of the City Council of the City of Leeds, Alabama on this the 6<sup>th</sup> day of January 2020

**CITY OF LEEDS, ALABAMA**

\_\_\_\_\_  
David Miller, Mayor

\_\_\_\_\_  
DATE

**ATTEST:**

**AYES:** \_\_\_\_\_

**NAYS:** \_\_\_\_\_

**ABSENT:** \_\_\_\_\_

**ABSTAIN:** \_\_\_\_\_

\_\_\_\_\_  
Toushi Arbitelle, City Clerk

In my capacity as the City Clerk of the City of Leeds, hereby certify that the above Resolution was duly adopted by the City Council of the City of Leeds at a regular meeting held on the 6th day of January 2020

\_\_\_\_\_  
City Clerk

## City of Leeds - General Fund

## EXPENSE DETAIL

November 2019

DATE	TRANSACTION TYPE	NAME	MEMO/DESCRIPTION	SPLIT	AMOUNT	BALANCE
01-4000 Admin Exp						
01-4001 Salaries & Wages						
						17,157.10
						Beginning Balance
11/08/2019	Expense	PBS		00-1122 General Fund Checking Accounts:Payroll Acct-Servis 1st-1427	8,373.82	25,530.92
11/22/2019	Expense	PBS		00-1122 General Fund Checking Accounts:Payroll Acct-Servis 1st-1427	8,539.96	34,070.88
<b>Total for 01-4001 Salaries &amp; Wages</b>					<b>\$16,913.78</b>	
01-4002 Payroll Taxes						
						1,239.43
						Beginning Balance
11/08/2019	Expense	PBS		00-1122 General Fund Checking Accounts:Payroll Acct-Servis 1st-1427	603.86	1,843.29
11/22/2019	Expense	PBS		00-1122 General Fund Checking Accounts:Payroll Acct-Servis 1st-1427	616.72	2,460.01
<b>Total for 01-4002 Payroll Taxes</b>					<b>\$1,220.58</b>	
01-4004 Health Insurance						
						1,374.00
						Beginning Balance
11/08/2019	Expense	PBS		00-1122 General Fund Checking Accounts:Payroll Acct-Servis 1st-1427	-343.50	1,030.50
11/15/2019	Bill	2601-LOCAL GOVERNMENT HEALTH INSURANCE BOARD	ADMINISTRATION & REVENUE	00-2010 Accounts Payable	2,061.00	3,091.50
11/22/2019	Expense	PBS		00-1122 General Fund Checking Accounts:Payroll Acct-Servis 1st-1427	-343.50	2,748.00
<b>Total for 01-4004 Health Insurance</b>					<b>\$1,374.00</b>	
01-4005 Retiree Health Insurance Prem.						
						5,320.00
						Beginning Balance
11/15/2019	Bill	2601-LOCAL GOVERNMENT HEALTH INSURANCE BOARD	RETIREEES	00-2010 Accounts Payable	5,310.00	10,630.00
<b>Total for 01-4005 Retiree Health Insurance Prem.</b>					<b>\$5,310.00</b>	
01-4006 Retirement						
						2,273.09
						Beginning Balance
11/08/2019	Expense	851- Retirement Systems of Alabama		00-1114 General Fund Checking Accounts:Gen'l Fund-Servis 1st-4304	915.44	3,188.53
11/25/2019	Expense	851- Retirement Systems of Alabama		00-1114 General Fund Checking Accounts:Gen'l Fund-Servis 1st-4304	894.20	4,082.73
<b>Total for 01-4006 Retirement</b>					<b>\$1,809.64</b>	
01-4015 EE Life & Disability Ins						
						-13.83
						Beginning Balance
11/15/2019	Bill	2725a-MUTUAL OF OMAHA		00-2010 Accounts Payable	10.27	-3.56
11/15/2019	Bill	2725a-MUTUAL OF OMAHA		00-2010 Accounts Payable	15.98	12.42
11/30/2019	Bill	2725a-MUTUAL OF OMAHA		00-2010 Accounts Payable	16.63	29.05
11/30/2019	Bill	2725b-MUTUAL OF OMAHA		00-2010 Accounts Payable	10.27	39.32
11/30/2019	Bill	2725a-MUTUAL OF OMAHA		00-2010 Accounts Payable	10.27	49.59
11/30/2019	Bill	2725b-MUTUAL OF OMAHA		00-2010 Accounts Payable	15.98	65.57
11/30/2019	Bill	2725a-MUTUAL OF OMAHA		00-2010 Accounts Payable	15.98	81.55
<b>Total for 01-4015 EE Life &amp; Disability Ins</b>					<b>\$95.38</b>	
01-4100 Insurance - General						
						914.00
						Beginning Balance
11/15/2019	Bill	3119-CARD SERVICES (8365)		00-2010 Accounts Payable	100.00	1,014.00
<b>Total for 01-4100 Insurance - General</b>					<b>\$100.00</b>	
01-4200 Electrical Utilities						
						519.92
						Beginning Balance
11/15/2019	Bill	111-ALABAMA POWER		00-2010 Accounts Payable	394.22	914.14

DATE	TRANSACTION NAME	MEMO/DESCRIPTION	SPLIT	AMOUNT	BALANCE
85					
<b>Total for 01-4200 Electrical Utilities</b>				<b>\$394.22</b>	
01-4201 Internet					
Beginning Balance					
					5,978.80
11/15/2019	Bill	3119-CARD SERVICES (8365)	00-2010 Accounts Payable	1,760.00	7,738.80
11/15/2019	Bill	2997-UNITI FIBER /dba/ CONTACT NETWORK/INLINE	CITY HALL; PD/COURTS; DEVELOPMENT SERVICES; FD	4,218.80	11,957.60
<b>Total for 01-4201 Internet</b>				<b>\$5,978.80</b>	
01-4202 Telephone					
11/15/2019	Bill	3119-CARD SERVICES (8365)	00-2010 Accounts Payable	317.09	317.09
<b>Total for 01-4202 Telephone</b>				<b>\$317.09</b>	
01-4203 Cell / Wireless Services					
Beginning Balance					
					-40.11
11/05/2019	Sales Receipt	CITY OF LEEDS - GENERAL FUND	00-1299 Undeposited Funds	-40.11	-80.22
11/15/2019	Bill	3119-CARD SERVICES (8365)	00-2010 Accounts Payable	196.00	115.78
<b>Total for 01-4203 Cell / Wireless Services</b>				<b>\$155.89</b>	
01-4204 Gas Utilities					
Beginning Balance					
					30.89
11/15/2019	Bill	122-SPIRE INC	CITY HALL & RECORDS BLDG	31.24	62.13
11/30/2019	Bill	122-SPIRE INC	CITY HALL & RECORDS BLDG	46.31	108.44
<b>Total for 01-4204 Gas Utilities</b>				<b>\$77.55</b>	
01-4206 Water Utilities					
11/15/2019	Bill	3119-CARD SERVICES (8365)	00-2010 Accounts Payable	39.61	39.61
<b>Total for 01-4206 Water Utilities</b>				<b>\$39.61</b>	
01-4208 Sewer Utilities					
11/15/2019	Bill	3119-CARD SERVICES (8365)	00-2010 Accounts Payable	43.19	43.19
<b>Total for 01-4208 Sewer Utilities</b>				<b>\$43.19</b>	
01-4212 Storm Water Fee					
11/15/2019	Bill	3119-CARD SERVICES (8365)	00-2010 Accounts Payable	691.88	691.88
<b>Total for 01-4212 Storm Water Fee</b>				<b>\$691.88</b>	
01-4304 Copier & Printer Mtc					
11/15/2019	Bill	3119-CARD SERVICES (8365)	00-2010 Accounts Payable	183.16	183.16
<b>Total for 01-4304 Copier &amp; Printer Mtc</b>				<b>\$183.16</b>	
01-4306 Department Supplies					
11/15/2019	Bill	3119-CARD SERVICES (8365)	00-2010 Accounts Payable	4,331.94	4,331.94
<b>Total for 01-4306 Department Supplies</b>				<b>\$4,331.94</b>	
01-4308 PR Advertising					
11/15/2019	Bill	3119-CARD SERVICES (8365)	00-2010 Accounts Payable	118.80	118.80
<b>Total for 01-4308 PR Advertising</b>				<b>\$118.80</b>	
01-4314 Subscriptions					
Beginning Balance					
					9,434.38
11/15/2019	Bill	3119-CARD SERVICES (8365)	00-2010 Accounts Payable	906.43	10,340.81
11/15/2019	Bill	CORPORATE BUSINESS SOLUTIONS	75% OF DISCOUNTED IMPLEMENTATION FEE FOR PAYROLL/HRIS SERVICES	1,815.00	12,155.81
<b>Total for 01-4314 Subscriptions</b>				<b>\$2,721.43</b>	
01-4316 Dues & Fees					
Beginning Balance					
					794.50
11/08/2019	Expense	PBS	00-1122 General Fund Checking Accounts:Payroll Acct-Servis 1st-1427	296.25	1,090.75
11/22/2019	Expense	PBS	00-1122 General Fund Checking Accounts:Payroll Acct-Servis 1st-1427	525.75	1,616.50
<b>Total for 01-4316 Dues &amp; Fees</b>				<b>\$822.00</b>	
01-4320 Postage					
Beginning Balance					
					27.00
11/15/2019	Bill	3119-CARD SERVICES (8365)	00-2010 Accounts Payable	178.50	205.50
11/15/2019	Bill	PURCHASE POWER	ACCOUNT# 800-9090-1005-8498	75.00	280.50
<b>Total for 01-4320 Postage</b>				<b>\$253.50</b>	
01-4324 Computer Software					
Beginning Balance					
					1,400.00
11/15/2019	Bill	3119-CARD SERVICES (8365)	00-2010 Accounts Payable	311.56	1,711.56
<b>Total for 01-4324 Computer Software</b>				<b>\$311.56</b>	
01-4326 Computer Hardware					
11/15/2019	Bill	3119-CARD SERVICES (8365)	00-2010 Accounts Payable	436.49	436.49
11/30/2019	Bill	2687 CDW GOVERNMENT	INVOICE TWK0501	134.05	570.54

DATE	TRANSACTION NAME	MEMO/DESCRIPTION	SPLIT	AMOUNT	BALANCE
86					
<b>Total for 01-4326 Computer Hardware</b>				<b>\$570.54</b>	
01-4328 Server Support					
11/15/2019	Bill	3119-CARD SERVICES (8365)	00-2010 Accounts Payable	7,697.75	7,697.75
<b>Total for 01-4328 Server Support</b>				<b>\$7,697.75</b>	
01-4330 Education & Training					
11/15/2019	Bill	3119-CARD SERVICES (8365)	00-2010 Accounts Payable	855.00	855.00
<b>Total for 01-4330 Education &amp; Training</b>				<b>\$855.00</b>	
01-4332 Travel					
Beginning Balance					121.07
11/15/2019	Bill	3119-CARD SERVICES (8365)	00-2010 Accounts Payable	523.09	644.16
<b>Total for 01-4332 Travel</b>				<b>\$523.09</b>	
01-4400 Contract Services					
Beginning Balance					10,329.47
11/13/2019	Sales Receipt	STATE OF ALABAMA DEPARTMENT OF REVENUE	00-1299 Undeposited Funds	3,173.04	13,502.51
11/15/2019	Bill	2193-LANEY'S	OCT 2019 SR LUNCHES	1,840.00	15,342.51
11/15/2019	Bill	3119-CARD SERVICES (8365)	00-2010 Accounts Payable	1,302.26	16,644.77
11/30/2019	Bill	2193-LANEY'S	NOVEMBER LUNCHES	1,644.00	18,288.77
11/30/2019	Bill	1184-EMPLOYEE ASSISTANCE SERVICES	NOV 2019	253.00	18,541.77
<b>Total for 01-4400 Contract Services</b>				<b>\$8,212.30</b>	
01-4402 Attorney/Legal					
Beginning Balance					21,400.00
11/15/2019	Bill	2823-BRUNSON, BARNETT & SHERRER PC	00-2010 Accounts Payable	20,780.00	42,180.00
<b>Total for 01-4402 Attorney/Legal</b>				<b>\$20,780.00</b>	
01-4404 Auditing/Accounting					
Beginning Balance					15,886.72
11/15/2019	Bill	1238-BMSS - BARFIELD MURPHY SHANK & SMITH	BALANCE OWED FROM AUG 2019 INVOICE	2,901.00	18,787.72
11/30/2019	Bill	1238-BMSS - BARFIELD MURPHY SHANK & SMITH		13,792.00	32,579.72
<b>Total for 01-4404 Auditing/Accounting</b>				<b>\$16,693.00</b>	
01-4500 Repair & Maint Auto					
Beginning Balance					42.99
11/15/2019	Bill	3119-CARD SERVICES (8365)	00-2010 Accounts Payable	47.23	90.22
<b>Total for 01-4500 Repair &amp; Maint Auto</b>				<b>\$47.23</b>	
01-4508 Repair & MTC - General					
Beginning Balance					225.00
11/15/2019	Bill	3119-CARD SERVICES (8365)	00-2010 Accounts Payable	2,897.91	3,122.91
11/15/2019	Bill	2219-CAUBLE ELECTRICAL CONTRACTOR INC	CITY HALL RECORDS ROOM	15,303.18	18,426.09
11/15/2019	Bill	319-TRI-COUNTY ROOFING & SIDING	REMOVED HVAC UNIT FROM ROOF & REPLACED METAL ROOFING PANELS	1,750.00	20,176.09
11/30/2019	Bill	2219-CAUBLE ELECTRICAL CONTRACTOR INC	CITY HALL FLAG LIGHT	368.00	20,544.09
<b>Total for 01-4508 Repair &amp; MTC - General</b>				<b>\$20,319.09</b>	
01-4520 Fuel Expense - Auto					
Beginning Balance					28.17
<b>Total for 01-4520 Fuel Expense - Auto</b>					
01-4702 Economic Redevelopment					
Beginning Balance					1,808.33
11/15/2019	Bill	597-LEEDS CHAMBER OF COMMERCE	00-2010 Accounts Payable	1,808.33	3,616.66
<b>Total for 01-4702 Economic Redevelopment</b>				<b>\$1,808.33</b>	
01-5011 City Prosecutor					
Beginning Balance					7,000.00
11/30/2019	Bill	2120-BARNES & BARNES LAW FIRM PC	PROSECUTOR & APPEALS	7,000.00	14,000.00
<b>Total for 01-5011 City Prosecutor</b>				<b>\$7,000.00</b>	
01-7720 772 Grant Agreement					
Beginning Balance					222,137.00
11/30/2019	Bill	ANN'S NEW LIFE CENTER	RESOLUTION 2019-11-01	2,500.00	224,637.00
<b>Total for 01-7720 772 Grant Agreement</b>				<b>\$2,500.00</b>	
<b>Total for 01-4000 Admin Exp</b>				<b>\$130,270.33</b>	
10-4000 Mayor					

DATE	TRANSACTION NAME	MEMO/DESCRIPTION	SPLIT	AMOUNT	BALANCE
87					
	10-4202 Mayor-Telephone				
	Beginning Balance				104.97
11/15/2019	Bill	3119-CARD SERVICES (8365)	00-2010 Accounts Payable	104.97	209.94
<b>Total for 10-4202 Mayor-Telephone</b>				<b>\$104.97</b>	
	10-4203 Mayor-Cell/Wireless Services				
11/15/2019	Bill	3119-CARD SERVICES (8365)	00-2010 Accounts Payable	154.58	154.58
<b>Total for 10-4203 Mayor-Cell/Wireless Services</b>				<b>\$154.58</b>	
	10-4300 Mayor-Office Supplies				
	Beginning Balance				16.19
11/15/2019	Bill	3119-CARD SERVICES (8365)	00-2010 Accounts Payable	35.12	51.31
<b>Total for 10-4300 Mayor-Office Supplies</b>				<b>\$35.12</b>	
	10-6702 Mayor-City Projects				
	Beginning Balance				2,500.00
<b>Total for 10-6702 Mayor-City Projects</b>					
<b>Total for 10-4000 Mayor</b>				<b>\$294.67</b>	
	11-4000 Court Exp				
	11-4001 Court-Salaries & Wages				
	Beginning Balance				12,272.24
11/08/2019	Expense	PBS	00-1122 General Fund Checking Accounts:Payroll Acct-Servis 1st-1427	5,556.17	17,828.41
11/22/2019	Expense	PBS	00-1122 General Fund Checking Accounts:Payroll Acct-Servis 1st-1427	6,513.42	24,341.83
<b>Total for 11-4001 Court-Salaries &amp; Wages</b>				<b>\$12,069.59</b>	
	11-4002 Court-Payroll Taxes				
	Beginning Balance				914.60
11/08/2019	Expense	PBS	00-1122 General Fund Checking Accounts:Payroll Acct-Servis 1st-1427	412.39	1,326.99
11/22/2019	Expense	PBS	00-1122 General Fund Checking Accounts:Payroll Acct-Servis 1st-1427	486.50	1,813.49
<b>Total for 11-4002 Court-Payroll Taxes</b>				<b>\$898.89</b>	
	11-4004 Court-Health Insurance				
	Beginning Balance				1,353.00
11/08/2019	Expense	PBS	00-1122 General Fund Checking Accounts:Payroll Acct-Servis 1st-1427	-15.00	1,338.00
11/15/2019	Bill	2601-LOCAL GOVERNMENT HEALTH INSURANCE BOARD	COURT 00-2010 Accounts Payable	1,383.00	2,721.00
11/22/2019	Expense	PBS	00-1122 General Fund Checking Accounts:Payroll Acct-Servis 1st-1427	-15.00	2,706.00
<b>Total for 11-4004 Court-Health Insurance</b>				<b>\$1,353.00</b>	
	11-4006 Court-Retirement				
	Beginning Balance				2,273.09
11/08/2019	Expense	851- Retirement Systems of Alabama	00-1114 General Fund Checking Accounts:Gen'l Fund-Servis 1st-4304	915.44	3,188.53
11/25/2019	Expense	851- Retirement Systems of Alabama	00-1114 General Fund Checking Accounts:Gen'l Fund-Servis 1st-4304	894.20	4,082.73
<b>Total for 11-4006 Court-Retirement</b>				<b>\$1,809.64</b>	
	11-4015 Court-EE Life & Disability Ins				
	Beginning Balance				45.86
11/15/2019	Bill	2725a-MUTUAL OF OMAHA	00-2010 Accounts Payable	22.93	68.79
11/30/2019	Bill	2725a-MUTUAL OF OMAHA	00-2010 Accounts Payable	22.93	91.72
11/30/2019	Bill	2725a-MUTUAL OF OMAHA	00-2010 Accounts Payable	16.63	108.35
11/30/2019	Bill	2725b-MUTUAL OF OMAHA	00-2010 Accounts Payable	22.93	131.28
<b>Total for 11-4015 Court-EE Life &amp; Disability Ins</b>				<b>\$85.42</b>	
	11-4200 Court-Electrical Utilities				
	Beginning Balance				1,182.26
11/15/2019	Bill	111-ALABAMA POWER	00-2010 Accounts Payable	865.84	2,048.10
<b>Total for 11-4200 Court-Electrical Utilities</b>				<b>\$865.84</b>	

DATE	TRANSACTION NAME	MEMO/DESCRIPTION	SPLIT	AMOUNT	BALANCE
88					
11-4202	Court-Telephone Expense				
11/15/2019	Bill 3119-CARD SERVICES (8365)		00-2010 Accounts Payable	148.25	148.25
<b>Total for 11-4202 Court-Telephone Expense</b>				<b>\$148.25</b>	
11-4203	Court-Cell / Wireless Services				
11/15/2019	Bill 3119-CARD SERVICES (8365)		00-2010 Accounts Payable	209.47	209.47
<b>Total for 11-4203 Court-Cell / Wireless Services</b>				<b>\$209.47</b>	
11-4204	Court-Gas Utilities				
Beginning Balance					14.15
11/15/2019	Bill 122-SPIRE INC	COURTS	00-2010 Accounts Payable	13.41	27.56
11/30/2019	Bill 122-SPIRE INC	COURT	00-2010 Accounts Payable	30.56	58.12
<b>Total for 11-4204 Court-Gas Utilities</b>				<b>\$43.97</b>	
11-4206	Court-Water Utilities				
11/15/2019	Bill 3119-CARD SERVICES (8365)		00-2010 Accounts Payable	44.26	44.26
<b>Total for 11-4206 Court-Water Utilities</b>				<b>\$44.26</b>	
11-4208	Court-Sewer Utilities				
11/15/2019	Bill 3119-CARD SERVICES (8365)		00-2010 Accounts Payable	69.72	69.72
<b>Total for 11-4208 Court-Sewer Utilities</b>				<b>\$69.72</b>	
11-4304	Court-Copier & Printer Mtc				
Beginning Balance					122.20
<b>Total for 11-4304 Court-Copier &amp; Printer Mtc</b>					
11-4306	Court-Department Supplies				
11/15/2019	Bill 3119-CARD SERVICES (8365)		00-2010 Accounts Payable	50.95	50.95
<b>Total for 11-4306 Court-Department Supplies</b>				<b>\$50.95</b>	
11-4316	Court-Dues & Fees				
11/15/2019	Bill 3119-CARD SERVICES (8365)		00-2010 Accounts Payable	34.34	34.34
<b>Total for 11-4316 Court-Dues &amp; Fees</b>				<b>\$34.34</b>	
11-4400	Court-Contract Services				
Beginning Balance					360.35
<b>Total for 11-4400 Court-Contract Services</b>					
11-4520	Court-Fuel Expense - Auto				
Beginning Balance					51.38
11/15/2019	Bill 3119-CARD SERVICES (8365)		00-2010 Accounts Payable	22.00	73.38
11/15/2019	Bill 3021-JOY MOMAN	MILEAGE FOR SEPT & OCT	00-2010 Accounts Payable	81.20	154.58
11/30/2019	Bill 1770-WEX BANK	COURT	00-2010 Accounts Payable	26.57	181.15
<b>Total for 11-4520 Court-Fuel Expense - Auto</b>				<b>\$129.77</b>	
11-5000	Court-Govt Agencies Monthly Report Fees				
11/15/2019	Bill 329-FINANCE DEPT-COMPTROLLER'S OFFICE	OCT 2019	00-2010 Accounts Payable	9,433.34	9,433.34
11/15/2019	Bill 1459-ST CLAIR COUNTY DISTRICT ATTORNEY'S OFFICE	OCT 2019-BAIL BOND FEES	00-2010 Accounts Payable	98.32	9,531.66
11/15/2019	Bill 1201-JEFFERSON COUNTY DISTRICT ATTORNEY'S OFFICE	OCT 2019 BAIL BOND FEES	00-2010 Accounts Payable	94.50	9,626.16
11/15/2019	Bill 1459-ST CLAIR COUNTY DISTRICT ATTORNEY'S OFFICE	OCT 2019 SOLICITOR FUND	00-2010 Accounts Payable	52.47	9,678.63
11/15/2019	Bill 2038-CIRCUIT CLERKS' JUDICIAL ADMINISTRATION FUND JEFF CO	OCT 2019	00-2010 Accounts Payable	334.94	10,013.57
11/15/2019	Bill 2040-CIRCUIT CLERKS' JUDICIAL ADMIN FUND ST CLAIR CO	OCT 2019	00-2010 Accounts Payable	12.33	10,025.90
11/15/2019	Bill 2042-PRESIDING CIRCUIT JUDGES' JUDICIAL ADMIN FUND ST CLAIR	OCT 2019	00-2010 Accounts Payable	12.33	10,038.23
11/15/2019	Bill 2041-PRESIDING CIRCUIT JUDGES' JUDICIAL ADMIN FUND JEFF CO	OCT 2019	00-2010 Accounts Payable	329.94	10,368.17
11/15/2019	Bill 1201-JEFFERSON COUNTY DISTRICT ATTORNEY'S OFFICE	OCT 2019 SOLICITOR FUND	00-2010 Accounts Payable	2,142.50	12,510.67
11/15/2019	Bill 2119-STONE LAW FIRM	OCT 2019 PUBLIC DEFENDER	00-2010 Accounts Payable	2,405.00	14,915.67
11/15/2019	Bill 109-ALABAMA PEACE OFFICERS ANNUITY & BENEFIT FUND	OCT 2019	00-2010 Accounts Payable	850.00	15,765.67
11/15/2019	Bill 95-ALABAMA CRIME VICTIMS COMPENSATION COMMISSION	OCT 2019	00-2010 Accounts Payable	531.00	16,296.67
11/15/2019	Bill 1404- CITIZENSHIP TRUST FUND	OCT 2019	00-2010 Accounts Payable	150.00	16,446.67
11/15/2019	Bill 2020-STATE JUDICIAL ADMIN FUND	OCT 2019	00-2010 Accounts Payable	1,440.12	17,886.79
11/15/2019	Bill 3085-ALABAMA LAW ENFORCEMENT AGENCY (ALEA)	OCT 2019-HIGHWAY TRAFFIC SAFETY FUND	00-2010 Accounts Payable	60.00	17,946.79
11/15/2019	Bill 3085-ALABAMA LAW ENFORCEMENT AGENCY (ALEA)	OCT 2019-ALABAMA INTERLOCK INDIGENT FUND	00-2010 Accounts Payable	34.00	17,980.79
<b>Total for 11-5000 Court-Govt Agencies Monthly Report Fees</b>				<b>\$17,980.79</b>	
11-5002	Court-Restitution				
11/15/2019	Bill PAULETTE PAYNE	MC18-730	00-2010 Accounts Payable	200.00	200.00
<b>Total for 11-5002 Court-Restitution</b>				<b>\$200.00</b>	



DATE	TRANSACTION NAME	MEMO/DESCRIPTION	SPLIT	AMOUNT	BALANCE
89					
11-5010	Court-Municipal Judge				
	Beginning Balance				2,500.00
11/30/2019	Bill 2943-CLIFTON S PRICE, III	NOV 2019	00-2010 Accounts Payable	2,500.00	5,000.00
<b>Total for 11-5010 Court-Municipal Judge</b>				<b>\$2,500.00</b>	
11-6998	Court to Court Transfer				
11/15/2019	Bill REGIONS-LEEDS MUNICIPAL COURT CORRECTIONS	OCT 2019: COPY, CORRECTIONS FUND, MONITORING FEE, WARRANT RECALL FEE, WRIT FEE	00-2010 Accounts Payable	7,198.32	7,198.32
11/15/2019	Bill REGIONS-LEEDS MUNICIPAL JUDICIAL ADMINISTRATIVE FUND	OCT 2019 TRANSFERS	00-2010 Accounts Payable	1,835.86	9,034.18
11/15/2019	Bill REGIONS-LEEDS MUNICIPAL COURT MAGISTRATE TRAINING & EDUCATION FUND	OCT 2019	00-2010 Accounts Payable	307.50	9,341.68
<b>Total for 11-6998 Court to Court Transfer</b>				<b>\$9,341.68</b>	
11-6999	Court to GF Transfer				
	Beginning Balance				-32,904.33
11/15/2019	Bill 66-CITY OF LEEDS - GENERAL FUND	OCT 2019 COLLECTIONS	00-2010 Accounts Payable	26,746.00	-6,158.33
<b>Total for 11-6999 Court to GF Transfer</b>				<b>\$26,746.00</b>	
<b>Total for 11-4000 Court Exp</b>				<b>\$74,581.58</b>	
12-4000	Cemetery Exp				
11/30/2019	Bill 1503-RAM LANDSCAPING	SHILOH CEMETERY 11/18/2019 - 11/25/2019	00-2010 Accounts Payable	550.00	550.00
11/30/2019	Bill 1503-RAM LANDSCAPING	CEDAR GROVE CEMETERY 11/19/2019 - 11/26/2019	00-2010 Accounts Payable	1,980.00	2,530.00
<b>Total for 12-4000 Cemetery Exp</b>				<b>\$2,530.00</b>	
12-4206	Cemetery-Water Utilities				
11/15/2019	Bill 3119-CARD SERVICES (8365)		00-2010 Accounts Payable	90.06	90.06
<b>Total for 12-4206 Cemetery-Water Utilities</b>				<b>\$90.06</b>	
12-4306	Cemetery-Department Supplies				
11/15/2019	Bill 3119-CARD SERVICES (8365)		00-2010 Accounts Payable	47.76	47.76
<b>Total for 12-4306 Cemetery-Department Supplies</b>				<b>\$47.76</b>	
12-4400	Cemetery-Contract Services				
	Beginning Balance				7,530.00
11/15/2019	Bill 1503-RAM LANDSCAPING	SHILOH	00-2010 Accounts Payable	825.00	8,355.00
11/15/2019	Bill 1503-RAM LANDSCAPING	CEDAR GROVE	00-2010 Accounts Payable	2,940.00	11,295.00
<b>Total for 12-4400 Cemetery-Contract Services</b>				<b>\$3,765.00</b>	
<b>Total for 12-4000 Cemetery Exp with subs</b>				<b>\$6,432.82</b>	
13-4000	Council				
13-4001	Council-Salaries & Wages				
	Beginning Balance				6,050.00
<b>Total for 13-4001 Council-Salaries &amp; Wages</b>					
13-4002	Council-Payroll Taxes				
	Beginning Balance				468.28
<b>Total for 13-4002 Council-Payroll Taxes</b>					
<b>Total for 13-4000 Council</b>					
16-4000	Sr Citizens				
16-4306	Sr Citizens-Department Supplies				
	Beginning Balance				25.92
11/15/2019	Bill 163-ALINDA YARBROUGH	WAL-MART	00-2010 Accounts Payable	70.36	96.28
<b>Total for 16-4306 Sr Citizens-Department Supplies</b>				<b>\$70.36</b>	
16-4400	Sr Citizens-Contract Services				
	Beginning Balance				440.00
11/15/2019	Bill 2710-PAUL ZUCKERMAN	OCTOBER EXERCISE	00-2010 Accounts Payable	400.00	840.00
11/15/2019	Bill 3149-PATRICIA KELLY		00-2010 Accounts Payable	80.00	920.00
11/30/2019	Bill 2710-PAUL ZUCKERMAN	NOVEMBER CLASS	00-2010 Accounts Payable	480.00	1,400.00
<b>Total for 16-4400 Sr Citizens-Contract Services</b>				<b>\$960.00</b>	
<b>Total for 16-4000 Sr Citizens</b>				<b>\$1,030.36</b>	
19-4000	City Projects				
19-6102	Parks & Paving-City Projects				
	Beginning Balance				237,389.00
<b>Total for 19-6102 Parks &amp; Paving-City Projects</b>					
19-6304	Hwy 78/Pres St-Engineering				
	Beginning Balance				12,306.25
11/15/2019	Bill 389-GOODWYN, MILLS & CAWOOD INC	ALDOT PROJECT NO. STPAA-0004(543) US 78 IMPROVEMENTS FROM PRESIDENT ST TO PARK DR	00-2010 Accounts Payable	22,334.25	34,640.50

DATE	TRANSACTION TYPE	NAME	MEMO/DESCRIPTION	SPLIT	AMOUNT	BALANCE
11/30/2019	Bill	389-GOODWYN, MILLS & CAWOOD INC	CBHM160054 LEEDS HWY 78 DRIVE TRAFFIC SIGNAL WARRANT STUDY	00-2010 Accounts Payable	2,000.00	36,640.50
11/30/2019	Bill	389-GOODWYN, MILLS & CAWOOD INC	CBHM160055 LEEDS PRESIDENT STREET TRAFFIC SIGNAL WARRANT STUDY DESIGN	00-2010 Accounts Payable	2,000.00	38,640.50
<b>Total for 19-6304 Hwy 78/Pres St-Engineering</b>					<b>\$26,334.25</b>	
19-6702 Main St AI-City Projects						
Beginning Balance						9,660.21
11/15/2019	Bill	2513-LEEDS REDEVELOPMENT AUTHORITY	INVOICE 2019-800	00-2010 Accounts Payable	1,729.00	11,389.21
11/15/2019	Bill	2513-LEEDS REDEVELOPMENT AUTHORITY	INVOICE 2019-725	00-2010 Accounts Payable	1,987.50	13,376.71
11/15/2019	Bill	2513-LEEDS REDEVELOPMENT AUTHORITY		00-2010 Accounts Payable	1,650.00	15,026.71
11/15/2019	Bill	2513-LEEDS REDEVELOPMENT AUTHORITY		00-2010 Accounts Payable	660.00	15,686.71
11/15/2019	Bill	2513-LEEDS REDEVELOPMENT AUTHORITY		00-2010 Accounts Payable	900.00	16,586.71
11/15/2019	Bill	2513-LEEDS REDEVELOPMENT AUTHORITY	REIMBURSEMENT FOR 8347 RAILROAD AVE PARKING LOT PROJECT-PHASE II	00-2010 Accounts Payable	18,011.25	34,597.96
11/15/2019	Bill	2513-LEEDS REDEVELOPMENT AUTHORITY	REIMBURSEMENT FOR 8052 PARKWAY DR PARKING LOT PROJECT-PHASE II	00-2010 Accounts Payable	19,051.25	53,649.21
11/15/2019	Bill	2513-LEEDS REDEVELOPMENT AUTHORITY	REIMBURSEMENT FOR 8347 RAILROAD AV PARKING LOT PROJECT-SITE PREPARATION	00-2010 Accounts Payable	25,468.75	79,117.96
11/15/2019	Bill	2513-LEEDS REDEVELOPMENT AUTHORITY	REIMBURSEMENT FOR 8052 PARKWAY DR PARKING LOT PROJECT-SITE PREPARATION	00-2010 Accounts Payable	28,191.76	107,309.72
11/15/2019	Bill	2513-LEEDS REDEVELOPMENT AUTHORITY	REIMBURSEMENT FOR 8347 RAILROAD AVE PARKING LOT PROJECT-LAND CLEARING/DEBRIS REMOVAL	00-2010 Accounts Payable	23,603.75	130,913.47
11/15/2019	Bill	2513-LEEDS REDEVELOPMENT AUTHORITY	REIMBURSEMENT FOR 8052 PARKWAY DR PARKING LOT PROJECT-LAND CLEARING/DEBRIS REMOVAL	00-2010 Accounts Payable	20,880.00	151,793.47
11/15/2019	Bill	2513-LEEDS REDEVELOPMENT AUTHORITY	REIMBURSEMENT-INVOICE 29808	00-2010 Accounts Payable	1,156.96	152,950.43
11/15/2019	Bill	2513-LEEDS REDEVELOPMENT AUTHORITY	REIMBURSEMENT-INVOICE 29685	00-2010 Accounts Payable	685.96	153,636.39
11/15/2019	Bill	2513-LEEDS REDEVELOPMENT AUTHORITY	REIMBURSEMENT-INVOICE 29618	00-2010 Accounts Payable	887.69	154,524.08
11/15/2019	Bill	2513-LEEDS REDEVELOPMENT AUTHORITY	REIMBURSEMENT-INVOICE 29599	00-2010 Accounts Payable	225.04	154,749.12
11/15/2019	Bill	2513-LEEDS REDEVELOPMENT AUTHORITY	REIMBURSEMENT-INVOICE 29590	00-2010 Accounts Payable	1,203.32	155,952.44
11/15/2019	Bill	2513-LEEDS REDEVELOPMENT AUTHORITY	REIMBURSEMENT-INVOICE 29547	00-2010 Accounts Payable	230.58	156,183.02
11/15/2019	Bill	2513-LEEDS REDEVELOPMENT AUTHORITY	REIMBURSEMENT-INVOICE 29498	00-2010 Accounts Payable	1,165.39	157,348.41
11/15/2019	Bill	2513-LEEDS REDEVELOPMENT AUTHORITY	REIMBURSEMENT-INVOICE 29393	00-2010 Accounts Payable	1,201.56	158,549.97
11/15/2019	Bill	2513-LEEDS REDEVELOPMENT AUTHORITY	REIMBURSEMENT-INVOICE 29269	00-2010 Accounts Payable	200.69	158,750.66
<b>Total for 19-6702 Main St AI-City Projects</b>					<b>\$149,090.45</b>	
<b>Total for 19-4000 City Projects</b>					<b>\$175,424.70</b>	
22-4000 Police Exp						
22-4001 Police-Salaries & Wages						
Beginning Balance						118,600.08
11/08/2019	Expense	PBS		00-1122 General Fund Checking Accounts:Payroll Acct-Servis 1st-1427	61,291.22	179,891.30
11/22/2019	Expense	PBS		00-1122 General Fund Checking Accounts:Payroll Acct-Servis 1st-1427	61,405.58	241,296.88
<b>Total for 22-4001 Police-Salaries &amp; Wages</b>					<b>\$122,696.80</b>	
22-4002 Police-Payroll Taxes						
Beginning Balance						8,847.48
11/08/2019	Expense	PBS		00-1122 General Fund Checking Accounts:Payroll Acct-Servis 1st-1427	4,577.84	13,425.32
11/22/2019	Expense	PBS		00-1122 General Fund Checking Accounts:Payroll Acct-Servis 1st-1427	4,586.70	18,012.02
<b>Total for 22-4002 Police-Payroll Taxes</b>					<b>\$9,164.54</b>	
22-4004 Police-Health Insurance						
Beginning Balance						15,949.00
11/08/2019	Expense	PBS		00-1122 General Fund Checking	-1,747.50	14,201.50

DATE	TRANSACTION TYPE	NAME	MEMO/DESCRIPTION	SPLIT	AMOUNT	BALANCE
91						
				Accounts:Payroll Acct-Servis 1st-1427		
11/15/2019	Bill	2601-LOCAL GOVERNMENT HEALTH INSURANCE BOARD	PD	00-2010 Accounts Payable	19,444.00	33,645.50
11/22/2019	Expense	PBS		00-1122 General Fund Checking	-1,747.50	31,898.00
				Accounts:Payroll Acct-Servis 1st-1427		
<b>Total for 22-4004 Police-Health Insurance</b>					<b>\$15,949.00</b>	
22-4006 Police-Retirement						
Beginning Balance						
						13,111.45
11/08/2019	Expense	851- Retirement Systems of Alabama		00-1114 General Fund Checking	7,347.00	20,458.45
				Accounts:Gen'l Fund-Servis 1st-4304		
11/25/2019	Expense	851- Retirement Systems of Alabama		00-1114 General Fund Checking	7,536.12	27,994.57
				Accounts:Gen'l Fund-Servis 1st-4304		
<b>Total for 22-4006 Police-Retirement</b>					<b>\$14,883.12</b>	
22-4012 Police-Uniforms						
Beginning Balance						
						881.93
11/15/2019	Bill	3119-CARD SERVICES (8365)		00-2010 Accounts Payable	254.76	1,136.69
<b>Total for 22-4012 Police-Uniforms</b>					<b>\$254.76</b>	
22-4014 Police-Other Benefits						
Beginning Balance						
						690.00
<b>Total for 22-4014 Police-Other Benefits</b>						
22-4015 Police-EE Life & Disability Ins						
Beginning Balance						
						436.92
11/15/2019	Bill	2725a-MUTUAL OF OMAHA		00-2010 Accounts Payable	235.31	672.23
11/30/2019	Bill	2725a-MUTUAL OF OMAHA		00-2010 Accounts Payable	235.31	907.54
11/30/2019	Bill	2725a-MUTUAL OF OMAHA		00-2010 Accounts Payable	16.63	924.17
11/30/2019	Bill	2725b-MUTUAL OF OMAHA		00-2010 Accounts Payable	235.31	1,159.48
<b>Total for 22-4015 Police-EE Life &amp; Disability Ins</b>					<b>\$722.56</b>	
22-4018 Police-Employment Expense						
Beginning Balance						
						50.00
11/15/2019	Bill	JESSE SPRAYBERRY	POLYGRAPH & INTERVIEW-JOSEPH DEWAYNE McLAUGHLIN	00-2010 Accounts Payable	150.00	200.00
11/15/2019	Bill	3119-CARD SERVICES (8365)		00-2010 Accounts Payable	540.00	740.00
11/15/2019	Bill	JESSE SPRAYBERRY	POLYGRAPH & INTERVIEW-NIYASMINE JALEXUS MORGAN	00-2010 Accounts Payable	150.00	890.00
<b>Total for 22-4018 Police-Employment Expense</b>					<b>\$840.00</b>	
22-4200 Police-Electrical Utilities						
Beginning Balance						
						1,182.26
11/15/2019	Bill	3119-CARD SERVICES (8365)		00-2010 Accounts Payable	134.21	1,316.47
11/15/2019	Bill	111-ALABAMA POWER		00-2010 Accounts Payable	865.85	2,182.32
<b>Total for 22-4200 Police-Electrical Utilities</b>					<b>\$1,000.06</b>	
22-4202 Police-Telephone						
11/15/2019	Bill	3119-CARD SERVICES (8365)		00-2010 Accounts Payable	618.93	618.93
<b>Total for 22-4202 Police-Telephone</b>					<b>\$618.93</b>	
22-4203 Police-Cell / Wireless Services						
11/15/2019	Bill	3119-CARD SERVICES (8365)		00-2010 Accounts Payable	1,034.42	1,034.42
<b>Total for 22-4203 Police-Cell / Wireless Services</b>					<b>\$1,034.42</b>	
22-4204 Police-Gas Utilities						
Beginning Balance						
						14.15
11/15/2019	Bill	122-SPIRE INC	PD	00-2010 Accounts Payable	13.41	27.56
11/15/2019	Bill	3119-CARD SERVICES (8365)		00-2010 Accounts Payable	8.52	36.08
11/30/2019	Bill	122-SPIRE INC	PD	00-2010 Accounts Payable	30.56	66.64
<b>Total for 22-4204 Police-Gas Utilities</b>					<b>\$52.49</b>	
22-4206 Police-Water Utilities						
11/15/2019	Bill	3119-CARD SERVICES (8365)		00-2010 Accounts Payable	44.26	44.26
<b>Total for 22-4206 Police-Water Utilities</b>					<b>\$44.26</b>	
22-4208 Police-Sewer Utilities						
11/15/2019	Bill	3119-CARD SERVICES (8365)		00-2010 Accounts Payable	69.72	69.72
<b>Total for 22-4208 Police-Sewer Utilities</b>					<b>\$69.72</b>	
22-4300 Police-Office Supplies						
11/15/2019	Bill	3119-CARD SERVICES (8365)		00-2010 Accounts Payable	145.78	145.78
<b>Total for 22-4300 Police-Office Supplies</b>					<b>\$145.78</b>	
22-4304 Police-Copier & Printer Mtc						

DATE	TRANSACTION TYPE	NAME	MEMO/DESCRIPTION	SPLIT	AMOUNT	BALANCE
11/15/2019	Bill	3119-CARD SERVICES (8365)		00-2010 Accounts Payable	163.77	163.77
<b>Total for 22-4304 Police-Copier &amp; Printer Mtc</b>					<b>\$163.77</b>	
22-4306 Police-Department Supplies						
11/15/2019	Bill	3119-CARD SERVICES (8365)		00-2010 Accounts Payable	597.98	597.98
<b>Total for 22-4306 Police-Department Supplies</b>					<b>\$597.98</b>	
22-4314 Police-Subscriptions						
Beginning Balance						690.00
11/15/2019	Bill	3119-CARD SERVICES (8365)		00-2010 Accounts Payable	2,980.00	3,670.00
<b>Total for 22-4314 Police-Subscriptions</b>					<b>\$2,980.00</b>	
22-4332 Police-Travel						
11/15/2019	Bill	3119-CARD SERVICES (8365)		00-2010 Accounts Payable	20.00	20.00
11/15/2019	Bill	MARK STILTS	MILEAGE (118 MILES) FOR DRAGER RECERT CLASS @ JSU (ANNISTON) ON 11/05/2019	00-2010 Accounts Payable	68.44	88.44
<b>Total for 22-4332 Police-Travel</b>					<b>\$88.44</b>	
22-4400 Police-Contract Services						
Beginning Balance						1,412.01
<b>Total for 22-4400 Police-Contract Services</b>						
22-4412 Police-Community Program						
Beginning Balance						4,262.69
<b>Total for 22-4412 Police-Community Program</b>						
22-4420 Police-Jail Expense						
11/15/2019	Bill	2649-ST CLAIR COUNTY JAIL	OCT 2019 JAIL REPORT	00-2010 Accounts Payable	10,042.50	10,042.50
<b>Total for 22-4420 Police-Jail Expense</b>					<b>\$10,042.50</b>	
22-4500 Police-Repair & Maint Auto						
Beginning Balance						118.99
11/05/2019	Journal Entry		2019 payout	-Split-	-1,226.26	-1,107.27
11/15/2019	Bill	3119-CARD SERVICES (8365)		00-2010 Accounts Payable	2,515.94	1,408.67
<b>Total for 22-4500 Police-Repair &amp; Maint Auto</b>					<b>\$1,289.68</b>	
22-4508 Police-Repair & MTC - Buildings						
11/15/2019	Bill	3119-CARD SERVICES (8365)		00-2010 Accounts Payable	31.75	31.75
<b>Total for 22-4508 Police-Repair &amp; MTC - Buildings</b>					<b>\$31.75</b>	
22-4514 Police-Firing Range						
11/15/2019	Bill	3119-CARD SERVICES (8365)		00-2010 Accounts Payable	2,000.00	2,000.00
<b>Total for 22-4514 Police-Firing Range</b>					<b>\$2,000.00</b>	
22-4520 Police-Fuel Expense - Auto						
Beginning Balance						4,763.62
11/30/2019	Bill	1770-WEX BANK	PD	00-2010 Accounts Payable	4,445.96	9,209.58
<b>Total for 22-4520 Police-Fuel Expense - Auto</b>					<b>\$4,445.96</b>	
<b>Total for 22-4000 Police Exp</b>					<b>\$189,116.52</b>	
26-4000 Fire Exp						
26-4001 Fire-Salaries & Wages						
Beginning Balance						112,195.37
11/08/2019	Expense	PBS		00-1122 General Fund Checking Accounts:Payroll Acct-Servis 1st-1427	57,677.33	169,872.70
11/22/2019	Expense	PBS		00-1122 General Fund Checking Accounts:Payroll Acct-Servis 1st-1427	60,003.14	229,875.84
<b>Total for 26-4001 Fire-Salaries &amp; Wages</b>					<b>\$117,680.47</b>	
26-4002 Fire-Payroll Taxes						
Beginning Balance						8,173.64
11/08/2019	Expense	PBS		00-1122 General Fund Checking Accounts:Payroll Acct-Servis 1st-1427	4,208.76	12,382.40
11/22/2019	Expense	PBS		00-1122 General Fund Checking Accounts:Payroll Acct-Servis 1st-1427	4,388.78	16,771.18
<b>Total for 26-4002 Fire-Payroll Taxes</b>					<b>\$8,597.54</b>	
26-4004 Fire-Health Insurance						
Beginning Balance						17,571.00
11/08/2019	Expense	PBS		00-1122 General Fund Checking Accounts:Payroll Acct-Servis 1st-1427	-2,449.50	15,121.50
11/15/2019	Bill	2601-LOCAL GOVERNMENT HEALTH INSURANCE BOARD	FD	00-2010 Accounts Payable	24,992.00	40,113.50

DATE	TRANSACTION TYPE	NAME	MEMO/DESCRIPTION	SPLIT	AMOUNT	BALANCE
11/22/2019	Expense	PBS		00-1122 General Fund Checking Accounts:Payroll Acct-Servis 1st-1427	-2,449.50	37,664.00
<b>Total for 26-4004 Fire-Health Insurance</b>					<b>\$20,093.00</b>	
26-4006 Fire-Retirement						
Beginning Balance						
						13,111.44
11/08/2019	Expense	851- Retirement Systems of Alabama		00-1114 General Fund Checking Accounts:Gen'l Fund-Servis 1st-4304	7,347.00	20,458.44
11/25/2019	Expense	851- Retirement Systems of Alabama		00-1114 General Fund Checking Accounts:Gen'l Fund-Servis 1st-4304	7,536.12	27,994.56
<b>Total for 26-4006 Fire-Retirement</b>					<b>\$14,883.12</b>	
26-4012 Fire-Uniforms						
11/15/2019	Bill	3119-CARD SERVICES (8365)		00-2010 Accounts Payable	273.41	273.41
<b>Total for 26-4012 Fire-Uniforms</b>					<b>\$273.41</b>	
26-4015 Fire-EE Life & Disability Ins						
Beginning Balance						
						601.70
11/15/2019	Bill	2725a-MUTUAL OF OMAHA		00-2010 Accounts Payable	209.81	811.51
11/30/2019	Bill	2725b-MUTUAL OF OMAHA		00-2010 Accounts Payable	241.71	1,053.22
11/30/2019	Bill	2725a-MUTUAL OF OMAHA		00-2010 Accounts Payable	218.60	1,271.82
11/30/2019	Bill	2725a-MUTUAL OF OMAHA		00-2010 Accounts Payable	16.63	1,288.45
<b>Total for 26-4015 Fire-EE Life &amp; Disability Ins</b>					<b>\$686.75</b>	
26-4018 Fire-Employment Expense						
Beginning Balance						
						130.00
11/15/2019	Bill	3119-CARD SERVICES (8365)		00-2010 Accounts Payable	8.72	138.72
11/30/2019	Bill	2106-ST VINCENTS OCCUPATIONAL		00-2010 Accounts Payable	46.00	184.72
<b>Total for 26-4018 Fire-Employment Expense</b>					<b>\$54.72</b>	
26-4200 Fire-Electrical Utilities						
Beginning Balance						
						2,287.87
11/15/2019	Bill	3119-CARD SERVICES (8365)		00-2010 Accounts Payable	134.20	2,422.07
11/15/2019	Bill	111-ALABAMA POWER		00-2010 Accounts Payable	1,665.35	4,087.42
<b>Total for 26-4200 Fire-Electrical Utilities</b>					<b>\$1,799.55</b>	
26-4202 Fire-Cell / Wireless Services						
11/15/2019	Bill	3119-CARD SERVICES (8365)		00-2010 Accounts Payable	369.13	369.13
<b>Total for 26-4202 Fire-Cell / Wireless Services</b>					<b>\$369.13</b>	
26-4203 Fire-Telephone						
11/15/2019	Bill	3119-CARD SERVICES (8365)		00-2010 Accounts Payable	247.12	247.12
<b>Total for 26-4203 Fire-Telephone</b>					<b>\$247.12</b>	
26-4204 Fire-Gas Utilities						
Beginning Balance						
						129.99
11/15/2019	Bill	122-SPIRE INC	FD	00-2010 Accounts Payable	128.44	258.43
11/15/2019	Bill	3119-CARD SERVICES (8365)		00-2010 Accounts Payable	8.52	266.95
11/30/2019	Bill	122-SPIRE INC	STATION 1, STATION 2 & LANE DRIVE STATION	00-2010 Accounts Payable	693.68	960.63
<b>Total for 26-4204 Fire-Gas Utilities</b>					<b>\$830.64</b>	
26-4206 Fire-Water Utilities						
11/15/2019	Bill	3119-CARD SERVICES (8365)		00-2010 Accounts Payable	199.31	199.31
<b>Total for 26-4206 Fire-Water Utilities</b>					<b>\$199.31</b>	
26-4208 Fire-Sewer Utilites						
11/15/2019	Bill	3119-CARD SERVICES (8365)		00-2010 Accounts Payable	152.76	152.76
<b>Total for 26-4208 Fire-Sewer Utilites</b>					<b>\$152.76</b>	
26-4306 Fire-Department Supplies						
Beginning Balance						
						313.58
11/15/2019	Bill	3119-CARD SERVICES (8365)		00-2010 Accounts Payable	719.97	1,033.55
<b>Total for 26-4306 Fire-Department Supplies</b>					<b>\$719.97</b>	
26-4316 Fire-Dues & Fees						
11/15/2019	Bill	3119-CARD SERVICES (8365)		00-2010 Accounts Payable	865.00	865.00
<b>Total for 26-4316 Fire-Dues &amp; Fees</b>					<b>\$865.00</b>	
26-4330 Fire-Education & Training						
Beginning Balance						
						4,120.00
11/15/2019	Bill	3119-CARD SERVICES (8365)		00-2010 Accounts Payable	1,504.96	5,624.96
<b>Total for 26-4330 Fire-Education &amp; Training</b>					<b>\$1,504.96</b>	
26-4332 Fire-Travel						
11/15/2019	Bill	3119-CARD SERVICES (8365)		00-2010 Accounts Payable	36.00	36.00
<b>Total for 26-4332 Fire-Travel</b>					<b>\$36.00</b>	

DATE	TRANSACTION NAME	MEMO/DESCRIPTION	SPLIT	AMOUNT	BALANCE
94					
	26-4400 Fire-Contract Services				
	Beginning Balance				5,369.02
11/15/2019	Bill	3119-CARD SERVICES (8365)	00-2010 Accounts Payable	96.08	5,465.10
	<b>Total for 26-4400 Fire-Contract Services</b>			<b>\$96.08</b>	
	26-4412 Fire-Community Programs				
11/15/2019	Bill	3119-CARD SERVICES (8365)	00-2010 Accounts Payable	107.96	107.96
	<b>Total for 26-4412 Fire-Community Programs</b>			<b>\$107.96</b>	
	26-4500 Fire-Repair & Maint Auto				
	Beginning Balance				39.79
11/15/2019	Bill	SOUTHERN VINTAGE FIRE APPARATUS ASSOC (SVFAA)	00-2010 Accounts Payable	1,200.00	1,239.79
11/15/2019	Bill	3119-CARD SERVICES (8365)	00-2010 Accounts Payable	4,802.85	6,042.64
	<b>Total for 26-4500 Fire-Repair &amp; Maint Auto</b>			<b>\$6,002.85</b>	
	26-4508 Fire-Repair & MTC - Building				
	Beginning Balance				88.93
11/15/2019	Bill	3119-CARD SERVICES (8365)	00-2010 Accounts Payable	419.17	508.10
	<b>Total for 26-4508 Fire-Repair &amp; MTC - Building</b>			<b>\$419.17</b>	
	26-4520 Fire-Fuel Expense - Auto				
	Beginning Balance				2,254.20
11/15/2019	Bill	3119-CARD SERVICES (8365)	00-2010 Accounts Payable	28.60	2,282.80
11/30/2019	Bill	1770-WEX BANK	FD 00-2010 Accounts Payable	2,106.72	4,389.52
	<b>Total for 26-4520 Fire-Fuel Expense - Auto</b>			<b>\$2,135.32</b>	
	26-4530 Fire-Department Tools				
	Beginning Balance				551.34
11/15/2019	Bill	3119-CARD SERVICES (8365)	00-2010 Accounts Payable	39.97	591.31
	<b>Total for 26-4530 Fire-Department Tools</b>			<b>\$39.97</b>	
	26-4540 Fire-Medical Supplies				
	Beginning Balance				148.30
11/15/2019	Bill	3119-CARD SERVICES (8365)	00-2010 Accounts Payable	5,007.30	5,155.60
	<b>Total for 26-4540 Fire-Medical Supplies</b>			<b>\$5,007.30</b>	
	26-4602 Fire-Rent - Fire Hydrants				
11/15/2019	Bill	3119-CARD SERVICES (8365)	00-2010 Accounts Payable	2,112.90	2,112.90
	<b>Total for 26-4602 Fire-Rent - Fire Hydrants</b>			<b>\$2,112.90</b>	
	<b>Total for 26-4000 Fire Exp</b>			<b>\$184,915.00</b>	
	33-4000 Depot				
	33-4200 Depot-Electrical Utilities				
	Beginning Balance				450.87
11/15/2019	Bill	111-ALABAMA POWER	00-2010 Accounts Payable	260.18	711.05
	<b>Total for 33-4200 Depot-Electrical Utilities</b>			<b>\$260.18</b>	
	33-4206 Depot-Water Utilities				
11/15/2019	Bill	3119-CARD SERVICES (8365)	00-2010 Accounts Payable	18.67	18.67
	<b>Total for 33-4206 Depot-Water Utilities</b>			<b>\$18.67</b>	
	<b>Total for 33-4000 Depot</b>			<b>\$278.85</b>	
	34-4000 Visitor's Center				
	34-4200 Visitor's Center-Electrical Utilities				
	Beginning Balance				331.26
11/15/2019	Bill	111-ALABAMA POWER	00-2010 Accounts Payable	95.36	426.62
	<b>Total for 34-4200 Visitor's Center-Electrical Utilities</b>			<b>\$95.36</b>	
	34-4204 Visitor's Center-Gas Utilities				
	Beginning Balance				14.39
11/15/2019	Bill	122-SPIRE INC	CHAMBER 00-2010 Accounts Payable	8.30	22.69
11/30/2019	Bill	122-SPIRE INC	CHAMBER 00-2010 Accounts Payable	61.84	84.53
	<b>Total for 34-4204 Visitor's Center-Gas Utilities</b>			<b>\$70.14</b>	
	34-4206 Visitor's Center-Water Utilities				
11/15/2019	Bill	3119-CARD SERVICES (8365)	00-2010 Accounts Payable	18.67	18.67
	<b>Total for 34-4206 Visitor's Center-Water Utilities</b>			<b>\$18.67</b>	
	34-4208 Visitor's Center-Sewer Utilities				
11/15/2019	Bill	3119-CARD SERVICES (8365)	00-2010 Accounts Payable	28.19	28.19
	<b>Total for 34-4208 Visitor's Center-Sewer Utilities</b>			<b>\$28.19</b>	
	34-4400 Visitor's Center-Contract Services				
	Beginning Balance				492.71

DATE	TRANSACTION NAME	MEMO/DESCRIPTION	SPLIT	AMOUNT	BALANCE
95					
<b>Total for 34-4400 Visitor's Center-Contract Services</b>					
34-4508 Visitor's Center-Repair & MTC - Building					
11/15/2019	Bill	1332-K&K CONSTRUCTION INC	00-2010 Accounts Payable	17,547.23	17,547.23
<b>Total for 34-4508 Visitor's Center-Repair &amp; MTC - Building</b>				<b>\$17,547.23</b>	
<b>Total for 34-4000 Visitor's Center</b>				<b>\$17,759.59</b>	
40-4000 Parks Exp					
40-4001 Parks-Salaries & Wages					
Beginning Balance					
					4,614.37
11/08/2019	Expense	PBS	00-1122 General Fund Checking Accounts:Payroll Acct-Servis 1st-1427	2,324.32	6,938.69
11/22/2019	Expense	PBS	00-1122 General Fund Checking Accounts:Payroll Acct-Servis 1st-1427	2,196.13	9,134.82
<b>Total for 40-4001 Parks-Salaries &amp; Wages</b>				<b>\$4,520.45</b>	
40-4002 Parks-Payroll Taxes					
Beginning Balance					
					357.16
11/08/2019	Expense	PBS	00-1122 General Fund Checking Accounts:Payroll Acct-Servis 1st-1427	179.90	537.06
11/22/2019	Expense	PBS	00-1122 General Fund Checking Accounts:Payroll Acct-Servis 1st-1427	169.98	707.04
<b>Total for 40-4002 Parks-Payroll Taxes</b>				<b>\$349.88</b>	
40-4006 Parks-Retirement					
Beginning Balance					
					2,273.09
11/08/2019	Expense	851- Retirement Systems of Alabama	00-1114 General Fund Checking Accounts:Gen'l Fund-Servis 1st-4304	915.44	3,188.53
11/25/2019	Expense	851- Retirement Systems of Alabama	00-1114 General Fund Checking Accounts:Gen'l Fund-Servis 1st-4304	894.20	4,082.73
<b>Total for 40-4006 Parks-Retirement</b>				<b>\$1,809.64</b>	
40-4015 Parks-Ee Life & Disability Ins					
Beginning Balance					
					17.46
11/15/2019	Bill	2725a-MUTUAL OF OMAHA	00-2010 Accounts Payable	8.73	26.19
11/30/2019	Bill	2725a-MUTUAL OF OMAHA	00-2010 Accounts Payable	16.63	42.82
11/30/2019	Bill	2725a-MUTUAL OF OMAHA	00-2010 Accounts Payable	8.73	51.55
11/30/2019	Bill	2725b-MUTUAL OF OMAHA	00-2010 Accounts Payable	8.73	60.28
<b>Total for 40-4015 Parks-Ee Life &amp; Disability Ins</b>				<b>\$42.82</b>	
40-4200 Parks-Electrical Utilities					
Beginning Balance					
					7,066.55
11/15/2019	Bill	111-ALABAMA POWER	00-2010 Accounts Payable	6,004.51	13,071.06
<b>Total for 40-4200 Parks-Electrical Utilities</b>				<b>\$6,004.51</b>	
40-4203 Parks-Telephone					
11/15/2019	Bill	3119-CARD SERVICES (8365)	00-2010 Accounts Payable	29.96	29.96
<b>Total for 40-4203 Parks-Telephone</b>				<b>\$29.96</b>	
40-4204 Parks-Gas Utilities					
Beginning Balance					
					66.33
11/15/2019	Bill	3119-CARD SERVICES (8365)	00-2010 Accounts Payable	53.35	119.68
11/15/2019	Bill	122-SPIRE INC	CIVIC CENTER	64.76	184.44
11/30/2019	Bill	122-SPIRE INC	CIVIC CENTER	221.04	405.48
<b>Total for 40-4204 Parks-Gas Utilities</b>				<b>\$339.15</b>	
40-4206 Parks-Water Utilites					
11/15/2019	Bill	3119-CARD SERVICES (8365)	00-2010 Accounts Payable	975.26	975.26
<b>Total for 40-4206 Parks-Water Utilites</b>				<b>\$975.26</b>	
40-4208 Parks-Sewer Utilites					
11/15/2019	Bill	3119-CARD SERVICES (8365)	00-2010 Accounts Payable	91.13	91.13
<b>Total for 40-4208 Parks-Sewer Utilites</b>				<b>\$91.13</b>	
40-4306 Parks-Department Supplies					
11/15/2019	Bill	3119-CARD SERVICES (8365)	00-2010 Accounts Payable	785.50	785.50
<b>Total for 40-4306 Parks-Department Supplies</b>				<b>\$785.50</b>	
40-4400 Parks-Contract Services					
Beginning Balance					
					6,382.21
11/15/2019	Bill	3119-CARD SERVICES (8365)	00-2010 Accounts Payable	1,234.00	7,616.21
<b>Total for 40-4400 Parks-Contract Services</b>				<b>\$1,234.00</b>	

DATE	TRANSACTION TYPE	NAME	MEMO/DESCRIPTION	SPLIT	AMOUNT	BALANCE
96						
40-4414 Parks-Downtown Beautification						
11/15/2019	Bill	3119-CARD SERVICES (8365)		00-2010 Accounts Payable	92.16	92.16
11/30/2019	Bill	ALABAMA POWER CO-JOINT USE & REVENUE REPORTING		00-2010 Accounts Payable	789.75	881.91
11/30/2019	Bill	2219-CAUBLE ELECTRICAL CONTRACTOR INC		00-2010 Accounts Payable	214.87	1,096.78
<b>Total for 40-4414 Parks-Downtown Beautification</b>					<b>\$1,096.78</b>	
40-4416 Parks-Tree Commission						
11/30/2019	Bill	2718-SITEONE LANDSCAPE SUPPLY LLC		00-2010 Accounts Payable	81.50	81.50
<b>Total for 40-4416 Parks-Tree Commission</b>					<b>\$81.50</b>	
40-4500 Parks-Repair & MTC - Auto						
11/30/2019	Bill	2219-CAUBLE ELECTRICAL CONTRACTOR INC		00-2010 Accounts Payable	50.00	50.00
<b>Total for 40-4500 Parks-Repair &amp; MTC - Auto</b>					<b>\$50.00</b>	
40-4508 Parks-Repair & MTC - Building						
11/15/2019	Bill	3119-CARD SERVICES (8365)		00-2010 Accounts Payable	220.48	220.48
<b>Total for 40-4508 Parks-Repair &amp; MTC - Building</b>					<b>\$220.48</b>	
<b>Total for 40-4000 Parks Exp</b>					<b>\$17,631.06</b>	
50-4000 Development Exp						
50-4001 Development-Salaries & Wages						
Beginning Balance						11,852.94
11/08/2019	Expense	PBS		00-1122 General Fund Checking Accounts:Payroll Acct-Servis 1st-1427	6,417.38	18,270.32
11/22/2019	Expense	PBS		00-1122 General Fund Checking Accounts:Payroll Acct-Servis 1st-1427	5,426.47	23,696.79
<b>Total for 50-4001 Development-Salaries &amp; Wages</b>					<b>\$11,843.85</b>	
50-4002 Development-Payroll Taxes						
Beginning Balance						884.73
11/08/2019	Expense	PBS		00-1122 General Fund Checking Accounts:Payroll Acct-Servis 1st-1427	480.36	1,365.09
11/22/2019	Expense	PBS		00-1122 General Fund Checking Accounts:Payroll Acct-Servis 1st-1427	403.67	1,768.76
<b>Total for 50-4002 Development-Payroll Taxes</b>					<b>\$884.03</b>	
50-4004 Development-Health Insurance						
Beginning Balance						1,717.50
11/08/2019	Expense	PBS		00-1122 General Fund Checking Accounts:Payroll Acct-Servis 1st-1427	-171.75	1,545.75
11/15/2019	Bill	2601-LOCAL GOVERNMENT HEALTH INSURANCE BOARD	DEVELOPMENT SERVICES	00-2010 Accounts Payable	2,061.00	3,606.75
11/22/2019	Expense	PBS		00-1122 General Fund Checking Accounts:Payroll Acct-Servis 1st-1427	-171.75	3,435.00
<b>Total for 50-4004 Development-Health Insurance</b>					<b>\$1,717.50</b>	
50-4006 Development-Retirement						
Beginning Balance						2,273.09
11/08/2019	Expense	851- Retirement Systems of Alabama		00-1114 General Fund Checking Accounts:Gen'l Fund-Servis 1st-4304	915.44	3,188.53
11/25/2019	Expense	851- Retirement Systems of Alabama		00-1114 General Fund Checking Accounts:Gen'l Fund-Servis 1st-4304	894.20	4,082.73
<b>Total for 50-4006 Development-Retirement</b>					<b>\$1,809.64</b>	
50-4012 Development-Uniforms						
11/15/2019	Bill	3119-CARD SERVICES (8365)		00-2010 Accounts Payable	492.89	492.89
<b>Total for 50-4012 Development-Uniforms</b>					<b>\$492.89</b>	
50-4015 Development-Ee Life & Disability Ins						
Beginning Balance						58.16
11/15/2019	Bill	2725a-MUTUAL OF OMAHA		00-2010 Accounts Payable	29.08	87.24
11/30/2019	Bill	2725b-MUTUAL OF OMAHA		00-2010 Accounts Payable	29.08	116.32
11/30/2019	Bill	2725a-MUTUAL OF OMAHA		00-2010 Accounts Payable	16.63	132.95
11/30/2019	Bill	2725a-MUTUAL OF OMAHA		00-2010 Accounts Payable	29.08	162.03
<b>Total for 50-4015 Development-Ee Life &amp; Disability Ins</b>					<b>\$103.87</b>	
50-4131 Development-Const. Ind. Craft Train						
11/15/2019	Bill	2930-CRAFT TRAINING FUND	APRIL 2019	00-2010 Accounts Payable	197.00	197.00



DATE	TRANSACTION TYPE	NAME	MEMO/DESCRIPTION	SPLIT	AMOUNT	BALANCE
97						
11/15/2019	Bill	2930-CRAFT TRAINING FUND	JUNE 2019	00-2010 Accounts Payable	157.00	354.00
11/15/2019	Bill	2930-CRAFT TRAINING FUND	AUGUST 2019	00-2010 Accounts Payable	678.00	1,032.00
11/15/2019	Bill	2930-CRAFT TRAINING FUND	JULY 2019	00-2010 Accounts Payable	4.00	1,036.00
11/15/2019	Bill	2930-CRAFT TRAINING FUND	SEPT 2019	00-2010 Accounts Payable	1.00	1,037.00
<b>Total for 50-4131 Development-Const. Ind. Craft Train</b>					<b>\$1,037.00</b>	
50-4200 Development-Electrical Utilities						
Beginning Balance						
						226.10
11/15/2019	Bill	111-ALABAMA POWER		00-2010 Accounts Payable	120.35	346.45
<b>Total for 50-4200 Development-Electrical Utilities</b>					<b>\$120.35</b>	
50-4202 Development-Telephone						
11/15/2019	Bill	3119-CARD SERVICES (8365)		00-2010 Accounts Payable	95.46	95.46
<b>Total for 50-4202 Development-Telephone</b>					<b>\$95.46</b>	
50-4203 Development-Cell / Wireless Services						
11/15/2019	Bill	3119-CARD SERVICES (8365)		00-2010 Accounts Payable	184.34	184.34
<b>Total for 50-4203 Development-Cell / Wireless Services</b>					<b>\$184.34</b>	
50-4206 Development-Water Utilities						
11/15/2019	Bill	3119-CARD SERVICES (8365)		00-2010 Accounts Payable	18.91	18.91
<b>Total for 50-4206 Development-Water Utilities</b>					<b>\$18.91</b>	
50-4208 Development-Sewer Utilities						
11/15/2019	Bill	3119-CARD SERVICES (8365)		00-2010 Accounts Payable	27.90	27.90
<b>Total for 50-4208 Development-Sewer Utilities</b>					<b>\$27.90</b>	
50-4300 Development-Office Supplies						
Beginning Balance						
						56.03
<b>Total for 50-4300 Development-Office Supplies</b>						
50-4303 Development-Copier & Printer Mtc						
11/15/2019	Bill	3119-CARD SERVICES (8365)		00-2010 Accounts Payable	312.94	312.94
<b>Total for 50-4303 Development-Copier &amp; Printer Mtc</b>					<b>\$312.94</b>	
50-4306 Development-Department Supplies						
11/15/2019	Bill	3119-CARD SERVICES (8365)		00-2010 Accounts Payable	6.49	6.49
11/30/2019	Bill	1053-THREADS INC		00-2010 Accounts Payable	60.00	66.49
<b>Total for 50-4306 Development-Department Supplies</b>					<b>\$66.49</b>	
50-4324 Development-Computer Software						
11/15/2019	Bill	3119-CARD SERVICES (8365)		00-2010 Accounts Payable	85.94	85.94
<b>Total for 50-4324 Development-Computer Software</b>					<b>\$85.94</b>	
50-4326 Development-Computer Hardware						
11/15/2019	Bill	3119-CARD SERVICES (8365)		00-2010 Accounts Payable	737.18	737.18
<b>Total for 50-4326 Development-Computer Hardware</b>					<b>\$737.18</b>	
50-4332 Development-Travel						
11/15/2019	Bill	3119-CARD SERVICES (8365)		00-2010 Accounts Payable	70.33	70.33
<b>Total for 50-4332 Development-Travel</b>					<b>\$70.33</b>	
50-4400 Development-Contract Services						
Beginning Balance						
						492.71
11/15/2019	Bill	3119-CARD SERVICES (8365)		00-2010 Accounts Payable	179.00	671.71
<b>Total for 50-4400 Development-Contract Services</b>					<b>\$179.00</b>	
50-4406 Development-Engineer Services						
Beginning Balance						
						919.67
<b>Total for 50-4406 Development-Engineer Services</b>						
50-4412 Development-Community Programs						
11/15/2019	Bill	3119-CARD SERVICES (8365)		00-2010 Accounts Payable	7,988.18	7,988.18
<b>Total for 50-4412 Development-Community Programs</b>					<b>\$7,988.18</b>	
50-4500 Development-Repair & Maint Auto						
11/15/2019	Bill	3119-CARD SERVICES (8365)		00-2010 Accounts Payable	519.78	519.78
<b>Total for 50-4500 Development-Repair &amp; Maint Auto</b>					<b>\$519.78</b>	
50-4520 Development-Fuel Expense - Auto						
Beginning Balance						
						257.37
11/30/2019	Bill	1770-WEX BANK	DEVELOPMENT SERVICES	00-2010 Accounts Payable	161.63	419.00
<b>Total for 50-4520 Development-Fuel Expense - Auto</b>					<b>\$161.63</b>	
50-6500 Development-Taxes & Recording Fees						
11/15/2019	Bill	3119-CARD SERVICES (8365)		00-2010 Accounts Payable	73.49	73.49
<b>Total for 50-6500 Development-Taxes &amp; Recording Fees</b>					<b>\$73.49</b>	
<b>Total for 50-4000 Development Exp</b>					<b>\$28,530.70</b>	
51-4000 Storm Water Exp						
51-4412 Storm Water - Community Programs						
11/15/2019	Bill	3119-CARD SERVICES (8365)		00-2010 Accounts Payable	301.00	301.00
<b>Total for 51-4412 Storm Water - Community Programs</b>					<b>\$301.00</b>	

DATE	TRANSACTION NAME TYPE	MEMO/DESCRIPTION	SPLIT	AMOUNT	BALANCE
98					
<b>Total for 51-4000 Storm Water Exp</b>				<b>\$301.00</b>	
70-4000 Library					
70-4001 Library-Salaries & Wages					
Beginning Balance					
					18,316.14
11/08/2019	Expense	PBS	00-1122 General Fund Checking Accounts:Payroll Acct-Servis 1st-1427	9,348.13	27,664.27
11/22/2019	Expense	PBS	00-1122 General Fund Checking Accounts:Payroll Acct-Servis 1st-1427	8,978.16	36,642.43
<b>Total for 70-4001 Library-Salaries &amp; Wages</b>				<b>\$18,326.29</b>	
70-4002 Library-Payroll Taxes					
Beginning Balance					
					1,382.43
11/08/2019	Expense	PBS	00-1122 General Fund Checking Accounts:Payroll Acct-Servis 1st-1427	705.91	2,088.34
11/22/2019	Expense	PBS	00-1122 General Fund Checking Accounts:Payroll Acct-Servis 1st-1427	677.29	2,765.63
<b>Total for 70-4002 Library-Payroll Taxes</b>				<b>\$1,383.20</b>	
70-4004 Library-Health Insurance					
Beginning Balance					
					2,609.50
11/08/2019	Expense	PBS	00-1122 General Fund Checking Accounts:Payroll Acct-Servis 1st-1427	-186.75	2,422.75
11/15/2019	Bill	2601-LOCAL GOVERNMENT HEALTH INSURANCE BOARD	LIBRARY	00-2010 Accounts Payable	2,983.00
11/22/2019	Expense	PBS	00-1122 General Fund Checking Accounts:Payroll Acct-Servis 1st-1427	-186.75	5,219.00
<b>Total for 70-4004 Library-Health Insurance</b>				<b>\$2,609.50</b>	
70-4006 Library-Retirement					
Beginning Balance					
					2,273.10
11/08/2019	Expense	851- Retirement Systems of Alabama	00-1114 General Fund Checking Accounts:Gen'l Fund-Servis 1st-4304	915.44	3,188.54
11/25/2019	Expense	851- Retirement Systems of Alabama	00-1114 General Fund Checking Accounts:Gen'l Fund-Servis 1st-4304	894.20	4,082.74
<b>Total for 70-4006 Library-Retirement</b>				<b>\$1,809.64</b>	
70-4015 Library-Ee Life & Disability Ins					
Beginning Balance					
					77.74
11/15/2019	Bill	2725a-MUTUAL OF OMAHA	00-2010 Accounts Payable	38.87	116.61
11/30/2019	Bill	2725a-MUTUAL OF OMAHA	00-2010 Accounts Payable	38.87	155.48
11/30/2019	Bill	2725a-MUTUAL OF OMAHA	00-2010 Accounts Payable	16.63	172.11
11/30/2019	Bill	2725b-MUTUAL OF OMAHA	00-2010 Accounts Payable	38.87	210.98
<b>Total for 70-4015 Library-Ee Life &amp; Disability Ins</b>				<b>\$133.24</b>	
70-4200 Library-Electrical Utilities					
Beginning Balance					
					1,013.94
11/15/2019	Bill	111-ALABAMA POWER	00-2010 Accounts Payable	674.74	1,688.68
<b>Total for 70-4200 Library-Electrical Utilities</b>				<b>\$674.74</b>	
70-4203 Library-Cell / Wireless Services					
11/15/2019	Bill	3119-CARD SERVICES (8365)	00-2010 Accounts Payable	52.51	52.51
<b>Total for 70-4203 Library-Cell / Wireless Services</b>				<b>\$52.51</b>	
70-4204 Library-Gas Utilities					
Beginning Balance					
					15.62
11/15/2019	Bill	122-SPIRE INC	LIBRARY	00-2010 Accounts Payable	15.62
11/30/2019	Bill	122-SPIRE INC	LIBRARY	00-2010 Accounts Payable	15.63
<b>Total for 70-4204 Library-Gas Utilities</b>				<b>\$31.25</b>	
70-4206 Library-Water Utilities					
11/15/2019	Bill	3119-CARD SERVICES (8365)	00-2010 Accounts Payable	18.67	18.67
<b>Total for 70-4206 Library-Water Utilities</b>				<b>\$18.67</b>	
70-4208 Library-Sewer Utilities					
11/15/2019	Bill	3119-CARD SERVICES (8365)	00-2010 Accounts Payable	60.50	60.50
<b>Total for 70-4208 Library-Sewer Utilities</b>				<b>\$60.50</b>	
70-4300 Library-Office Supplies					
11/15/2019	Bill	3119-CARD SERVICES (8365)	00-2010 Accounts Payable	157.85	157.85

DATE	TRANSACTION NAME	MEMO/DESCRIPTION	SPLIT	AMOUNT	BALANCE
99					
<b>Total for 70-4300 Library-Office Supplies</b>				<b>\$157.85</b>	
70-4306 Library-Department Supplies					
Beginning Balance					
11/15/2019	Bill	3119-CARD SERVICES (8365)	00-2010 Accounts Payable	61.14	543.72
11/30/2019	Bill	821-QUILL LLC	00-2010 Accounts Payable	21.59	565.31
11/30/2019	Bill	821-QUILL LLC	00-2010 Accounts Payable	183.63	748.94
<b>Total for 70-4306 Library-Department Supplies</b>				<b>\$266.36</b>	
70-4314 Library-Subscriptions					
11/30/2019	Bill	1241-EBSCO	00-2010 Accounts Payable	1,503.71	1,503.71
<b>Total for 70-4314 Library-Subscriptions</b>				<b>\$1,503.71</b>	
70-4316 Library-Dues & Fees					
Beginning Balance					
<b>Total for 70-4316 Library-Dues &amp; Fees</b>					374.00
70-4326 Library-Computer Hardware					
11/15/2019	Bill	3119-CARD SERVICES (8365)	00-2010 Accounts Payable	314.96	314.96
<b>Total for 70-4326 Library-Computer Hardware</b>				<b>\$314.96</b>	
70-4330 Library-Education & Training					
Beginning Balance					
<b>Total for 70-4330 Library-Education &amp; Training</b>					49.00
70-4332 Library-Travel					
11/30/2019	Bill	2829-VIRGINIA EDWARDS	00-2010 Accounts Payable	431.48	431.48
<b>Total for 70-4332 Library-Travel</b>				<b>\$431.48</b>	
70-4350 Library-Books - Juvenile					
Beginning Balance					
11/15/2019	Bill	1749-AMAZON	TRANSACTION 40997998	48.08	297.27
11/15/2019	Bill	476-INGRAM LIBRARY SERVICES	OE# N21T5SHL	25.61	322.88
11/15/2019	Bill	1749-AMAZON	TRANSACTION 40844850	45.06	367.94
11/15/2019	Bill	476-INGRAM LIBRARY SERVICES	OE# N29BT6HL	18.95	386.89
11/15/2019	Bill	476-INGRAM LIBRARY SERVICES	O# N3LF40HL	10.93	397.82
11/15/2019	Bill	1749-AMAZON	TRANSACTION 40728852	16.61	414.43
<b>Total for 70-4350 Library-Books - Juvenile</b>				<b>\$165.24</b>	
70-4352 Library-Books - Adult					
Beginning Balance					
<b>Total for 70-4352 Library-Books - Adult</b>					302.81
11/15/2019	Bill	476-INGRAM LIBRARY SERVICES	OE# N22VHXHL	22.13	324.94
11/15/2019	Bill	476-INGRAM LIBRARY SERVICES	OE# N3LF40HL	68.23	393.17
11/15/2019	Bill	476-INGRAM LIBRARY SERVICES	OE# N3LF40HL	18.02	411.19
11/15/2019	Bill	476-INGRAM LIBRARY SERVICES	OE# N21T5SHL	19.61	430.80
11/15/2019	Bill	476-INGRAM LIBRARY SERVICES	OE# N29BT6HL	20.43	451.23
11/15/2019	Bill	176-CENTER POINT LARGE PRINT	INVOICE 1728321	88.68	539.91
11/15/2019	Bill	1749-AMAZON	TRANSACTION 38693970	17.96	557.87
11/15/2019	Bill	1749-AMAZON	TRANSACTION 38693997	177.93	735.80
11/15/2019	Bill	476-INGRAM LIBRARY SERVICES	OE# N3LF40HL	16.90	752.70
11/15/2019	Bill	1749-AMAZON	TRANSACTION 38720005	14.96	767.66
11/15/2019	Bill	1749-AMAZON	TRANSACTION 38720013	33.30	800.96
11/15/2019	Bill	1749-AMAZON	TRANSACTION 40855401	12.47	813.43
11/15/2019	Bill	1749-AMAZON	TRANSACTION 40997996	42.66	856.09
11/15/2019	Bill	1749-AMAZON	TRANSACTION 38614363	20.53	876.62
11/15/2019	Bill	1749-AMAZON	TRANSACTION 40717317	12.77	889.39
11/15/2019	Bill	476-INGRAM LIBRARY SERVICES	OE# N3BPSSHHL	22.71	912.10
11/15/2019	Bill	476-INGRAM LIBRARY SERVICES	OE# N3PJ0THL	22.70	934.80
11/15/2019	Bill	1749-AMAZON	TRANSACTION 38720019	59.31	994.11
11/30/2019	Bill	176-CENTER POINT LARGE PRINT		88.68	1,082.79
11/30/2019	Bill	476-INGRAM LIBRARY SERVICES		35.42	1,118.21
11/30/2019	Bill	476-INGRAM LIBRARY SERVICES		17.05	1,135.26
11/30/2019	Bill	476-INGRAM LIBRARY SERVICES		17.94	1,153.20
11/30/2019	Bill	476-INGRAM LIBRARY SERVICES		13.20	1,166.40
11/30/2019	Bill	476-INGRAM LIBRARY SERVICES		22.71	1,189.11
11/30/2019	Bill	476-INGRAM LIBRARY SERVICES		19.70	1,208.81
11/30/2019	Bill	476-INGRAM LIBRARY SERVICES		51.18	1,259.99
11/30/2019	Bill	476-INGRAM LIBRARY SERVICES		15.48	1,275.47
11/30/2019	Bill	476-INGRAM LIBRARY SERVICES		20.53	1,296.00
<b>Total for 70-4352 Library-Books - Adult</b>				<b>\$993.19</b>	
70-4354 Library-Audio/Video					
Beginning Balance					
<b>Total for 70-4354 Library-Audio/Video</b>					1,019.06
11/15/2019	Bill	693-MICROMARKETING LLC	ORDER 465166	49.58	1,068.64
11/15/2019	Bill	693-MICROMARKETING LLC	ORDER 465166	151.68	1,220.32

DATE	TRANSACTION TYPE	NAME	MEMO/DESCRIPTION	SPLIT	AMOUNT	BALANCE
11/15/2019	Bill	3119-CARD SERVICES (8365)		00-2010 Accounts Payable	21.15	1,241.47
<b>Total for 70-4354 Library-Audio/Video</b>					<b>\$222.41</b>	
70-4356 Library-Jeff Co Library System						
Beginning Balance						
						3,742.11
11/15/2019	Bill	1749-AMAZON	TRANSACTION 38614353	00-2010 Accounts Payable	14.70	3,756.81
11/15/2019	Bill	1749-AMAZON	TRANSACTION 38614352	00-2010 Accounts Payable	13.56	3,770.37
11/15/2019	Bill	1704a-DELL FINANCIAL SERVICES	CONTRACT# 001-8881491-016	00-2010 Accounts Payable	53.49	3,823.86
11/15/2019	Bill	1704a-DELL FINANCIAL SERVICES	CONTRACT# 001-8881491-015	00-2010 Accounts Payable	177.58	4,001.44
11/15/2019	Bill	519-JEFFERSON COUNTY LIBRARY CO-OP	JCLC MEMBER SERVICES FEES-1ST QTR (OCT-DEC 2019)	00-2010 Accounts Payable	3,434.91	7,436.35
11/15/2019	Bill	519-JEFFERSON COUNTY LIBRARY CO-OP	PC SOFTWARE INSTALLED ON LIBRARY'S COMPUTERS-1ST QTR (OCT-DEC 2019)	00-2010 Accounts Payable	177.41	7,613.76
11/15/2019	Bill	519-JEFFERSON COUNTY LIBRARY CO-OP	LEEDS FY2019-2020 COMPRISE-1ST QTR (OCT-DEC 2019)	00-2010 Accounts Payable	217.37	7,831.13
11/15/2019	Bill	3119-CARD SERVICES (8365)		00-2010 Accounts Payable	348.11	8,179.24
11/15/2019	Bill	2997-UNITI FIBER /dba/ CONTACT NETWORK/INLINE	LIBRARY	00-2010 Accounts Payable	1,054.70	9,233.94
11/15/2019	Bill	1749-AMAZON	TRANSACTION 38657517	00-2010 Accounts Payable	179.08	9,413.02
11/15/2019	Bill	519-JEFFERSON COUNTY LIBRARY CO-OP	RECEIPT PRINTER PAPER	00-2010 Accounts Payable	32.00	9,445.02
11/30/2019	Bill	1704a-DELL FINANCIAL SERVICES		00-2010 Accounts Payable	234.92	9,679.94
11/30/2019	Bill	1704a-DELL FINANCIAL SERVICES		00-2010 Accounts Payable	189.38	9,869.32
<b>Total for 70-4356 Library-Jeff Co Library System</b>					<b>\$6,127.21</b>	
70-4400 Library-Contract Services						
Beginning Balance						
						720.71
11/15/2019	Bill	3119-CARD SERVICES (8365)		00-2010 Accounts Payable	21.28	741.99
<b>Total for 70-4400 Library-Contract Services</b>					<b>\$21.28</b>	
70-4412 Library-Community Programs						
Beginning Balance						
						140.17
11/15/2019	Bill	3119-CARD SERVICES (8365)		00-2010 Accounts Payable	1,366.32	1,506.49
<b>Total for 70-4412 Library-Community Programs</b>					<b>\$1,366.32</b>	
70-4508 Library-Repair & MTC						
Beginning Balance						
						269.70
11/30/2019	Bill	2219-CAUBLE ELECTRICAL CONTRACTOR INC		00-2010 Accounts Payable	145.25	414.95
<b>Total for 70-4508 Library-Repair &amp; MTC</b>					<b>\$145.25</b>	
70-4600 Library-Rent - Building						
Beginning Balance						
						1,000.00
11/30/2019	Bill	631-FRANK W LITTLE - LIBRARY RENT	NOV 2019 RENT	00-2010 Accounts Payable	1,000.00	2,000.00
<b>Total for 70-4600 Library-Rent - Building</b>					<b>\$1,000.00</b>	
70-4601 LIBRARY EXPENSES						
11/30/2019	Bill	476-INGRAM LIBRARY SERVICES		00-2010 Accounts Payable	23.29	23.29
11/30/2019	Bill	476-INGRAM LIBRARY SERVICES		00-2010 Accounts Payable	620.79	644.08
<b>Total for 70-4601 LIBRARY EXPENSES</b>					<b>\$644.08</b>	
<b>Total for 70-4000 Library</b>					<b>\$38,458.88</b>	
80-4000 Streets						
11/15/2019	Bill	122-SPIRE INC	PUBLIC WORKS	00-2010 Accounts Payable	63.64	63.64
<b>Total for 80-4000 Streets</b>					<b>\$63.64</b>	
80-4001 Streets-Salaries & Wages						
Beginning Balance						
						32,709.94
11/08/2019	Expense	PBS		00-1122 General Fund Checking Accounts:Payroll Acct-Servis 1st-1427	16,344.38	49,054.32
11/22/2019	Expense	PBS		00-1122 General Fund Checking Accounts:Payroll Acct-Servis 1st-1427	16,111.08	65,165.40
<b>Total for 80-4001 Streets-Salaries &amp; Wages</b>					<b>\$32,455.46</b>	
80-4002 Streets-Payroll Taxes						
Beginning Balance						
						2,470.24
11/08/2019	Expense	PBS		00-1122 General Fund Checking Accounts:Payroll Acct-Servis 1st-1427	1,234.34	3,704.58
11/22/2019	Expense	PBS		00-1122 General Fund Checking Accounts:Payroll Acct-Servis 1st-1427	1,216.23	4,920.81
<b>Total for 80-4002 Streets-Payroll Taxes</b>					<b>\$2,450.57</b>	
80-4004 Streets-Health Insurance						

DATE	TRANSACTION TYPE	NAME	MEMO/DESCRIPTION	SPLIT	AMOUNT	BALANCE
101						
		Beginning Balance				5,983.50
11/08/2019	Expense	PBS		00-1122 General Fund Checking Accounts:Payroll Acct-Servis 1st-1427	-221.75	5,761.75
11/15/2019	Bill	2601-LOCAL GOVERNMENT HEALTH INSURANCE BOARD	PUBLIC WORKS	00-2010 Accounts Payable	6,888.00	12,649.75
11/22/2019	Expense	PBS		00-1122 General Fund Checking Accounts:Payroll Acct-Servis 1st-1427	-221.75	12,428.00
<b>Total for 80-4004 Streets-Health Insurance</b>					<b>\$6,444.50</b>	
80-4006 Streets-Retirement						
		Beginning Balance				2,273.10
11/08/2019	Expense	851- Retirement Systems of Alabama		00-1114 General Fund Checking Accounts:Gen'l Fund-Servis 1st-4304	915.44	3,188.54
11/25/2019	Expense	851- Retirement Systems of Alabama		00-1114 General Fund Checking Accounts:Gen'l Fund-Servis 1st-4304	894.20	4,082.74
<b>Total for 80-4006 Streets-Retirement</b>					<b>\$1,809.64</b>	
80-4012 Streets-Uniforms						
11/15/2019	Bill	3119-CARD SERVICES (8365)		00-2010 Accounts Payable	590.80	590.80
<b>Total for 80-4012 Streets-Uniforms</b>					<b>\$590.80</b>	
80-4015 Streets-Ee Life & Disability Ins						
		Beginning Balance				214.16
11/15/2019	Bill	2725a-MUTUAL OF OMAHA		00-2010 Accounts Payable	81.75	295.91
11/30/2019	Bill	2725a-MUTUAL OF OMAHA		00-2010 Accounts Payable	81.75	377.66
11/30/2019	Bill	2725a-MUTUAL OF OMAHA		00-2010 Accounts Payable	16.64	394.30
11/30/2019	Bill	2725b-MUTUAL OF OMAHA		00-2010 Accounts Payable	81.75	476.05
<b>Total for 80-4015 Streets-Ee Life &amp; Disability Ins</b>					<b>\$261.89</b>	
80-4018 Streets-Employment Expense						
11/15/2019	Bill	3119-CARD SERVICES (8365)		00-2010 Accounts Payable	230.00	230.00
<b>Total for 80-4018 Streets-Employment Expense</b>					<b>\$230.00</b>	
80-4200 Streets-Electrical Utilities						
		Beginning Balance				720.49
11/15/2019	Bill	111-ALABAMA POWER		00-2010 Accounts Payable	338.01	1,058.50
<b>Total for 80-4200 Streets-Electrical Utilities</b>					<b>\$338.01</b>	
80-4202 Streets-Telephone						
11/15/2019	Bill	3119-CARD SERVICES (8365)		00-2010 Accounts Payable	183.48	183.48
<b>Total for 80-4202 Streets-Telephone</b>					<b>\$183.48</b>	
80-4203 Streets-Cell / Wireless Services						
11/15/2019	Bill	3119-CARD SERVICES (8365)		00-2010 Accounts Payable	105.86	105.86
<b>Total for 80-4203 Streets-Cell / Wireless Services</b>					<b>\$105.86</b>	
80-4204 Streets-Gas Utilities						
		Beginning Balance				62.25
11/30/2019	Bill	122-SPIRE INC	SHOP & RECYCLING	00-2010 Accounts Payable	65.73	127.98
<b>Total for 80-4204 Streets-Gas Utilities</b>					<b>\$65.73</b>	
80-4206 Streets-Water Utilities						
11/15/2019	Bill	3119-CARD SERVICES (8365)		00-2010 Accounts Payable	228.92	228.92
<b>Total for 80-4206 Streets-Water Utilities</b>					<b>\$228.92</b>	
80-4208 Streets-Sewer Utilities						
11/15/2019	Bill	3119-CARD SERVICES (8365)		00-2010 Accounts Payable	106.73	106.73
<b>Total for 80-4208 Streets-Sewer Utilities</b>					<b>\$106.73</b>	
80-4304 Streets-Copier & Printer Mtc						
11/15/2019	Bill	3119-CARD SERVICES (8365)		00-2010 Accounts Payable	2.85	2.85
<b>Total for 80-4304 Streets-Copier &amp; Printer Mtc</b>					<b>\$2.85</b>	
80-4306 Streets-Department Supplies						
11/15/2019	Bill	3119-CARD SERVICES (8365)		00-2010 Accounts Payable	4,341.18	4,341.18
<b>Total for 80-4306 Streets-Department Supplies</b>					<b>\$4,341.18</b>	
80-4400 Streets-Contract Services						
		Beginning Balance				834.71
11/15/2019	Bill	3119-CARD SERVICES (8365)		00-2010 Accounts Payable	2,420.10	3,254.81
<b>Total for 80-4400 Streets-Contract Services</b>					<b>\$2,420.10</b>	
80-4500 Streets-Repair & Maint Auto						
11/15/2019	Bill	3119-CARD SERVICES (8365)		00-2010 Accounts Payable	338.68	338.68
<b>Total for 80-4500 Streets-Repair &amp; Maint Auto</b>					<b>\$338.68</b>	
80-4508 Streets-Repair & MTC - Building						

DATE	TRANSACTION TYPE	NAME	MEMO/DESCRIPTION	SPLIT	AMOUNT	BALANCE
102						
11/15/2019	Bill	3119-CARD SERVICES (8365)		00-2010 Accounts Payable	9.98	9.98
11/30/2019	Bill	2219-CAUBLE ELECTRICAL CONTRACTOR INC		00-2010 Accounts Payable	334.39	344.37
<b>Total for 80-4508 Streets-Repair &amp; MTC - Building</b>					<b>\$344.37</b>	
80-4510 Streets-Repair & MTC - Streets						
11/15/2019	Bill	985-STONE & SONS ELECTRICAL CONTRACTORS INC		00-2010 Accounts Payable	236.78	236.78
11/15/2019	Bill	985-STONE & SONS ELECTRICAL CONTRACTORS INC		00-2010 Accounts Payable	114.28	351.06
11/15/2019	Bill	3119-CARD SERVICES (8365)		00-2010 Accounts Payable	2,056.60	2,407.66
<b>Total for 80-4510 Streets-Repair &amp; MTC - Streets</b>					<b>\$2,407.66</b>	
80-4516 Streets-Repair & MTC - Grounds						
11/15/2019	Bill	3119-CARD SERVICES (8365)		00-2010 Accounts Payable	19.99	19.99
<b>Total for 80-4516 Streets-Repair &amp; MTC - Grounds</b>					<b>\$19.99</b>	
80-4520 Streets-Fuel Expense - Auto						
Beginning Balance						1,441.80
11/15/2019	Bill	3119-CARD SERVICES (8365)		00-2010 Accounts Payable	315.49	1,757.29
11/30/2019	Bill	1770-WEX BANK	PUBLIC WORKS	00-2010 Accounts Payable	1,340.68	3,097.97
<b>Total for 80-4520 Streets-Fuel Expense - Auto</b>					<b>\$1,656.17</b>	
80-4530 Streets-Department Tools						
11/15/2019	Bill	3119-CARD SERVICES (8365)		00-2010 Accounts Payable	919.30	919.30
<b>Total for 80-4530 Streets-Department Tools</b>					<b>\$919.30</b>	
80-4604 Streets-Equipment Rent/Lease						
11/15/2019	Bill	3119-CARD SERVICES (8365)		00-2010 Accounts Payable	148.45	148.45
<b>Total for 80-4604 Streets-Equipment Rent/Lease</b>					<b>\$148.45</b>	
80-6704 Streets-Asset Purchase						
11/22/2019	Bill	ALTEC NUECO	2015 FORD F550 AT40G; VIN# 1FDUF5HT1FED32905	00-2010 Accounts Payable	74,000.00	74,000.00
<b>Total for 80-6704 Streets-Asset Purchase</b>					<b>\$74,000.00</b>	
<b>Total for 80-4000 Streets with subs</b>					<b>\$131,933.98</b>	
83-4000 Solid Waste Exp						
83-4210 Solid Waste-Disposal Fee						
11/15/2019	Bill	3119-CARD SERVICES (8365)		00-2010 Accounts Payable	7,209.24	7,209.24
<b>Total for 83-4210 Solid Waste-Disposal Fee</b>					<b>\$7,209.24</b>	
83-4300 Solid Waste-Department Supplies						
11/15/2019	Bill	3119-CARD SERVICES (8365)		00-2010 Accounts Payable	180.00	180.00
<b>Total for 83-4300 Solid Waste-Department Supplies</b>					<b>\$180.00</b>	
83-4502 Solid Waste-Repair & MTC -Auto						
Beginning Balance						39.96
11/15/2019	Bill	3119-CARD SERVICES (8365)		00-2010 Accounts Payable	1,544.00	1,583.96
<b>Total for 83-4502 Solid Waste-Repair &amp; MTC -Auto</b>					<b>\$1,544.00</b>	
83-4520 Solid Waste-Fuel Expense-Solid Waste						
Beginning Balance						1,429.35
11/30/2019	Bill	1770-WEX BANK	SOLID WASTE FUEL	00-2010 Accounts Payable	1,442.08	2,871.43
<b>Total for 83-4520 Solid Waste-Fuel Expense-Solid Waste</b>					<b>\$1,442.08</b>	
<b>Total for 83-4000 Solid Waste Exp</b>					<b>\$10,375.32</b>	

City of Leeds-Debt Service

EXPENSE DETAIL

November 2019

DATE	TRANSACTION TYPE	NUM	ADJ	NAME	MEMO/DESCRIPTION	SPLIT	AMOUNT	BALANCE
<b>09-4716 PLEDGED REVENUES</b>								
	Beginning Balance							225,864.38
11/15/2019	Bill	DS-1001005673	No	3151-REGIONS CORPORATE TRUST	LEEDS TAXABLE GENERAL OBLIGATION SERIES 2018 WARRANTS	Accounts Payable (A/P)	225,864.38	451,728.76
<b>Total for 09-4716 PLEDGED REVENUES</b>							<b>\$225,864.38</b>	
<b>09-6100 BOND FEES</b>								
	Beginning Balance							2,295.63
11/30/2019	Bill	DEBT-INV 75190	No	2331- REGIONS CORP TRUST OPERATIONS	LEEDS PEBA EDUCATIONAL FACILITIES REVENUE SERIES 2015 Bl# 7362	Accounts Payable (A/P)	3,406.25	5,701.88
<b>Total for 09-6100 BOND FEES</b>							<b>\$3,406.25</b>	
<b>09-6200 GEN OBLIG PRINCIPAL RET</b>								
	Beginning Balance							21,250.00
11/15/2019	Bill	DS-1041014383	No	3152-REGIONS CORPORATE TRUST	LESS EXCESS FUNDS	Accounts Payable (A/P)	-1,454.70	19,795.30
11/15/2019	Bill	DS-1041014383	No	3152-REGIONS CORPORATE TRUST	LEEDS GENERAL OBLIGATION SERIES 2017A WARRANTS	Accounts Payable (A/P)	21,666.67	41,461.97
<b>Total for 09-6200 GEN OBLIG PRINCIPAL RET</b>							<b>\$20,211.97</b>	
<b>09-6202 GEN OBLIG INTEREST</b>								
	Beginning Balance							12,592.71
11/15/2019	Bill	DS-1041014383	No	3152-REGIONS CORPORATE TRUST	LESS EXCESS FUNDS	Accounts Payable (A/P)	-1,454.70	11,138.01
11/15/2019	Bill	DS-1041014383	No	3152-REGIONS CORPORATE TRUST	LEEDS GENERAL OBLIGATION SERIES 2017A WARRANTS	Accounts Payable (A/P)	12,167.71	23,305.72
<b>Total for 09-6202 GEN OBLIG INTEREST</b>							<b>\$10,713.01</b>	
<b>09-6999 Account Transfer</b>								
	Beginning Balance							-47,093.29
11/20/2019	Sales Receipt	3761	No	18558 - CITY OF LEEDS - DEBT REDUCTION	NOV 2019 TRANSFER	Undeposited Funds	-11,290.74	-58,384.03
<b>Total for 09-6999 Account Transfer</b>							<b>\$ - 11,290.74</b>	
<b>19-6507 19-6507 Primary School Constr.- Long Term Debt</b>								
	Beginning Balance							33,333.33
11/15/2019	Bill	DS-1001001075	No	68- REGIONS CORPORATE TRUST	Primary School Constr.- Long Term Debt	Accounts Payable (A/P)	33,333.33	66,666.66
<b>Total for 19-6507 19-6507 Primary School Constr.- Long Term Debt</b>							<b>\$33,333.33</b>	
<b>19-6508 19-6508 Primary School Constr.-Long Term Interest</b>								
	Beginning Balance							35,473.44
11/15/2019	Bill	DS-1001001075	No	68- REGIONS CORPORATE TRUST	Primary School Constr.-Long Term Interest	Accounts Payable (A/P)	35,473.44	70,946.88
<b>Total for 19-6508 19-6508 Primary School Constr.-Long Term Interest</b>							<b>\$35,473.44</b>	
<b>26-6300 26-6300 Fire-Long Term Debt-Fire Truck</b>								
	Beginning Balance							47,093.29
<b>Total for 26-6300 26-6300 Fire-Long Term Debt-Fire Truck</b>								
<b>40-6300 40-6300 Parks Long Term Debt Prin Retirement</b>								
	Beginning Balance							17,133.02
11/15/2019	Bill	DS-1041014392	No	3153-REGIONS CORPORATE TRUST	LEEDS GENERAL OBLIGATION SERIES 2017B WARRANTS	Accounts Payable (A/P)	15,438.14	32,571.16
<b>Total for 40-6300 40-6300 Parks Long Term Debt Prin Retirement</b>							<b>\$15,438.14</b>	

# City of Leeds-Gas Taxes

## EXPENSE DETAIL

November 2019

DATE	TRANSACTION TYPE	NUM	ADJ	NAME	MEMO/DESCRIPTION	SPLIT	AMOUNT	BALANCE
07-4000 Seven Cent Expenses								
07-4200 ELECTRICAL UTILITIES								
Beginning Balance								
11/15/2019	Bill	7C-OCT 2019	No	111-ALABAMA POWER		Accounts Payable (A/P)	13,503.64	26,831.98
<b>Total for 07-4200 ELECTRICAL UTILITIES</b>							<b>\$13,503.64</b>	
07-4510 7 CT RPR & MTC - STREETS								
Beginning Balance								
<b>Total for 07-4510 7 CT RPR &amp; MTC - STREETS</b>								49,988.42
<b>Total for 07-4000 Seven Cent Expenses</b>							<b>\$13,503.64</b>	



**Item Attachment Documents:**

18. Resolution 2019-12-03 (Carried over from the canceled meeting - December 16, 2019)  
Consider Authorizing and Approving Library Collection Development Grant (Budgeted Item)

**CITY OF LEEDS**

**RESOLUTION NO.: 2019-12-03**

**AUTHORIZING AND APPROVING LIBRARY COLLECTION DEVELOPMENT GRANT**

**WHEREAS**, the Leeds Jane Culbreth Library received the attached notice and grant agreement providing for an award of up to \$20,000.00 regarding project #20-4-14 subject to a local match amount of \$5000.00; and

**WHEREAS**, the funds to be received are part of the Collection Development program of the Alabama Public Library Service and are to be used generally for Library Materials; and

**WHEREAS**, receipt of the subject Grant is due to be approved by the City Council.

**NOW, THEREFORE BE IT RESOLVED BY THE CITY COUNCIL OF THE CITY OF LEEDS, ALABAMA, AS FOLLOWS:**

1. The above Recitals are true and correct and included herein as if fully set forth.
2. The City Council hereby finds it to be in the best interest of the City to authorize and approve the attached Grant for the benefit of the Leeds Jane Culbreth Library which shall include the allocation and approval for a monetary match to be expended in the amount for \$5000.00.
3. The Mayor, City staff, and City Attorneys shall have the full authority to do those things, perform those functions, and to sign necessary documentation in order to carry out the actions so authorized herein.

**APPROVED AND ADOPTED** at a regular meeting of the City Council of the City of Leeds, Alabama on this the 6<sup>th</sup> day of January 2020

**AYES:** \_\_\_\_\_  
**NAYS:** \_\_\_\_\_  
**ABSENT FROM VOTING:** \_\_\_\_\_  
**ABSTAIN:** \_\_\_\_\_

**CITY OF LEEDS, ALABAMA**

\_\_\_\_\_  
David Miller, Mayor

\_\_\_\_\_  
DATE

**ATTEST:**

\_\_\_\_\_  
Toushi Arbitelle, City Clerk

In my capacity as the City Clerk of the City of Leeds, hereby certify that the above Resolution was duly adopted by the City Council of the City of Leeds at a regular meeting held on the 6th day of January 2020

\_\_\_\_\_  
City Clerk

AGREEMENT BETWEEN THE ALABAMA PUBLIC LIBRARY SERVICE AND LIBRARY BOARDS OF PUBLIC LIBRARY REGIONS OF ALABAMA

The Alabama Public Library Service agrees to provide, from the funds available under the Library Services and Technology Act, a grant to Leeds Jane Culbreth Library not to exceed \$15,000 for COLLECTION DEVELOPMENT, Project #20-4-14.

PROVIDED:

1. The Library is in good standing and is in full compliance with the *Alabama Administrative Code* regarding the criteria necessary to receive State Aid.
2. These funds will be expended to provide library service in accordance with the project application approved by the Alabama Public Library Service which is considered a part of this contract.
3. That financial, narrative, interim, and annual reports be submitted in accordance with directions under separate cover. Records shall be kept in such a way that it will be possible for Alabama Public Library Service to determine whether the proposed program of library service is successfully carried out.
4. If the grant conditions are not complied with, the Alabama Public Library Service reserves the right to cancel this contract or revise the plan of service.
5. The financial records of the library will be made available, on request, to the federal government, Alabama Department of Examiners of Public Accounts, and/or the Alabama Public Library Service. Based upon review of these financial records, an audit of the Library System's records by a licensed certified public accountant may be required to determine the true financial status of the library.
6. The Library Board agrees to maintain a grant project record in the form prescribed by the Alabama Public Library Service and retain all records until **at least** December 31, 2026.
7. The Library Board agrees to properly manage all equipment (including replacement equipment) purchased with these funds and will meet the recordkeeping and management standards established by the Alabama Public Library Service.
8. The Library Board agrees to abide by and follow (a) all applicable rules and regulations of the U.S. Institute of Museum and Library Services, (b) the Library Services and Technology Act, and (c) the Financial Management and Administrative Policies and Procedures established by the Alabama Public Library Service pertaining to the use of the funds.
9. This agreement shall be in effect from the date the agreement is signed by the Director of the Alabama Public Library Service through **June 30, 2020**. Funds not requested by **June 15, 2020** will no longer be available unless the Alabama Public Library Service receives and approves a request for a contract extension. Contract extensions will only be granted in very unusual circumstances.
10. The following sections are attached and incorporated into this agreement:
  - a. Certification Regarding Civil Rights; Debarment and Suspension; Standard Assurances
  - b. Internet Safety Certification

RECEIVED  
OCT 28 2019  
ADMIN

11. The Library Board agrees that the appropriate percentage of required matching funds shall be in cash and verifies that the required matching cash is available as of the date this agreement is signed by the Board Chair.

Leeds Jane Culbreth Library  
LIBRARY

Michael J Woodell  
BOARD CHAIR

**NOTARY CERTIFICATE**

Sworn to and subscribed before me this 24<sup>th</sup> day of October, 2019.

Gregory W. Glaze  
Notary Public

MY COMMISSION EXPIRES SEPTEMBER 6, 2021

APPROVED:

Nancy C. Packer  
Director, Alabama Public Library Service

10/30/19  
Date



RECEIVED  
OCT 28 2019  
ADMIN

# CERTIFICATION REGARDING CIVIL RIGHTS; DEBARMENT AND SUSPENSION; STANDARD ASSURANCES

## CIVIL RIGHTS

The grantee assures that it will comply with:

- i. Title VI of the Civil Rights Act of 1964, as amended, 42 USC 2000d et seq., which prohibits discrimination on the basis of race, color, or national origin in programs and activities receiving Federal financial assistance.
- ii. Section 504 of the Rehabilitation Act of 1973, as amended, 29 USC 794, which prohibits discrimination on the basis of handicap in programs and activities receiving Federal assistance.
- iii. Title IX of the Education Amendments of 1972, as amended, 20 USC 1681 et seq., which prohibits discrimination on the basis of sex in education programs and activities receiving Federal financial assistance.
- iv. The Age Discrimination Act of 1975, as amended, 42 USC 6101 et seq., which prohibits discrimination on the basis of age in programs or activities receiving Federal financial assistance.
- v. All regulations, guidelines, and standards lawfully adopted under the above statutes by the Institute of Museum and Library Services (IMLS).

## DEBARMENT AND SUSPENSION

The grantee assures that it will comply with 2 CFR Part 3185 and certifies to the best of its knowledge that **neither** the grantee **nor** any of its principals:

- i. Are presently excluded or disqualified;
- ii. Have been convicted within the preceding three years of any of the offenses listed in 2 CFR section 180.800(a) or had a civil judgment rendered against you for one of those offenses within that time period;
- iii. Are presently indicted for or otherwise criminally or civilly charged by a governmental entity (Federal, State or local) with commission of any of the offenses listed in 2 CFR section 180.800(a); or
- iv. Have had one or more public transactions (Federal, State, or local) terminated within the preceding three years for cause or default.

RECEIVED  
OCT 28 2019  
ADMIN

# CERTIFICATION REGARDING CIVIL RIGHTS; DEBARMENT AND SUSPENSION; STANDARD ASSURANCES

<b>STANDARD ASSURANCES</b>	
The grantee hereby assures and certifies that:	
i.	It will comply with the regulations, policies, guidelines, and requirements imposed by the Institute of Museum and Library Services (IMLS) and the Alabama Public Library Service (APLS).
ii.	It has legal authority to apply for, receive, and administer the grant through a resolution, motion, or similar action that has been duly adopted or passed by an official act of their governing body.
iii.	It will establish safeguards to prohibit employees and members of the governing or policy-making bodies from making decisions that would directly or indirectly benefit them financially.
iv.	It will establish and maintain fiscal and program controls that will allow for monitoring, examination or auditing of all records that pertain to this grant by the Alabama Public Library Service (APLS), the Comptroller General of the United States, the Alabama Department of Examiners of Public Accounts or a duly designated representative.
v.	It will maintain such books and records until <b>at least</b> December 31, 2026.

Leeds Jane Culbreth Library  
Library

Melanie A. Carden  
Signature of Authorized Official

10/24/19  
Date

**INTERNET SAFETY CERTIFICATION FOR  
LSTA PROGRAMS  
PROGRAM YEAR 2019 FUNDS (TO BE SPENT IN FY2020)**

1. In the period of your contract with APLS (in most cases starting in October 2019, through June 30, 2020) will the library use LSTA funds to purchase computers used to access the Internet or to pay for direct costs associated with accessing the Internet?  
 Yes     No

2. Does the library already have in place an Internet safety policy that meets the following requirements (as provided by 20 U.S.C. Section 9134(f)(1))?  
a. A policy of Internet safety for minors that includes the operation of a technology protection measure with respect to any of its computers with Internet access that protects against access through such computers to visual depictions that are: (1) obscene; (2) child pornography; or (3) harmful to minors; and the library is enforcing the operation of such technology protection measure during any use of such computers by minors; and  
b. A policy of Internet safety that includes the operation of a technology protection measure with respect to any of its computers with Internet access that protects against access through such computers to visual depictions that are: (1) obscene; (2) child pornography; or (3) harmful to minors; and the library is enforcing the operation of such technology protection measure during any use of such computers.

Yes     No

**Select appropriate box on next page and complete the signature and notary sections.**

**RECEIVED**  
**OCT 28 2019**  
**ADMIN**

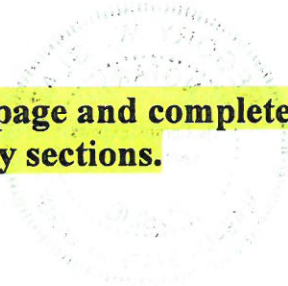

INTERNET SAFETY CERTIFICATION FOR  
LSTA PROGRAMS  
PROGRAM YEAR 2019 FUNDS (TO BE SPENT IN FY2020)

- 1.  As its duly authorized representative, I hereby certify that the applicant library **will** use PY2019 LSTA funds to purchase computers used to access the Internet or to pay for direct costs associated with accessing the Internet and has complied with the requirements of Section 9134(f)(1) of the Library Services and Technology Act.
- 2.  As its duly authorized representative, I hereby certify that the applicant library **will not** use PY2019 LSTA funds to purchase computers used to access the Internet or to pay for direct costs associated with accessing the Internet and that the requirements of Section 9134(f) of the Library Services and Technology Act do not apply to the applicant library.

Melanie A. Carden

Signature of Authorized Representative

Melanie A. Carden

Printed Name of Authorized Representative

Library Director

Title of Authorized Representative

Oct 24, 2019

Date

Leeds Jane Culbreth Library

Name of Applicant Library

STATE OF ALABAMA

COUNTY OF Jefferson

Subscribed and sworn to before me this 24th day of October, in the year 2019.

Gregory W. Glaze

Notary Public

Notary's commission expires: MY COMMISSION EXPIRES SEPTEMBER 6, 2021





**Deadline: April 8, 2019**

113

**ALABAMA PUBLIC LIBRARY SERVICE  
FY2020 LSTA COLLECTION DEVELOPMENT GRANT APPLICATION  
INSTRUCTIONS AND EVALUATION CRITERIA ON PAGES 9 - 14**

Library name (Where a system is administering a member's project, enter both the system and member name) <b>LEEDS JANE CULBRETH LIBRARY</b>		E-mail address of project administrator <b>MCARDEN@BHAM.LIB.AL.US</b>
Library address <b>8104 PARKWAY DRIVE</b>	City / County <b>LEEDS / JEFFERSON, ST. CLAIR &amp; SHELBY</b>	Zip Code <b>35094</b>
Project administrator <b>MELANIE CARDEN, DIRECTOR</b>	Phone number <b>(205) 699 -5962</b>	FAX number <b>(205) 699 -6843</b>

**A. GRANT PROGRAM:** (Select one of the programs below.)

**GENERAL:**

	<b>PROGRAM</b>	<b>LSTA AWARD CAP</b>	<b>LOCAL MATCH</b>
<input checked="" type="checkbox"/>	Collection Development	\$20,000	\$5,000 (25% of LSTA)**

**SMALL LIBRARY DEVELOPMENT (Population 10,000 or less):**

	<b>PROGRAM</b>	<b>LSTA AWARD CAP</b>	<b>LOCAL MATCH</b>
<input type="checkbox"/>	Collection Development (SLD)	\$10,000	\$2,500 (25% of LSTA)**

**B. BUDGET SUMMARY:** Complete the Budget Summary table using the amounts from the budget detail tables in Section G. (Budget Information). **\*\*Project personnel salaries may comprise up to 25% of match. Round all figures to the nearest dollar.**

BUDGET CATEGORY	LSTA FUNDS	LOCAL MATCH	TOTAL FUNDS
Salaries		\$	\$
Travel	\$	\$	\$
Equipment	\$	\$	\$
Supplies	\$750.00	\$250.00	\$1,000.00
Contractual	\$	\$	\$
Library Materials	\$14,250.00	\$4,750.00	\$19,000.00
<b>GRAND TOTALS</b>	<b>\$15,000.00</b>	<b>\$5,000.00</b>	<b>\$20,000.00</b>

**C. POPULATION INFORMATION:** Enter the name of the county or counties served, the age(s) of the targeted group(s), and the estimated number of persons to be served by this project.

- Name of county or counties served: JEFFERSON, ST. CLAIR, & SHELBY.
- Age(s) of the targeted group(s):  All ages  0-5  6-12  13-17  18-25  
 26-49  50-59  60-69  70+
- Estimated total number of persons to be served by this project: 5,000

114

[This is not necessarily your entire service population. Use your patron statistics as a guide if you are targeting a specific group.]

**D. DISTRICT INFORMATION:** Enter the number(s) for each specified district.  
 [Go to [Find My Legislator](#) and enter your address or 9-digit zip code and click “Go”.]

1. Congressional District(s): 6th
2. State House District(s): 45th
3. State Senate District(s): 15th

**E. PROJECT SUMMARY:** Give a brief description of the project including project purpose and objectives. Limit response to 150 words or less.

Leeds Jane Culbreth Library would like to update the adult nonfiction printed collection so it may better serve library users aged 13 and above. Currently, 74% of the adult nonfiction collection consists of printed materials that are over ten years old and have not circulated within two years. Our goal is to purchase updated biographies and nonfiction printed materials that would anticipate the needs of middle school students, high school students, and curious adults. These new items could offer multiple opportunities for library users to pursue lifelong learning, keep abreast of new ideas, improve occupational performance, and become better informed citizens. We plan to highlight the new collection through book displays, online promotions, and hosting a variety of educational programs throughout the 2020 calendar year.

**F. PROJECT NARRATIVE: [IMPORTANT:** The narrative should be clear, succinct, persuasive and written for evaluators who may not be familiar with your library or with the technical aspects of your project.]

**1. Library Users and Need:**

a. Who are the current or future library users this project will benefit? (Select all that apply.)

<input checked="" type="checkbox"/> Adults	<input checked="" type="checkbox"/> People living below poverty level
<input type="checkbox"/> Children	<input type="checkbox"/> Rural
<input type="checkbox"/> Disabled	<input checked="" type="checkbox"/> Seniors
<input type="checkbox"/> English as a Second Language (ESL)	<input checked="" type="checkbox"/> Teens
<input type="checkbox"/> Families	<input checked="" type="checkbox"/> Unemployed
<input type="checkbox"/> Institutionalized	<input type="checkbox"/> Other (Please describe: )

b. Describe how the need for this project was determined and the extent of the current problem(s) for the users. [Include demographic information about the targeted group(s) and how the project will be of benefit to them (i.e. What is the percentage of each of the selected users in your community? What is the unemployment rate in the area? What is the percentage of students who participate in and/or are eligible for reduced lunches? What is the percentage of persons who have completed high school? What is the state of the local economy? Have businesses closed resulting in a loss of revenue?)]

[QuickFacts Alabama](#)

[FactFinder Alabama](#)

[CensusViewer](#)

[Kids Count Data Center Alabama](#)

[AL Free/Reduced Lunch](#)

115

The importance of Leeds Jane Culbreth Library can be seen through the amount of foot-traffic, memberships, and circulation every month. An average of 3,000 people visits the library each month. Approximately 43% of the 12,000 citizens of Leeds, Alabama, have an active library card account and these cardholders check out over 5,000 physical items on a monthly basis. To continue being a necessary resource for our community, Leeds Jane Culbreth Library understands the need to improve the printed collection of biographies and nonfiction materials for our general library users. For example, library staff members are unable to simply walk to our shelves to locate printed materials on topics such as climate change, LGBTQ history, "fake news" identification, cyber-attack protection, or various biographies. Those unavailable books must be requested from other branches within Jefferson County Library Cooperative or through Interlibrary Loan using WorldCat.org. This procedure can have a lengthy wait time and can be discouraging to those in need of these printed resources.

Our library visitors view Leeds Jane Culbreth Library as a place to find free resources for educational, vocational, and entertainment purposes. According to the United States Census Bureau, 88.3% of persons age 25 years and older obtained a high school diploma or higher; however, less than 28% of those citizens have obtained a Bachelor’s degree or higher. Approximately 37% of the Leeds population, age 16 years and older, are not an employed member of the labor force. Many of our library visitors utilize the public computers for job searching and updating resumes due to the fact that 14.3% of households are without a computer and 25.9% of households are without broadband internet. The per capita income is approximately \$29,236 and the median household income is \$62,773. Also, over 12% of the local citizens are under the poverty level and 48.28% of students enrolled in the Leeds City School system participate in the Free/Reduced lunch program, according to the most recent statistics from Alabama State Department of Education.

Therefore, Leeds Jane Culbreth Library would like to update our adult nonfiction and biography collections as many of the books are outdated and no longer relevant to our 21st century society. Our goal is to continue assisting a community in need, but our municipality's revenue cannot keep up with the demand. The City of Leeds earmarks \$7,000.00 each fiscal year for all printed books for our Adult and Young Adult readers. This budget equates to a combined monthly amount of \$583.00 for Adult and Young Adult printed materials, or \$291.50 per department each month. According to city officials, this lack of funding is in direct relation to the amount of deficit experienced from a lack of city revenue. The City of Leeds is working towards various projects to increase tax revenue, but 40% of the storefronts along the downtown portion of Parkway Drive have been vacant for a number of years. Furthermore, a property tax millage increase, which would have introduced a new stream of revenue to our municipality, was voted down by local citizens in January 2019. Unfortunately, the revenue stream is not available to support such a large-scale community investment for Leeds, Alabama.

**2. Intended Outcomes:**

a. Select up to **three** intended outcomes for your project from the choices below:

<p><b>INTENDED OUTCOMES (CIVIC ENGAGEMENT):</b>  <i>(Improve user engagement through their library that furthers the common or community good; OR Improve users' ability to engage in their community)</i></p> <p><input checked="" type="checkbox"/> Improve users' ability to participate in community conversations around topics of concern</p> <p><input type="checkbox"/> Improve users' ability to participate in their community</p>
<p><b>INTENDED OUTCOMES (EMPLOYMENT &amp; ECONOMIC DEVELOPMENT):</b> <i>(Improve users' ability to apply information that furthers the status of their jobs and/or business)</i></p> <p><input type="checkbox"/> Improve users' ability to use and apply business resources</p>

<input checked="" type="checkbox"/> Improve users' ability to use resources and apply information for employment support
<p><b>INTENDED OUTCOMES (HUMAN SERVICES):</b>  <i>(Improve users' ability to apply information that furthers their personal, family or household circumstances)</i></p> <input type="checkbox"/> Improve users' ability to apply information that furthers their parenting and family skills <input type="checkbox"/> Improve users' ability to apply information that furthers their personal, family, or household finances <input type="checkbox"/> Improve users' ability to apply information that furthers their personal or family health & wellness
<p><b>INTENDED OUTCOMES (INFORMATION ACCESS):</b> <i>(Improve access to information)</i></p> <input type="checkbox"/> Improve users' ability to discover information <input checked="" type="checkbox"/> Improve users' ability to obtain information resources
<p><b>INTENDED OUTCOMES (INSTITUTIONAL CAPACITY):</b> <i>(Add, improve or update a library function or operation in order to further its effectiveness)</i></p> <input type="checkbox"/> Improve library operations <input type="checkbox"/> Improve the library workforce <input type="checkbox"/> Improve the library's physical and technological infrastructure
<p><b>INTENDED OUTCOMES (LIFELONG LEARNING):</b> <i>(Improve users' knowledge or abilities beyond basic access to information)</i></p> <input type="checkbox"/> Improve users' formal education <input type="checkbox"/> Improve users' general knowledge and skills

b. Why were these outcomes selected for this project? (Be specific.)

**IMPROVE USERS' ABILITY TO PARTICIPATE IN COMMUNITY CONVERSATIONS AROUND TOPICS OF CONCERN:** We hope to add printed resources that will cover a variety of topics to expand our library users' scope of the world around them and strengthen their critical thinking skills. Our "Current Events Café" program will be geared towards our adult library users and will occur on a bi-monthly basis. This program series will highlight a variety of domestic and/or international issues covered in daily news reports, such as cybersecurity, immigration and human rights, gun control/responsible gun ownership, and the science of climate change. Our goal is to offer such a program that will provide information from both sides of the issue and allow the participants to have a civil discussion amongst the group.

**IMPROVE USERS' ABILITY TO USE RESOURCES AND APPLY INFORMATION FOR EMPLOYMENT SUPPORT:** A vast number of our regular library users are in search of employment and on what skills he/she will need to be hired in the 21<sup>st</sup> century. We would conduct a 4 - 6 week

workshop entitled "Let's Get to Work" that will walk our participants through updating their basic computer skills, applying for a job online, building a resume, how to prepare for an interview, and host practice interviews that would be critiqued. As we conduct these workshops, we would promote the updated printed materials that support that week's lesson. At the end of each 4 - 6 week workshop, participants would receive a certificate of completion and would gain a professional reference from our Library Director.

**IMPROVE USERS' ABILITY TO OBTAIN INFORMATION RESOURCES:** As we add more relevant printed resources to our circulating Adult nonfiction collection, we will remove the outdated material. Furthermore, the library staff will help draw attention to the new additions through daily interactions with our library users and a variety of book displays. Our "Current Events Café" and "Let's Get to Work" programs will be geared towards our targeted group and showcase topics found within our updated nonfiction collection.

### 3. Goals and Activities:

- a. How does the proposed project support your library's mission and goals of your five-year plan? (Include specific goals and objectives, if possible.)

By updating the adult nonfiction collection and coordinating educational programming to highlight the collection, Leeds Jane Culbreth Library will be supporting the two most important objectives found in Leeds Jane Culbreth Library's Five Year Plan. These two objectives state that the library will "assemble, make available and maintain print and non-print materials in organized collections which will provide information and recreation for citizens of all ages in the community" and "support educational, civic, and cultural activities of community groups and organizations." Furthermore, the mission of the Leeds Jane Culbreth Library is to provide the community with materials and programs to meet its ever-changing needs for lifelong learning, cultural enrichment, information, and entertainment. At the project's conclusion, we hope to house materials that will inform the general public about topics and issues within today's society, such as "fake news" identification or cyberattack protection, which are imperative needs of our community.

- b. How does the proposed project support Goal #2 of the [APLS LSTA Five-Year Plan](#) (i.e. "Support library programs, services, collections and partnerships that promote learning and literacy; serve children, youth, adults and families, including underserved populations; and enhance education, civic engagement, cultural opportunities and economic vitality of Alabama and its residents")?

Along with modernizing the information found in our adult nonfiction collection, our monthly program series will promote topics such as computer literacy and resume-building workshops. These topics would be particularly helpful to the Leeds community as 37% of the Leeds population age 16 years and older are not an employed member of the labor force, according to the U.S. Census. We believe this unemployment rate correlates with the over 12% of the local citizens who are under the poverty level. Since the majority of employers require online application submissions, this becomes an obstacle for our regular library users as many suffer from computer illiteracy, 14.3% of households do not have a computer within the home, and 25.9% of households are without broadband internet. Therefore "Current Events Café" and "Let's Get To Work" programs will encourage our library users to become better informed citizens in today's society and/or become more confident members of today's workforce.

- c. Describe how you will accomplish your goals for the project. What specific activities will be involved?

Leeds Jane Culbreth Library has a goal of assembling and offering library materials in organized collections which will provide useful information to our library users. By updating our adult nonfiction collection and biographies, the library will become more relevant to our community at large. We are compiling a list of high interest categories for readers aged 13 and up, as well as a list of popular titles

that would be essential for a robust collection. We plan to have a master list of titles by the end of September 2019.

#### 4. Project Planning:

- a. Describe the planning for this project. Provide a timeline that includes planning and implementation. **REMEMBER:** funds are not available before **October 1, 2019** and request for final payment must be requested by **June 15, 2020**.

AUGUST 2019: Compile list of printed books for the adult nonfiction collection and biographies. Once list has been reviewed by Library Director and Library Board of Trustees, we will order the books and processing materials.

SEPTEMBER/OCTOBER 2019: As books arrive, our Catalog Librarian will use the processing materials to prepare the books for circulation. The Library Director will create flyers, posters, email blasts, social media posts, and notify our local newspaper regarding the new adult nonfiction and biographies and that "Current Events Café" and "Let's Get to Work" programs will begin in 2020. The Circulation staff will be ready to shelve the books as they are processed.

NOVEMBER/DECEMBER 2019: The Library Director will coordinate a program schedule and guest speakers for "Current Events Café" throughout the 2020 calendar year. Also, the Library Director will develop the "Let's Get to Work" program curriculum and begin to take reservations of library users to participate in the first 4-6 week workshop in January.

JANUARY/MARCH/MAY/JULY/SEPTEMBER 2020: The "Let's Get to Work" 4-6 week program will begin the first Friday of January, March, May, July, and September 2020. Registered participants for "Let's Get to Work" will learn computer basic skills, resume building tips/tricks, how to dress in interview-appropriate attire, and prepare for an interview. We will highlight printed non-fiction materials in each session and encourage the participants to check them out to continue learning on their own time. Furthermore, we will guide the participants through the various online resources available through Alabama Virtual Library, such as resume assistance from Homework Help Alabama or test preparation programs from Learning Express. At the end of each of the 4-6 week programs, the registered participants will schedule a mock interview with the Library Director or fellow business members of the Leeds Chamber of Commerce. Each interviewee will be given constructive criticism at the end of the mock interview, plus a professional reference from the Library Director and a certification of completion of the "Let's Get to Work" program.

FEBRUARY/APRIL/JUNE/AUGUST/OCTOBER 2020: The bi-monthly "Current Events Café" program will be conducted in the library's meeting room for one hour. Each program will provide light snacks for those in attendance. We will cover topics that coincide with national awareness months and/or international and domestic topics of concern. Our "fake news" identification program will be scheduled for February 2020. We will discuss climate change in April 2020, in honor of Earth Day. To bring awareness to National Safety Month in June 2020, we will tackle ways to protect ourselves and humanity. We will incorporate discussions about human rights and various humanitarian efforts to reduce the amount of unintentional injury and death in our communities and beyond. National Suicide Awareness week is conducted in August 2020; therefore, our topic that month will cover mental health issues, signs of substance abuse and how to help those who need assistance. In October 2020, we will cover how to be safe online, protecting your identity, and identifying various "phishing" schemes since the holiday season will be near.

- b. Provide a list of the project personnel, their duties for this project and qualifications as they relate to the project.

Melanie Carden, Library Director - Masters of Library and Information Studies; collection development, ordering of materials from book vendors, marketing and promotion of educational

programs associated with the nonfiction collection update, liaison to Leeds City Clerk and City Council regarding LSTA grant funds

Patrick Sessions, Catalog Librarian - Masters of Library and Information Studies; cataloging and processing of materials

- c. Will there be institutional partners? What role will each of the partners play? [Complete Section J. (Partnering Libraries or Agencies) and include a letter of support from each partner.]

Tobin M. Cataldo, Executive Director of Jefferson County Library Cooperative, has supplied a letter of support. Their role will include assisting in promoting the LSTA grant, how Leeds Jane Culbreth Library will utilize the funds, and how it will improve the shared collection within the Public Libraries of Jefferson County.

- d. How will the targeted audience participate in or use this project? How will you publicize this project?

We aim to allow our library users to guide us in the types of topics that need to be added to our nonfiction collection. We will create printed flyers that detail our "Current Events Café" and "Let's Get to Work" programs that will be posted in the library. We will create Facebook and Instagram posts that describe the "Current Events Café" and "Let's Get to Work" programs. We will post the events on our library website and send articles to Leeds Tribune. We will present the programs at our bi-weekly city council meetings, which will also be on public record. We will announce these events at our monthly Chamber of Commerce luncheon.

- e. Who will provide the required local match?

The City of Leeds

- f. What will happen to the project after the funding period has ended? How will the library sustain the expanded services for library users? Will additional local funding be requested from your governmental municipality in the future based on the results of this project?

After the funding period has ended, we will continue purchasing nonfiction printed materials to ensure that our collection will remain relevant. We will evaluate the response to the "Current Events Café" and "Let's Get to Work" program to determine whether to continue offering them in the future.

### 3. Evaluation:

- a. How will you document and measure the success of this project in meeting the needs identified in #1 and the intended outcomes in #2? (i.e. number of materials circulated, number of program participants, test scores, patron feedback, etc.)

Leeds Jane Culbreth Library will prepare a report to gather data that will show how our library is currently used by evaluating the amount of people entering the library building, attending programs, asking adult reference questions, and how many items related to adult nonfiction or biographies are requested from other Jefferson County Library Cooperative locations. Additionally, we will gather feedback on how library users utilize our current collection. From this baseline report, we can gather monthly activity reports and quarterly patron feedback forms to evaluate our progress.

- b. Describe the methods that will be used to gather information and determine whether or not the library has achieved the project goals (i.e. surveys, interviews, observation, usage/circulation statistics, etc.).

Leeds Jane Culbreth Library will prepare an online survey to gather data on how our current adult nonfiction collection and biographies are used among our library users. We would like to understand our user's ability to locate necessary information for research and general knowledge inquiries. Paired with the circulation statistics from 2018 and 2019, we will create goals for the type

of increases we would like to see by the end of 2020. Two additional surveys will be submitted to library users: one in the middle of the project timeline (May 2020) and one at the end of the project timeline (November 2020). From those results, we hope to gather a response on how the updated adult nonfiction and biographies have been used and if they have helped create a dialog between our targeted group regarding issues and topics within their daily lives.

- c. How will you illustrate whether the project reached or moved toward the intended outcomes? What changes are expected in the target audience’s behavior, attitudes, skills, knowledge, status or life condition?

Leeds Jane Culbreth Library plans to see a high circulation of adult nonfiction and biographies. We are expecting more usage from those who attend the "Current Events Café" program and "Let's Get to Work" program. We believe that those who attend the "Current Events Café" will continue to check out materials regarding current events and have thoughtful discussions with fellow citizens and family members. Also, we believe that those who complete the 4-6 week "Let's Get to Work" program will gain the communication and basic occupational skills needed to acquire employment and, in turn, lower the overall poverty rate for Leeds, Alabama.

**G. BUDGET INFORMATION:** Enter the totals for each category in Section B. (Budget Summary) on page 1. **Round all figures to the nearest dollar.** (Attach additional pages if needed.)

- 1. Salaries: Project-related salaries may be used for 25% of required local match amount.

PROJECT-RELATED TASKS	LSTA FUNDS	LOCAL MATCH	TOTAL FUNDS
		\$	\$
		\$	\$
		\$	\$
		\$	\$
		\$	\$
TOTALS		\$	\$

- 2. Travel: All LSTA eligible travel must be directly related to furthering the purpose of the project.

TRIPS FROM/TO	LSTA FUNDS	LOCAL MATCH	TOTAL FUNDS
	\$	\$	\$
	\$	\$	\$
	\$	\$	\$
	\$	\$	\$
	\$	\$	\$
TOTALS	\$	\$	\$

- 3. Equipment: Describe all equipment (including hardware and software) to be purchased for the project. **[NOTE: If an individual item costs \$5,000 or more, its technical specifications must be attached to the signature page.]**



**FY2020 LSTA COLLECTION DEVELOPMENT GRANT APPLICATION**

121

EQUIPMENT ITEMS	LSTA FUNDS	LOCAL MATCH	TOTAL FUNDS
	\$	\$	\$
	\$	\$	\$
	\$	\$	\$
	\$	\$	\$
	\$	\$	\$
<b>TOTALS</b>	\$	\$	\$

4. Supplies: Include all supplies to be purchased for the project.

SUPPLY ITEMS	LSTA FUNDS	LOCAL MATCH	TOTAL FUNDS
Barcode Labels - 1000/pkg	\$150.00	\$50.00	\$200.00
Label Protectors - 250/roll	\$60.00	\$20.00	\$80.00
Bookplates - 102/pkg	\$110.00	\$30.00	\$140.00
Book Covers - variety	\$370.00	\$130.00	\$500.00
	\$	\$	\$
<b>TOTALS</b>	\$750.00	\$250.00	\$1,000.00

5. Contractual: Contractual includes services from a company or agency, such as training.

SERVICES PROVIDED	LSTA FUNDS	LOCAL MATCH	TOTAL FUNDS
	\$	\$	\$
	\$	\$	\$
	\$	\$	\$
	\$	\$	\$
	\$	\$	\$
<b>TOTALS</b>	\$	\$	\$

6. Library Materials: List by subject and format categories. Costs may include preprocessing packets.

MATERIAL TYPES	LSTA FUNDS	LOCAL MATCH	TOTAL FUNDS
Nonfiction Books - regular print	\$7,500.00	\$2,500.00	\$10,000.00
Nonfiction Books - large print	\$1,500.00	\$500.00	\$2,000.00
Biographies - regular print	\$3,750.00	\$1,250.00	\$5,000.00
Biographies - large print	\$1,500.00	\$500.00	\$2,000.00
	\$	\$	\$
<b>TOTALS</b>	\$14,250.00	\$4,750.00	\$19,000.00

**FY2020 LSTA COLLECTION DEVELOPMENT GRANT APPLICATION**

122

**CHILDREN'S INTERNET PROTECTION ACT: All applicants must answer the following question:**

Will federal funds be used in this project 1) to purchase computers used by a public library or a public school library to access the Internet or 2) to pay for direct costs associated with a public library or a public school library accessing the Internet?

Yes       No

**I. COLLECTION DEVELOPMENT:**

Enter the regular **local funds** for library materials in FY2017 and FY2018, and enter the projected regular local funds for library materials for FY2019 and FY2020.

FY2017: \$12,000.00      FY2018: \$12,000.00      FY2019: \$12,000.00      FY2020: \$12,000.00

Present collection size (use the materials definitions used for your annual APLS statistical report):

**Printed book volumes:** 29566      **Audio/visual materials:** 4899      **E-materials:** 22962 (shared-JCLC)

**J. LETTERS FROM SYSTEM OR NETWORK DIRECTORS:** Required only for members of public library systems and/or cooperative library networks (see the instructions).

—Check this box to indicate that copies of the letter(s) if required above have been attached to the signature page.

**K. PARTNERING LIBRARIES OR AGENCIES:** If you are partnering with one or more libraries or agencies, enter the number below. If not, skip this section.

Number	Type or Kind	Number	Type or Kind
	Public Libraries		Academic/College
	Schools		Other

List all partnering agencies, including the name, address and phone number of each:  
(Attach additional pages if needed.)

Name	Address	Phone Number
		(    )    -
		(    )    -
		(    )    -
		(    )    -
		(    )    -

Attach their endorsement letters to the signature page.

—Check this box to indicate that copies of the letter(s) if required above have been attached to the signature page.

**FY2020 LSTA COLLECTION DEVELOPMENT GRANT APPLICATION**

123

applicable, (1) show how cash-sharing arrangements and formulas were developed, and (2) show the anticipated budget expenditures by each library or agency:

**L. STATE AID COMPLIANCE CHECKLIST:**

- Current State Aid contract on file at APLS
- Current by-laws on file at APLS
- Current policy and procedures manual on file at APLS
- Current list of Board of Trustees on file at APLS
- Current Five-Year Plan on file at APLS
- Current statistical report on file at APLS
- Current audit or financial statement on file at APLS

FY2020 LSTA COLLECTION DEVELOPMENT GRANT APPLICATION

124

**AUTHORIZATION OF REQUEST:** We, the undersigned, (1) understand the conditions and requirements set forth in the "Federal Public Library Programs" section of the Alabama Public Library Service Administrative Code effective January 24, 2019, (2) on behalf of the state agency or city and/or county governments which support this library, agree to adhere to them, and (3) certify that this application has been approved by the Board of Trustees of the Library or, if a library agency or department, by the appropriate governing authority. We understand the following conditions:

- Failure to include required information in the application or failure to submit any required attachments with the signed signature page of the application may cause the application to not be funded.
- To be **on time** the application(s) must be submitted **by email** to [kralya@apls.state.al.us](mailto:kralya@apls.state.al.us) by **April 8, 2019** **and** one (1) paper application with original signatures and any attachments **must also** be submitted (postmark deadline: **April 8, 2019**). Send to: LSTA Grants, 6030 Monticello Dr., Montgomery, AL 36130. **A faxed signature page or attachments shall not be accepted.**

Library: Leeds Jane Culbreth Library

Grant Program: Collection Development

(Signed) Melanie A. Carden  
Project administrator

4/1/19  
Date

Printed Name: Melanie A. Carden

(Signed) Melanie A. Carden  
Library director

4/1/19  
Date

Printed Name: Melanie A. Carden

(Signed) Toushi Arbitelle  
Governmental official authorized to receive  
and disburse funds, if different from the above

04-01-19  
Date

Printed Name: Toushi Arbitelle

(Signed) Michael J Woodall  
Chair or Vice-Chair, Board of Trustees

4/1/19  
Date

Printed Name: Michael Woodall



2100 Park Place  
Birmingham, AL 35203  
205.226.3615  
PublicLibrariesInJC.org

March 26, 2019

APLS LSTA Advisory Committee  
Alabama Public Library Service  
6030 Monticello Drive  
Montgomery, AL 36130

RE: FY 2020 LSTA Application for Leeds Jane Culbreath Library

To Whom It May Concern:

After reviewing the FY2020 LSTA proposal from Leeds Jane Culbreath Library, I am happy to offer my full support for their application for funding for non-fiction collection development support.

Leeds Jane Culbreath Library is a respected member of the Jefferson County Library Cooperative, and the staff at Leeds Jane Culbreath Library, as evidenced through choices made in this grant application, have demonstrated a commitment to responding to observed community need as well as proactively identifying areas where library service can be enhanced.

Goal 2 of the APLS LSTA Five Year plan is in part to support library programs, services, collections and partnerships that promote learning and literacy; serve children, youth, adults and families. Stakeholder input gathered during the formation of the APLS LSTA Five Year plan supports investment in collection development as sound policy: 50% of respondents agreed that book collections are in the top 10 most impactful LSTA-supported services. The IMLS focal area for Information Access supports collection development in libraries (2f) as an identified goal-based project.

From the perspective of the Jefferson County Library Cooperative, this proposal is equally valuable in that a strong circulating collection not only benefits Leeds Jane Culbreath Library, but all of the member libraries through access and resource sharing. Collaboration, including cooperative collection development, and resource sharing are central tenets of the Jefferson County Library Cooperative.

Sincerely,

A handwritten signature in black ink, appearing to read "T.M. Cataldo", is written over a light blue horizontal line.

Tobin M. Cataldo  
Executive Director  
Jefferson County Library Cooperative

**Item Attachment Documents:**

19. Resolution 2019-12-04 (Carried over from the canceled meeting - December 16, 2019)  
Consider Authorizing and Approving Supplemental Insurance Benefits for City Career Firefighters  
  
Alabama First Respondents Benefit Program - Mandated by State Law - Budget Adjustment  
(No New Funds Requested - General Fund)

# CITY OF LEEDS

RESOLUTION NO. 2019-12-04

## AUTHORIZING AND APPROVING SUPPLEMENTAL INSURANCE BENEFITS FOR CITY CAREER FIREFIGHTERS

**WHEREAS**, Act 2019-361 was passed by the State Legislature and ultimately signed into law by the Governor on June 4, 2019 and is due to go into effect on January 1, 2020; and

**WHEREAS**, the new law mandates that all local governments provide supplemental cancer insurance to career firefighters who have served the City for a minimum of 12 consecutive months; and

**WHEREAS**, the Alabama First Responders Benefits Program has created a proposal to local governmental entities to comply with the State legislative mandate, and the subject insurance will be ultimately provided by the Hartford; and

**WHEREAS**, in order for the City employees to be allowed such coverage the Council is required to approve one of the proposed coverage options as an added benefit for the eligible employees.

**NOW, THEREFORE BE IT RESOLVED BY THE CITY COUNCIL OF THE CITY OF LEEDS, ALABAMA, SUBJECT AND PURSUANT TO THE REQUIREMENTS OF 2019-361, AS FOLLOWS:**

1. The above Recitals are true and correct and included herein as if fully set forth.
2. The City Council hereby finds it to be in the best interest of the City to authorize and approve the attached application and proposal presented by the Alabama First Responders Benefits Program as the administrator for a cancer insurance policy which is designed by The Hartford to meet the requirements of Ala. Act 2019-361 for the benefit of eligible City firefighters.
3. The City hereby approves the [**“Basic Plan”** (\$186.48/firefighter/annually)], [**“Enhanced Plan”** (\$198.24/firefighter/annually)] as presented by and subject to the attached proposal and plan details.
4. The Mayor, City staff, and City Attorneys shall have the full authority to do those things, perform those functions, and to sign necessary documentation in order to carry out the actions so authorized herein.

**APPROVED AND ADOPTED** at a regular meeting of the City Council of the City of Leeds, Alabama on this the 6<sup>th</sup> day of January 2020

**AYES:** \_\_\_\_\_  
**NAYS:** \_\_\_\_\_  
**ABSENT FROM VOTING:** \_\_\_\_\_  
**ABSTAIN:** \_\_\_\_\_

**CITY OF LEEDS, ALABAMA**

\_\_\_\_\_  
David Miller, MAYOR

\_\_\_\_\_  
DATE

**ATTEST:**

\_\_\_\_\_  
Toushi Arbitelle, City Clerk

In my capacity as the City Clerk of the City of Leeds, hereby certify that the above Resolution was duly adopted by the City Council of the City of Leeds at a regular meeting held on the 6th day of January 2020

\_\_\_\_\_  
City Clerk



# ALABAMA FIRST RESPONDERS BENEFITS PROGRAM

1 (800) 23 – CANCER | [Cancerinsurance@alfrp.com](mailto:Cancerinsurance@alfrp.com) | [www.alfrbp.com](http://www.alfrbp.com)



October 14<sup>th</sup>, 2019

Re: Firefighter Cancer and Disability Coverages

Dear Fire Chief,

I hope this package finds everyone in your Fire Department safe and well. As you know, Governor Ivey signed a new law in May of 2019 that will be effective on January 1, 2020. This new law mandates that all Fire Departments throughout the state of Alabama provide cancer and disability coverage for their Firefighters, based on certain categories in which they fall. All Career Paid Firefighters within the state of Alabama will be provided cancer and disability coverage at no cost to the Firefighter, effective January 1, 2020. The new law mandates that a public entity secure and pay for coverage for Career Paid Firefighters. In addition, the new law creates the option to provide cancer and disability insurance for Volunteer Firefighters, on a *department paid basis*, or *individual Firefighter paid basis*. In this package, we have provided information to help you evaluate and determine what is necessary to cover your Firefighters in your department.

Enclosed you will find information on the **Alabama First Responders Benefits Program (FRBP)**, the only endorsed product by the *Alabama League of Municipalities* for public entities in the state of Alabama. The state association, *The Alabama League of Municipalities*, was instrumental in working with politicians and other stakeholders in drafting and passing this bill. Please allow me to summarize the contents of this packet, so we may help you determine what is necessary for your department, and the coverages and costs for your department.

- The first document is a two page "**Benefits Summary Sheet**" from the *Alabama First Responders Benefits Program*, outlining the basic coverages for cancer and disability for Firefighters. This is a basic summary and would be a great document for you to share with any Firefighters in your department that have interest or would like to see more information about the program.
- The second document enclosed in this package is a "**Sample Rating Sheet**." This is a sample document for you to utilize to determine the cost of cancer and long-term disability coverage for your Firefighters under the new law. As you look at that sample rating sheet, you will find on the left-hand side in green "**Option 1 Basic Plan**." The *basic plan* provides coverage to meet all of the mandated minimum requirements under the state law. For example, there are 21 named cancers under this new law, and the *basic plan* covers those 21 cancers. On the right-hand side of this document in gold, you will find information in reference to "**Option 2 Enhanced Plan**." The *enhanced plan* is a step above the *basic plan*, and provides additional coverages for all cancers, not just the basic 21 cancers. On the sample rating sheet, simply plug in the number of Paid Firefighters, Certified Volunteer Firefighters, and Non-Certified Volunteer Firefighters, and you will be able to calculate the total cost for your department for the year. Please be cautious and notice that there are rates at the top for **\*employer paid plans\*** and rates at the bottom for **\*individual paid plans\***. For those departments such as a Volunteer Fire Department, if that Volunteer Department does not pay for the entire Firefighting team that qualifies for the program, those Firefighters can individually pay for this coverage, but the rates change. The reason for the change in rates is that it is no longer a group policy, but becomes an individual policy. Group plans, as you know, always get a reduced rate. At the bottom of this sample rating sheet you will find information that you need to read before calculating the cost for your department. On the sample rating sheet, you will also find our dedicated phone number and email address. If you have any questions, please do not hesitate to give us a call or

OVER



send us an email, and we will be happy to discuss the rates and help you calculate your estimated annual cost for your Fire Department.

- The third document enclosed is a **two page flyer** titled “Alabama Firefighters Have an Occupational Risk. We Have Their Back.” This flyer was created by *Hartford Insurance Company* to summarize and outline the coverages and services of this program. As previously stated, Hartford Insurance Company is the insurance carrier that will issue the policy for this program through the *Alabama First Responders Benefits Program*. On this flyer, you will also find our dedicated phone number and email address, along with our website [www.alfrbp.com](http://www.alfrbp.com). You may find all of the enclosed documents, as well as additional resources under the resources section of our website.
- The fourth document enclosed is a six page document containing “**Frequently Asked Questions.**” Over the last several weeks, many Public Entities, Fire Departments, Firefighters, Fire Chiefs, etc., have asked specific questions regarding coverages and benefits under this program. We have created this document to provide those frequently asked questions and answers to your department as well. This document was updated on October 11, 2019. This would be a great document to share with the Firefighters in your Fire Department as well.
- The last document enclosed in this package is the **Press Release** that was issued on September 26<sup>th</sup>. This document outlines more specific details regarding the program, the rates for the various categories, as well as additional information about *Alabama First Responders Benefits Program*.

If you have any questions, or need any assistance, we are here to help. We have a dedicated team standing by to help you in any way that you need. Please do not hesitate to contact us.

**Dedicated Toll Free Customer Service: 1 (800) 23 - CANCER**

**Dedicated Email:** [cancerinsurance@alfrbp.com](mailto:cancerinsurance@alfrbp.com)

In addition, our new website for the *Alabama First Responders Benefits Program* is live. You may find all of the enclosed documents as well as additional resources under the resources section of our website: [www.alfrbp.com](http://www.alfrbp.com).

Lastly, if you would like to receive an official quote, please send an email to [cancerinsurance@alfrbp.com](mailto:cancerinsurance@alfrbp.com) and request a quote form. We will send you a spreadsheet for you to simply list your Firefighters with some basic information and email it back to us. We will upload your spreadsheet into our quoting and rating system, and provide you with an official quote.

We appreciate the opportunity to serve and support you, your Fire Department, and all Firefighters on your team. If you have any questions or if there is anything that we can help you with, please do not hesitate to give us a call.

Thank you,



**Terry E. Young – CRM CWcHP CRE**

*President, First Responders Benefits Program*

*Chairman of the Board, Kowaliga Volunteer Fire Department*

[Terry@alfrbp.com](mailto:Terry@alfrbp.com) | 1 (800) 23 – CANCER | [www.alfrbp.com](http://www.alfrbp.com)



# Alabama First Responders Benefits Program

## BENEFITS SUMMARY SHEET

Firefighters are local heroes to the communities they serve. The Alabama First Responders Benefits Program was created for cities and counties within the State of Alabama, and will help take care of our 20,000 Firefighters and their families. Coverage provided by Hartford Insurance Company will meet the legislative mandates as follows:

### Lump Sum Benefit

#### ***Firefighter Eligibility Based on Legislation:***

- Paid Firefighters – 12 months of consecutive service
- Certified Volunteers – 12 months of consecutive service
- Non-Certified Volunteers – 12 months of consecutive service

#### ***Covered Cancers Based on Legislation:***

"Includes bladder, blood, brain, breast, cervical, esophageal, intestinal, kidney, lymphatic, lung, prostate, rectum, respiratory tract, skin, testicular, and thyroid cancer, leukemia, multiple myeloma, Hodgkin's lymphoma, and non-Hodgkin's lymphoma."

LUMP SUM CANCER PLAN	BENEFIT
Cancer Benefit Amount	\$25,000
Invasive Cancer	100% of Coverage Amount
Non-Invasive Cancer	25% of Coverage Amount
Coverage Maximum (% of Coverage Amount)	Firefighter: 200% (2 x \$25,000)
Recurrence Benefit (% of Coverage Amount)	100%; 90 Days Separation Period
Benefit Portability	Yes

## Long Term Disability (LTD)

### **Eligibility Based on Legislation:**

Paid Firefighters – 12 months of consecutive service

Certified Volunteers – 12 months of consecutive service

Non-certified Volunteers – 12 months of consecutive service

### **Covered Cancers Based on Legislation:**

"Includes bladder, blood, brain, breast, cervical, esophageal, intestinal, kidney, lymphatic, lung, prostate, rectum, respiratory tract, skin, testicular, and thyroid cancer, leukemia, multiple myeloma, Hodgkin's lymphoma, and non-Hodgkin's lymphoma."

LTD CANCER PLAN	BENEFIT	ELIMINATION PERIOD
Active Firefighter	\$3,000	180 Days
Volunteer Certified Firefighter	\$3,000	180 Days
Volunteer Non-Certified Firefighter	\$1,500	180 Days
Benefit Duration	3 Years	
Definition of Disability	3 Years Own Occupation	
Pre-Ex	ER Paid: No Pre-Ex Firefighter Paid: 3/12	
Continuation	Included	

## CONTACT US

**Program Email:** [Cancerinsurance@alfrbp.com](mailto:Cancerinsurance@alfrbp.com)

**Program Toll-Free Call Center:** 1 (800) 23 – CANCER

**\*\*Please see full policy and/or Firefighter Cancer/Disability Booklet for all coverage benefits and details.**

*The Alabama First Responders Benefits Program "the Program" is provided by the Alabama First Responders Benefits Association. Program rates are subject to review and approval by the Alabama Department of Insurance. Consequently, the Program will not take effect until the Alabama Department of Insurance approves. Actual Program benefits, rates, terms, and conditions are subject to change based on regulatory requirements and changes in employer operations or information. This proposal does not include all of the policy terms, conditions, limitations, and exclusions, which provide the full detail of coverages and take precedence over this proposal.*

Sample Rating Sheet

**ALABAMA FIRST RESPONDERS BENEFITS PROGRAM  
FIRE DEPARTMENT LTD & CANCER INSURANCE COVERAGE OPTIONS**

Toll Free: 1 (800) 23 - CANCER

Email: [Cancerinsurance@alfrbp.com](mailto:Cancerinsurance@alfrbp.com)

**OPTION 1 - BASIC PLAN**

**Basic Plan: LTD & Cancer Insurance - Lump Sum \*EMPLOYER PAID\***

# Paid Firefighters \_\_\_\_\_ x \$186.48 = \_\_\_\_\_ Total Cost Per Yr  
 # Certified Vol. Firefighters \_\_\_\_\_ x \$186.48 = \_\_\_\_\_ Total Cost Per Yr  
 # Non Certified Vol. Firefighters \_\_\_\_\_ x \$138.48 = \_\_\_\_\_ Total Cost Per Yr

**Total Cost Above for Basic Plan \*EMPLOYER PAID\* For the Yr = \$ \_\_\_\_\_**

**\*\* 90% of All Departments Will Fall in Above Basic Plan or Enhanced Plan Categories**

**\*\* PLEASE NOTE: Rates in Below Section Are \*Individually\* Paid by the Firefighter**

**Basic Plan: LTD & Cancer Insurance - Lump Sum \*INDIVIDUAL PAID\***

# Certified Vol. Firefighters \_\_\_\_\_ x \$316.92 = \_\_\_\_\_ Total Cost Per Yr  
 # Non Certified Vol. Firefighters \_\_\_\_\_ x \$214.92 = \_\_\_\_\_ Total Cost Per Yr

**OPTION 2 - ENHANCED PLAN**

**Enhanced Plan: LTD & Cancer Insurance - Lump Sum \*EMPLOYER PAID\***

# Paid Firefighters \_\_\_\_\_ x \$198.24 = \_\_\_\_\_ Total Cost Per Yr  
 # Certified Vol. Firefighters \_\_\_\_\_ x \$198.24 = \_\_\_\_\_ Total Cost Per Yr  
 # Non Certified Vol. Firefighters \_\_\_\_\_ x \$150.24 = \_\_\_\_\_ Total Cost Per Yr

**Total Cost Above for Enhanced Plan \*EMPLOYER PAID\* For the Yr = \$ \_\_\_\_\_**

**Enhanced Plan: LTD & Cancer Insurance - Lump Sum \*INDIVIDUAL PAID\***

# Certified Vol. Firefighters \_\_\_\_\_ x \$332.08 = \_\_\_\_\_ Total Cost Per Yr  
 # Non Certified Vol. Firefighters \_\_\_\_\_ x \$230.08 = \_\_\_\_\_ Total Cost Per Yr

Option 1 Basic Plan: Includes 21 Cancers Required by New Law

Option 2 Enhanced Plan: Includes All Cancers (21 Required by Law + All Other Cancers)

\*PLEASE NOTE: Top Categories are Employer Paid Plans

\*PLEASE NOTE: Bottom Categories are Individual Firefighter Paid Plans

Option 1 & 2 \*Employer Paid Plans\*: Can Include A Mix of Paid, Volunteer, & Certified Firefighters All On Same Policy

LTD: Long Term Disability

Rates Are Total Cost Per Firefighter, Per Year, for Both Cancer Coverage & Long Term Disability (LTD) Coverage

Same Rates For Paid Firefighters & Certified Volunteer Firefighters Under \*Employer Paid\* Plans

Rates For Non Certified Volunteer Firefighters Under \*Employer Paid\* Plans are Less, Due to Disability Benefit Being Reduced from \$3,000 to \$1,500 Per Month, Per the Law

Rates for \*Individually Paid\* Volunteer Firefighters are Higher, Due To The Fact They Are Not Group Rates, and All Firefighters Are Not Being Provided Coverage

The Alabama First Responders Benefits Program "the Program" is provided by the Alabama First Responders Benefits Association. Program rates are subject to review and approval by the Alabama Department of Insurance. Consequently, the Program will not take effect until the Alabama Department of Insurance approves. Actual Program benefits, rates, terms and conditions are subject to change based on regulatory requirements and changes in employer operations or information. This proposal does not include all of the policy terms, conditions, limitations, and exclusions which provide the full detail of coverages and take precedence over this proposal.



# ALABAMA FIREFIGHTERS HAVE AN OCCUPATIONAL RISK. WE HAVE THEIR BACK.



It's a well-known fact that certain types of cancer are an occupational health risk for firefighters. With that diagnosis comes major costs.

Now there's a way to help protect those who protect us: **The Alabama First Responders Benefits Program.** It provides coverage and support crucial to your firefighters and their families should cancer strike.

And it's from a carrier known for its steadfast commitment to fire prevention and protection for more than 200 years: The Hartford.



**The Alabama First Responders Benefits Program**

1-800-23-CANCER  
cancerinsurance@alfrbp.com  
www.alfrbp.com

## DESIGNED BY FIREFIGHTERS FOR FIREFIGHTERS

Firefighters are local heroes to the communities they serve. That's why we've created a program that helps take care of firefighters and their families.

Thanks to guidance and feedback from the Alabama League of Municipalities, we're now able to be there for Alabama's firefighters in their time of need, just as they are for us every single day.

The Hartford is committed not only to fire prevention, but also to the well-being of Alabama's firefighters through information and education. At the same time, The Hartford offers another level of support and service for your firefighters.

### Our program can help municipalities:

- Promote recruitment and retention
- Improve the health and effectiveness of firefighters through information and education
- Send a message, loud and clear, of support and service for your firefighters

## FIRE PREVENTION HAS BEEN THE HARTFORD'S CORNERSTONE SINCE 1810

### Heroes in our history.

After a fire destroyed New York City's financial district in 1835, the president of The Hartford, Eliphalet Terry, and his board of directors pledged their personal fortunes to help pay the claims.



## HELPING KIDS BECOME EVERYDAY HEROES

To teach schoolkids the basics in fire safety, we founded the Junior Fire Marshal® program in 1947. Kids who complete the program gain knowledge that can save lives.



**THE HARTFORD**

## WHY THE HARTFORD?

**A commitment to deliver value through:**Innovation Leadership Support 

## WHY ALABAMA FIREFIGHTERS?

**A commitment to deliver value through:**Unity Excellence Information **A CUSTOMER EXPERIENCE THAT'S WON A THUMBS UP FROM 94%<sup>1</sup>**

The Hartford treats every customer's time as a precious commodity, simplifying our processes while giving you more choices and flexibility. At every step, you'll find open doors and open minds instead of obstacles.

Here are a few examples:

- Dedicated claims number for Alabama Firefighter claims
- Simplified eligibility confirmation with The Hartford's program

**PROTECTION THAT EMPOWERS FIREFIGHTERS TO FIGHT BACK****Who's eligible?**

All firefighters must have at least 12 months of consecutive service.

- Paid firefighters
- Certified volunteers
- Non-certified volunteers

**What types of cancer are covered under the legislation?**

Cancers affecting the bladder, blood, brain, breast, cervical, esophageal, intestinal, kidney, lymphatic, lung, prostate, rectum, respiratory tract, skin, testicular, and thyroid cancer, leukemia, multiple myeloma, Hodgkin's lymphoma, and non-Hodgkin's lymphoma.

**COVERAGE AMOUNTS FOR CANCER****Critical illness insurance**

- As stated in the legislation, \$25,000 per diagnosis for invasive cancer; \$6,250 per diagnosis for non-invasive cancer
- 2x recurrence; 200% max (\$50,000)
  - Base Plan: Covers legislated cancers
  - Enhanced Plan: Covers ALL cancers

- Salaried Firefighters: Mandated, employer paid
- Certified Volunteer Firefighters: Can be employer paid or individual paid
- Non-Certified Volunteer Firefighters: Can be employer paid or individual paid

**Long-term Disability insurance**

- As stated in the legislation, 180-day elimination period; 36-month duration; 3-year own occupation definition of disability
- Salaried Firefighters: Flat \$3,000 monthly benefit. Mandated, employer paid
- Certified Volunteer Firefighters: Flat \$3,000 monthly benefit. Can be employer paid or individual paid
- Non-Certified Volunteer Firefighters: Flat \$1,500 monthly benefit. Can be employer paid or individual paid

**A TOOLKIT THAT CONVINCES, ENGAGES AND EDUCATES**

Long recognized in the industry for superior education, The Hartford is proud to offer materials on:

**Benefit awareness:**

- A self-service email on the benefit and The Hartford
- A flyer on key information

**Claims process:** A how-to email and poster on filing a claim

**Cancer awareness and prevention:**

A brochure on cancer risks and prevention

**CONTACT US - 1-800-23-CANCER | [cancerinsurance@alfrbp.com](mailto:cancerinsurance@alfrbp.com)**

**GIVE FIREFIGHTERS A CRUCIAL SAFETY NET. GET A QUOTE TODAY.**

Go to [www.alfrbp.com](http://www.alfrbp.com)



The Hartford is The Hartford Financial Services Group, Inc. and its subsidiaries, including underwriting company Hartford Life and Accident Insurance Company. Home Office is Hartford, CT. All benefits are subject to the terms and conditions of the policy. Policies underwritten by the underwriting company listed above detail exclusions, limitations, reduction of benefits and terms under which the policies may be continued in force or discontinued. © 2019 The Hartford.

**THE CRITICAL ILLNESS POLICY PROVIDES LIMITED BENEFITS FOR SPECIFIED DISEASES ONLY.** This limited health benefit plan (1) does not constitute major medical coverage, and (2) does not satisfy the individual mandate of the Affordable Care Act (ACA) because the coverage does not meet the requirements of minimum essential coverage.

Critical Illness Form Series includes GBD-2600, GBD-2700. Disability Form Series includes GBD-1000, GBD-1200, or state equivalent.

Policy Number: 681675

<sup>1</sup> Percentage represents unweighted combination of LTD and STD claimant responses of "completely" or "mostly" satisfied. Gfk Claimant Satisfaction Survey, 2018.

7521a NS 09/19



# Alabama First Responders Benefits Program

## Frequently Asked Questions

**Q: When does the new law take effect? When will the insurance program be effective?**

*The new law signed by the governor will take effect on January 1, 2020. All insurance coverages with Alabama First Responders Benefits Program (FRBP) will take effect on January 1, 2020 as well.*

**Q: Who is the insurance carrier for this program?**

*Hartford Insurance Company has implemented similar programs in multiple other states. Hartford Insurance Company was chosen in conjunction with several decision-makers, with the endorsement of the Alabama League of Municipalities. Hartford Insurance Company will be the Insurance carrier for this program in Alabama.*

**Q: How can I obtain more information about this program?**

*Alabama First Responders Benefits Program (FRBP) was organized to oversee and implement the new Firefighter Cancer and Disability Insurance Program in the State of Alabama. Alabama First Responders Benefits Program has a dedicated team that is here to serve you and answer any questions you have about this program. You can reach a member of our team at our dedicated phone number: **1 (800) 23 - CANCER**. You can also reach a member of our team at our dedicated email address: [cancerinsurance@alfrbp.com](mailto:cancerinsurance@alfrbp.com). Effective October 1, 2019, First Responders Benefits Program will send out weekly emails with more information on the program, services, etc.*

**Q: How can I obtain the pricing for this program for our Firefighters and Departments?**

*On Friday, September 20th, an email blast was sent to over 4,000 contacts in the Firefighting Industry in the State of Alabama. This email included the tentative rates for Career Firefighters and Volunteer Firefighters. The rates were tentative, subject to final approval from the Department of Insurance. We do not foresee any significant changes in the rates, but until the Department of Insurance approves the rates, they must be declared tentative. The rates will be posted on our website once approved by the Department of Insurance.*

**Q: How can our Public Entity or Department ensure we continue to obtain new information about the program as it becomes available?**

*Please send an email to [Terry@alfrbp.com](mailto:Terry@alfrbp.com) to request that your email be added to our distribution list. Your email will be added within 24 hours of your request. Please feel free to submit as many different email addresses with Department Personnel that need to receive this information.*

**Q: How can I obtain printed materials on this program to review and share with our Firefighters and decision-makers?**

*We will be sending a USPS package in a bright red envelope to all Fire Chiefs in all paid fire Departments throughout the State of Alabama within the next 10 - 14 days. Due to lack of address information for Volunteer Departments, the number of correct mailing addresses we have for Volunteer Departments is limited. If you are a Volunteer Department, and would like to have a packet of information mailed to you, please send us an email to [Terry@alfrbp.com](mailto:Terry@alfrbp.com) with your mailing address, and request to be added to our mailing list.*

**Q: How can I get a quote for the cancer and disability coverage for our Firefighters in our Department?**

*Please contact FRBP at 1 (800) 23 - CANCER or [cancerinsurance@alfrbp.com](mailto:cancerinsurance@alfrbp.com) and one of our dedicated team members will provide you with a template spreadsheet for you to list your Active Firefighters/Roster so we can provide you with an actual quote. This template spreadsheet will be available via email using Microsoft Excel, or via the FRBP website as a downloadable document.*

**Q: If our Department has both Paid and Volunteer Firefighters, will we be able to get coverage for both?**

*If your Department has paid Firefighters, Certified Volunteer Firefighters, or Non-Certified Volunteer Firefighters, you will be able to get a quote covering all Firefighters in all three different categories under one plan for your Department.*

**Q: Can retired Firefighters be covered under this plan?**

*This plan will take effect on January 1, 2020. If you are an active Firefighter on January 1, 2020 and meet all other qualifications, and you retire after January 1, 2020, you have the ability to keep your coverage as a retired Firefighter. You have the option to keep your coverage and pay the rates as an individual. If you were retired as a Firefighter before this plan takes effect on January 1, 2020, as a previously retired Firefighter, you will not be eligible for this coverage.*

**Q: Can you clarify what it means by law to be an active Firefighter for 12 consecutive months?**

*Under the law, to be eligible for this coverage you must be an Active Firefighter who has completed 12 months of active service by January 1, 2020. If you are a Career Paid Firefighter, the definition of active service is pretty simple. You must be actively working, receiving a paycheck, and participating in your Fire Department for 12 consecutive months, prior to January 1, 2020.*





*If you are a Volunteer Firefighter, your Fire Department should have some form of Standard Operating Procedure (SOP). The SOP will state your specific requirements such as participate in a certain amount of training, respond to a certain number of calls, etc. Please consult your Fire Department SOP for the definition of an Active Firefighter in your Volunteer Department. If you do not have a Standard Operating Procedure as a Volunteer Department, please call 1 (800) 23 - CANCER and one of our account representatives will be happy to help you with the eligibility requirements.*

**Q: What is the cost per Firefighter for our Department?**

*Please refer to the press release from September 20th in reference to the rates for Career Firefighters and Volunteer Firefighters. The rates for Career Firefighters and Certified Volunteer Firefighters are the same rates when your Department is paying for 100% of the premiums. If you are a Career Paid Firefighter, the law mandates that your Department must pay for 100% of your premium. Under the law, if you are a Volunteer Department, it is optional as to whether or not the Volunteer Department will pay for all, or only part of the premium for Volunteer Firefighters.*

**Q: What if my Department is not going to pay my premiums and I'm a Volunteer Firefighter?**

*If you are a Certified Volunteer Firefighter or a Non-Certified Volunteer Firefighter and you meet the eligibility requirements of 12 months of consecutive service by January 1, 2020, you will be eligible to purchase coverage on an individual basis. If your Department is not paying for your entire Firefighting Team as a group, please call 1 (800) 23 - CANCER to discuss the rates if you would like to pay for the coverage individually.*

**Q: If I am diagnosed with cancer, how much will this policy pay me for my cancer diagnosis?**

*Under FRBP, there is a Lump Sum Cancer Benefit that pays \$25,000 upon diagnosis for invasive cancers. The \$25,000 benefit is payable upon diagnosis by the doctor. Under this plan, you are eligible for a maximum of \$50,000 in coverage on a lifetime basis. In other words, this policy can pay for two cancer diagnoses, totaling up to \$50,000 per lifetime.*

*\*\*Please refer to full policy for coverage details.*

**Q: What types of cancer does this insurance cover?**

*It is mandated that FRBP cover a specified list of cancers written in the law. This list contains a total of 21 cancers that are referred to as "Basic Legislated Cancers." Under FRBP, you have the option to purchase the Basic Plan, which meets the minimum standards of the law. Alternatively, you have the*

option to purchase the Enhanced Plan, which essentially covers all cancers. The Enhanced Coverage costs approximately only \$12 more per Firefighter, per year, than the Basic Plan.

*\*\*Please refer to full policy for details regarding all cancers covered under the Enhanced Plan.*

**Q: How is a Non-Invasive Cancer Diagnosis Paid?**

*Under FRBP, if you have a non-invasive cancer diagnosis, you will receive a \$6,250 payment (versus the \$25,000 payment for invasive cancers). These different diagnoses, invasive versus non-invasive, are determined by your physician according to the industry medical standards.*

*\*\*Please refer to full policy for coverage details.*

**Q: I am a Firefighter currently covered under the FRBP plan with my Department. If I retire or leave the Firefighting Industry, do I have the ability to keep my coverage?**

*If you were covered under FRBP as an Active Firefighter, and you either retire, leave the industry, or terminate your employment from your employer, you are eligible to keep coverage with you under what is referred to as Benefit Portability. You will be required to pay the annual premiums individually.*

**Q: I am a paid Firefighter and I work for one Department for the first 6 months of the year, and another Department for the last 6 months of the year. Which Department is responsible for paying for my coverage?**

*If you are an eligible Firefighter that qualified for coverage on January 1, 2020, the Department that you are working for on January 1, 2020, is the Department that is responsible for paying your premiums for the year. If you work for another Department on January 1, 2021, that new Department will be responsible for paying your premiums on this coverage for the next year, and so on.*

**Q: How does the Long-Term Disability Benefit with this program work?**

*If you are a Career Active Firefighter diagnosed with a covered cancer, and you are disabled and unable to work after the 180 day elimination period, you will be paid \$3,000 per month, for up to 36 months. If you are a Certified Volunteer Firefighter, the above disability benefits apply to you in the same way. If you are a Non-Certified Volunteer Firefighter, once you have met the 180 day elimination period, you will be eligible for \$1,500 per month, for up to 36 months.*

*\*\*Please refer to full policy for coverage details.*

**Q: I am drawing disability from other sources after I am diagnosed with a covered cancer. Do I still get the \$3,000 per month or \$1,500 per month?**

*You will need to consult one of the claims specialists at that time. This program dictates that the disability program will coordinate with other potential disability income sources. Without having specifics of an individual Firefighters other sources of disability income, it is difficult to answer this*



*question. The bottom line is this disability benefit under FRBP will coordinate and may offset with other income sources that you might have.*

**Q: Assuming this insurance program goes in effect January 1, 2020, what if I was diagnosed on December 15, 2019 with an invasive cancer, and I begin receiving treatment in January 2020 after this program took effect. Will this program pay me my lump sum cancer benefit of \$25,000?**

*This program will not pay you the \$25,000 in the above scenario. Your diagnosis of cancer must be after January 1, 2020, and you must meet all other eligibility requirements. If you are a covered Firefighter on January 1, 2020, and your diagnosis occurs on January 2, 2020, you would be covered under this plan.*

**Q: I'm a Firefighter, and I'm on military leave during the year. Upon return 12 months later, I go back to my original job. Do I lose my coverage due to military leave?**

*Generally speaking, you will not lose your coverage. There are some specific time frames and maximums on the length of time you can be away from the Firefighter employment. If that situation arises, please call 1 (800) 23 - CANCER and discuss your specific details with one of our claims specialists, and they will help you through that process.*

**Q: I work as a paid Firefighter at one Department, and a Volunteer Firefighter at another Department. Can I get coverage at both Departments and can I collect on a claim at both Departments?**

*No, you cannot get coverage at two different Departments, nor can you file a claim at both Departments. If you are a paid Firefighter receiving a paycheck and benefits at one Department, and you are a Volunteer Firefighter at another Department, your primary employer will be the paid Department. The paid Department will be responsible for paying for your coverage.*

**Q: I Volunteer at three different Departments during the year, which Department would pay for my coverage?**

*If only one of those Departments is paying for 100% of your coverage, that is the Department that you should qualify under, and that Department would be paying for your premiums. You would need to consult with the Fire Chief of that Department to ensure that you are eligible and considered as an Active Firefighter under their standard operating procedures throughout the year.*

**Q: How do I file a claim for coverage under this program?**

*Once you are determined eligible, and you are covered under a Fire Department, you will receive information by calling our dedicated claims phone number 1 (800) 574 - 5139 and our support team will help you navigate the process of filing a claim.*

Thank you,

**Terry Young**

*President*

First Responders Benefits Program

[Terry@alfrbp.com](mailto:Terry@alfrbp.com)

**CONTACT US**

**Program Email:** [Cancerinsurance@alfrbp.com](mailto:Cancerinsurance@alfrbp.com)

**Toll Free Customer Service:** 1 (800) 23 – CANCER

**Toll Free Claims Center:** 1 (800) 574 – 5139

***\*\*Please see full policy and/or Firefighter Cancer/Disability Booklet for all coverage benefits and details.***

*The Alabama First Responders Benefits Program “the Program” is provided by the Alabama First Responders Benefits Association. Program rates are subject to review and approval by the Alabama Department of Insurance. Consequently, the Program will not take effect until the Alabama Department of Insurance approves. Actual Program benefits, rates, terms, and conditions are subject to change based on regulatory requirements and changes in employer operations or information. This proposal does not include all of the policy terms, conditions, limitations, and exclusions, which provide the full detail of coverages and take precedence over this proposal.*

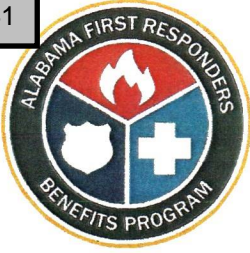

# ALABAMA FIRST RESPONDERS BENEFITS PROGRAM

## PRESS RELEASE

09/26/2019



### *"Alabama Introduces First Firefighter Cancer & Disability Insurance Program Under New Law"*

**BIRMINGHAM, ALABAMA** – The *Alabama League of Municipalities* has officially endorsed the *"First Responders Benefits Program (FRBP)."* This program will be the state wide entity delivering the new "Firefighter Cancer and Disability Insurance Program" to all Firefighters in Alabama. **FRBP** is excited to bring this product to Firefighters/First Responders and their families throughout the State of Alabama, to help protect and support them with this invaluable benefit and service.

This program will provide the Cancer and Disability Insurance to meet the guidelines and requirements of the house bill that was signed by the Governor in 2019. This bill became law, ACT 2019-361, and will be effective on January 1, 2020. This program will have two primary options. The first option will be to provide benefits that meet the "minimum requirements" of the new law. The second option will be an "enhanced product to meet all of the minimum guidelines and provide some additional benefits" to our Firefighters and First Responders, for just a few dollars more than the basic plan.

**FRBP** has received numerous calls from cities, counties, fire districts, etc., requesting information, and asking for an "indication of the projected cost" so they could build this into their finance budgets. **FRBP** has partnered with **Hartford Insurance Company**, who has delivered the same Firefighter Cancer/Disability Product throughout the U.S. to several other statewide programs. Hartford has developed the following "tentative rates" for the state of Alabama, subject to final approval of the Alabama Department of Insurance.

## TENTATIVE RATES:

### **CAREER PAID FIREFIGHTER**

If you are a "Career Paid Firefighter," the cost for the **enhanced benefit option** of cancer and long-term disability will be \$198.24 per year, per Firefighter. The cost of the **basic plan** for this same category of "Career Paid Firefighter" which meets the "minimum standards of the law" will be \$186.48 per year, per Firefighter. The primary difference in the enhanced benefit option and the basic plan is the cancer coverage. The basic plan covers the 21 named cancers, per the law. The enhanced benefit option covers all cancers. (\*\*Note: Premiums must be paid by employer for all Firefighters in this category based on the law.)

### **CERTIFIED VOLUNTEER FIREFIGHTER**

If you are a "Certified Volunteer Firefighter," the cost for the **enhanced benefit option** of cancer and long-term disability will be the same as the career paid firefighter at \$198.24 per year, per Firefighter. The cost of the **basic plan** for this same category of "Certified Volunteer Firefighter" will also be the same as the career paid firefighter at \$186.48 per year, per Firefighter. The primary difference in the enhanced benefit option and the basic plan is the cancer coverage. The basic plan covers the 21 named cancers, per the law. The enhanced benefit option covers all cancers. (\*\*Note: Premiums must be paid by employer/volunteer department for all Firefighters in this category to get these rates.)

### **NON-CERTIFIED VOLUNTEER FIREFIGHTER**

If you are a "Non-Certified Volunteer Firefighter," the cost for the **enhanced benefit option** of cancer and long-term disability will be \$150.24 per year, per Firefighter. The cost of the **basic plan** for the "Non-Certified Volunteer Firefighter" will be \$138.48 per year, per Firefighter. The primary difference in the enhanced benefit option and the basic plan is the cancer coverage. The basic plan covers the 21 named cancers, per the law. The enhanced benefit option covers all cancers. Also note that the premiums are less for this category because the monthly disability benefit for "Non-Certified Volunteer Firefighters" is LESS. (\*\*Note: Premiums must be paid by employer/volunteer department for all Firefighters in this category to get these rates.)

*The above three categories assume that the employer/department will pay for 100% of the cost of all Firefighters (Career Paid, Certified Volunteer, and Non-Certified Volunteers) in the department.*

**\*\* If there are "Volunteer Departments" in the state that will not be paying for this coverage for their Firefighting Team, please call 1 (800) 23 – CANCER for the rates for the individual paid Firefighter plans. \*\*\***

Within the next 10-14 days, we will launch the Alabama First Responders Benefits Program website that you may utilize for additional information, as well as request an online quote for your department. We have also set up the dedicated phone number and email address shown below for all questions and support during the enrollment process for your Municipality and Volunteer Departments.

#### **Dedicated Phone #:**

1 (800) 23 - CANCER

#### **Dedicated Email:**

[cancerinsurance@alfrbp.com](mailto:cancerinsurance@alfrbp.com)

In addition, we will be mailing a packet to the Fire Chiefs with product and informational literature in the next 10 to 14 days. Please be on the lookout for this information. You will receive this packet in a bright red Tyvek envelope, addressed to the Fire Chief in your department. If by some chance you do not receive this packet within the next 10 to 14 days, please give us a call so that we can make sure that we get you this informational packet to you.

Please feel free to forward this email to anyone that you feel needs to receive this information. If you have someone that needs to be added to this email list, please reply to this email and we will add them to future emails. It will be our goal going forward to communicate to you weekly on key bullets and information about this program.

In closing, it is our honor and privilege to serve the First Responders in our communities throughout the State of Alabama. You have my personal commitment that the **First Responders Benefits Program** is dedicated to support and serve you throughout this process. We have also assembled a dedicated team of people, who will be answering all calls and emails from each of you at the above dedicated 800 phone number and email address. Thank you again, and we look forward to working with you in the coming weeks.

Thank you,

**Terry E. Young**

*President*

First Responders Benefits Program

[Terry@alfrbp.com](mailto:Terry@alfrbp.com)

*Affiliate of Millennium Risk Managers, LLC*

The Alabama First Responders Benefits Program "the Program" is provided by the Alabama First Responders Benefits Association. Program rates are subject to review and approval by the Alabama Department of Insurance. Consequently, the Program will not take effect until the Alabama Department of Insurance approves. Actual Program benefits, rates, terms, and conditions are subject to change based on regulatory requirements and changes in employer operations or information. This proposal does not include all of the policy terms, conditions, limitations, and exclusions, which provide the full detail of coverages and take precedence over this proposal.

**Item Attachment Documents:**

20. Ordinance 2020-01-01 Consider Determination of Assenting to the Rezoning at 1730 Jones Street (Site address only)

# NOTICE OF PUBLIC HEARING

City of Leeds  
City Council  
Application for Rezoning

## APPLICATION

An application has been filed with the City of Leeds requesting the **Rezoning** of a certain parcel of property from R-2 Single Family Residential District to R-5, Garden Home District.

## City Council

The City Council makes the final determination of this request for rezoning. Appeals to the decision of the City Council are made to Circuit Court of (in this instance) Jefferson County and St. Clair Co.

<b>CASE #:</b>	<b>Z-2019-008</b>
<b>APPLICANT NAME:</b>	<b>MICHAEL MYRICK &amp; JANIE MYRICK</b>
<b>PROPERTY OWNER:</b>	<b>MYRICK JACK A JR &amp; JANIE P; MYRICK MICHAEL G ETAL</b>
<b>TAX PARCEL ID:</b>	<b>2605161001037000; 2605161001042000; 2605161001040000; 2500164001001.000</b>
<b>SITE ADDRESS:</b>	<b>1730 Jones St., Leeds, AL 35094 – Site Only Jefferson CO &amp; St. Clair Co</b>
<b>CURRENT ZONING:</b>	<b>R-2, SINGLE FAMILY RESIDENTIAL DISTRICT</b>

**NOTICE IS HEREBY GIVEN** that the City Council will hold a public hearing on the proposed rezoning request.

The hearing is scheduled on

**Date:** Monday, January 6, 2020  
**Time:** 6:00 pm  
**Place:** Leeds Civic Center Meeting Room  
1000 Park Drive  
Leeds, AL 35094

**Public Information:** Any interested persons or their representative may appear at the meeting and comment on the application. **Comments are limited to two (2) minutes.** All comments should be directed to the council and please refrain from repeating statements made by previous speakers. Written comments may be mailed or emailed to the Council.

For more information about the application and related issues or to schedule an appointment:

**Contact Person:** Brad Watson  
**E-mail:** bwatson@leedsalabama.gov  
**Phone:** (205) 699-0907  
**Mailing Address:** Leeds City Council – Rezoning Case Z-2019-008  
% Development Services  
1404 9<sup>th</sup> Street  
Leeds, Al 35094



**ORDINANCE NO. 2020-01-01**

**ORDINANCE ASSENTING TO THE REZONING OF CERTAIN PROPERTY OR PARCEL FROM R-2, SINGLE FAMILY DISTRICT TO R-5, GARDEN HOME DISTRICT IN THE CITY OF LEEDS, ALABAMA**

**WHEREAS**, the Planning Commission of the City of Leeds, Alabama has received a request to amend the City's Official Zoning Map, and has made, a report of their recommendations concerning the rezoning of the following parcel of property from R-2, Single Family District to R-5, Garden Home District; and

**WHEREAS**, the City of Leeds City Council held a formal public hearing for the purpose of considering an ordinance to amend the zoning map of the City in accordance with said zoning request on January 6, 2020; and

<b>CASE #:</b>	<b>Z-2019-008</b>
<b>APPLICANT NAME:</b>	<b>MICHAEL MYRICK &amp; JANIE MYRICK</b>
<b>PROPERTY OWNER:</b>	<b>MYRICK JACK A JR &amp; JANIE P; MYRICK MICHAEL G ETAL</b>
<b>TAX PARCEL ID:</b>	<b>2605161001037000; 2605161001042000; 2605161001040000; 2500164001001.000</b>
<b>SITE ADDRESS:</b>	<b>1730 Jones St., Leeds, AL 35094 – Site Only Jefferson CO &amp; St. Clair Co</b>
<b>CURRENT ZONING:</b>	<b>R-2, SINGLE FAMILY RESIDENTIAL DISTRICT</b>
<b>PROPOSED ZONING:</b>	<b>R-5, GARDEN HOME DISTRICT</b>

**WHEREAS**, Resolution and Proposed Ordinance were published in accordance with State Law and City Ordinance by posting in four (4) conspicuous places.

**NOW, THEREFORE BE IT ORDAINED BY THE CITY COUNCIL OF THE CITY OF LEEDS, ALABAMA, AS FOLLOWS:**

The City's Official Zoning Map shall be amended to rezone the above listed parcel of property from R-2, Single Family District to R-5, Garden Home District according to the City's current zoning regulations.

**READ, APPROVED AND ADOPTED** at a regular meeting of the City Council of the City of Leeds, Alabama on this this the day of January 6, 2020.

**BE IT FURTHER ORDAINED** that the Mayor and City staff shall have the full authority to do those things, perform those functions, and to sign necessary documentation in order to carry out the actions so authorized herein.

**BE IT FURTHER ORDAINED**, that the provisions of this Ordinance are severable if any part of this Ordinance is determined by a court of law to be invalid, unenforceable or unconstitutional, such determination shall not affect any other part of this Ordinance.

AYES:

NAYS:

ABSENT FROM VOTI NG:

ABSTAIN:

CITY OF LEEDS, ALABAMA

\_\_\_\_\_  
David Miller, MAYOR

\_\_\_\_\_  
DATE

ATTEST:

\_\_\_\_\_  
Toushi Arbitelle, City Clerk

I, Toushi Arbitelle, City Clerk of the City of Leeds, hereby certify that the above Ordinance was duly adopted by the City Council of the City of Leeds at a regular meeting held on the 6<sup>th</sup> day of January 2020.

\_\_\_\_\_  
Toushi Arbitelle, City Clerk

Z-2019-008

1730 JONES ST.

260516001037000;2605161001042000;2605161001040000;  
250016400100100

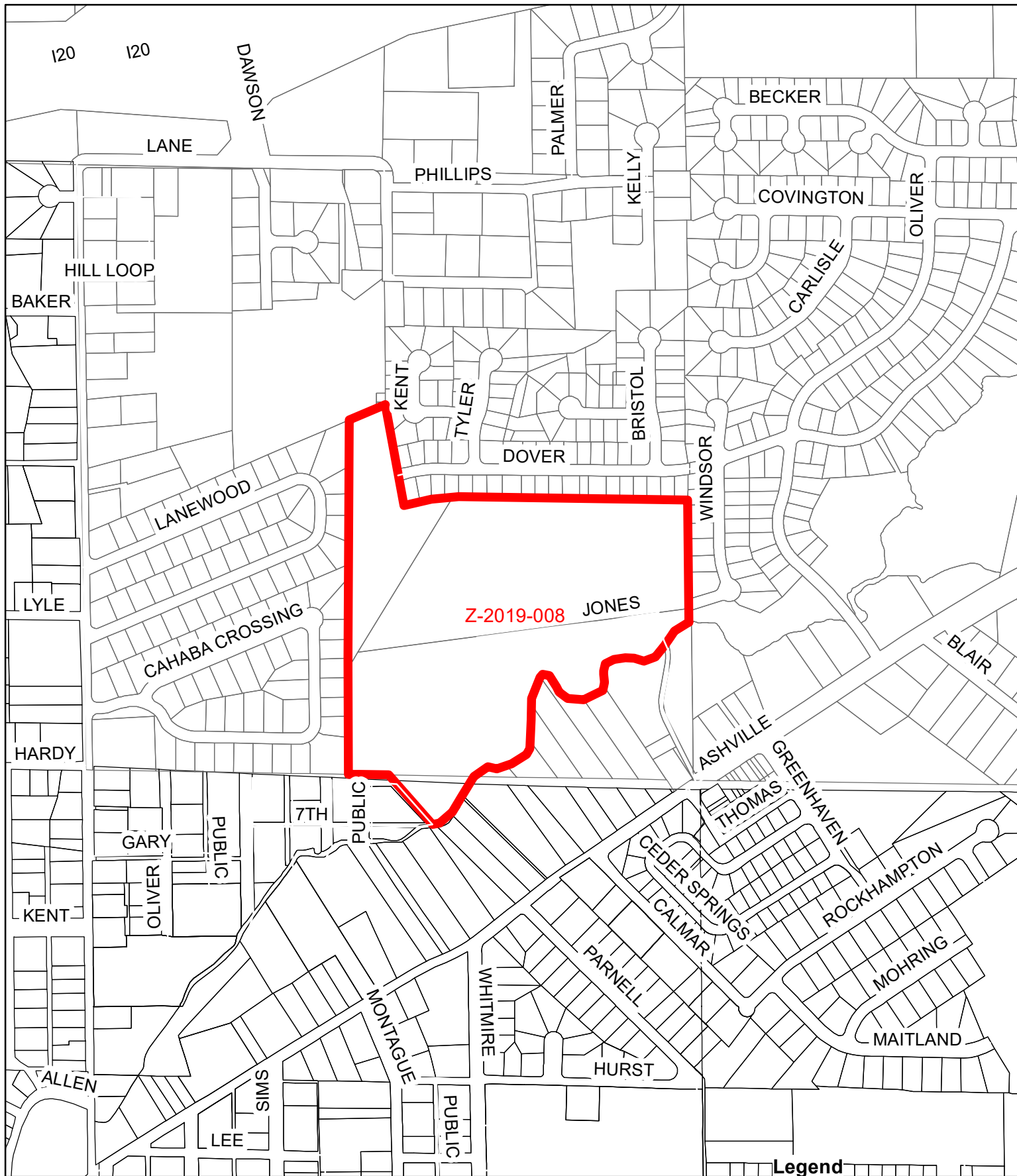

This instrument was prepared by

(VOL 93 PAGE 625)

REAL 452 PAGE 3

(Name) Willard O. Jackson, Attorney

(Address) Leeds, Alabama

Form 1-1-1 Rev. 1-66  
WARRANTY DEED, JOINTLY FOR LIFE WITH REMAINDER TO SURVIVOR—LAWYERS TITLE INSURANCE CORPORATION, Birmingham, Alabama

STATE OF ALABAMA }  
JEFFERSON COUNTY } KNOW ALL MEN BY THESE PRESENTS,

That in consideration of Ten and NO/100-----(\$10.00)-----DOLLARS

and other good and valuable consideration to the undersigned grantor or grantors in hand paid by the GRANTEEES herein, the receipt whereof is acknowledged, we, Edwin G. Goss and wife, Jo Ann M. Goss (herein referred to as grantors) do grant, bargain, sell and convey unto John A. Myrick, Jr. and wife, Janie Patton Myrick

(herein referred to as GRANTEEES) for and during their joint lives and upon the death of either of them, then to the survivor of them in fee simple, together with every contingent remainder and right of reversion, the following described real estate situated in Jefferson and St. Clair County, Alabama to-wit:

Parcel #26-05-16-1-001-042.000  
From the SW corner SE 1/4 of NE 1/4 of Sec. 16, T 17 S, R 1 E, the point of beginning of the within described property, run South 88° 48' W, 150.00 feet; thence North 3° 26' W, 554.98 feet; thence North 80° 42' E, 551.96 feet; thence North 80° 27' E, 956.42 feet to point 20 feet west of east line of said SE 1/4 of NE 1/4; thence South 2° 45' E, 71.00 feet to the center of Cahaba Creek; thence follow the center of said creek southwesterly to where the said creek intersects the south line of the SE 1/4 of the NE 1/4 of Sec. 16, T 17, R 1; thence west along the south line of said SE 1/4 of the NE 1/4 to the point of beginning, being a part of the SE 1/4 of NE 1/4 and SW 1/4 of NE 1/4 of Sec. 16, T 17 S, R 1 E, St. Clair County, Alabama.

A L S O

Parcel #25-00-16-4-001-001.000  
Part of the NE 1/4 of the SE 1/4 of Sec. 16, T 17 S, R 1 E, situated in Jefferson County, Alabama, more particularly described as follows:

Begin at the NW corner of said 1/4-1/4 section, run thence eastwardly along the north line of said 1/4-1/4 section to the center line of Cahaba Creek; run thence southwestwardly along the center line of said Cahaba Creek to a point which lies south 47° 56' East, 310.86 feet from the NW corner of said 1/4-1/4 section; run thence North 47° 56' West for a distance of 310.86 feet to the point of beginning.

TO HAVE AND TO HOLD to the said GRANTEEES for and during their joint lives and upon the death of either of them, then to the survivor of them in fee simple, and to the heirs and assigns of such survivor forever, together with every contingent remainder and right of reversion.

And I (we) do for myself (ourselves) and for my (our) heirs, executors, and administrators covenant with the said GRANTEEES, their heirs and assigns, that I am (we are) lawfully seized in fee simple of said premises; that they are free from all encumbrances, unless otherwise noted above; that I (we) have a good right to sell and convey the same as aforesaid; that I (we) will and my (our) heirs, executors and administrators shall warrant and defend the same to the said GRANTEEES, their heirs and assigns forever, against the lawful claims of all persons.

IN WITNESS WHEREOF, WE have hereunto set OUR hand(s) and seal(s), this 29th day of July, 1968

WITNESS:  
Douglas L. Liggins (Seal)  
Charles Murray (Seal)

Edwin G. Goss (Seal)

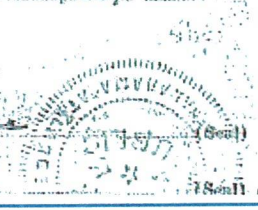

(N) Willard O. Jackson, Attorney

(A) 149 Leeds, Alabama

Form 1-1-5 Rev. 1-66  
WARRANTY DEED, JOINTLY FOR LIFE WITH REMAINDER TO SURVIVOR—LAWYERS TITLE INSURANCE CORPORATION, Birmingham, Alabama

STATE OF ALABAMA }  
JEFFERSON COUNTY } KNOW ALL MEN BY THESE PRESENTS,

That in consideration of Ten and NO/100-----(\$10.00)-----DOLLARS

and other good and valuable consideration to the undersigned grantor or grantors in hand paid by the GRANTEES herein, the receipt whereof is acknowledged, we, Edwin G. Goss and wife, Jo Ann M. Goss (herein referred to as grantors) do grant, bargain, sell and convey unto John A. Myrick, Jr. and wife, Janie Patton Myrick

(herein referred to as GRANTEES) for and during their joint lives and upon the death of either of them, then to the survivor of them in fee simple, together with every contingent remainder and right of reversion, the following described real estate situated in Jefferson and St. Clair County, Alabama to-wit:

From the SW corner SE 1/4 of NE 1/4 of Sec. 16, T 17 S, R 1 E, the point of beginning of the within described property, run South 88° 48' W, 150.00 feet; thence North 3° 26' W, 554.98 feet; thence North 80° 42' E, 551.96 feet; thence North 80° 27' E, 956.42 feet to point 20 feet west of east line of said SE 1/4 of NE 1/4; thence South 2° 45' E, 71.00 feet to the center of Cahaba Creek; thence follow the center of said creek southwesterly to where the said creek intersects the south line of the SE 1/4 of the NE 1/4 of Sec. 16, T 17, R 1; thence west along the south line of said SE 1/4 of the NE 1/4 to the point of beginning, being a part of the SE 1/4 of NE 1/4 and SW 1/4 of NE 1/4 of Sec. 16, T 17 S, R 1 E, St. Clair County, Alabama.

A L S O

Part of the NE 1/4 of the SE 1/4 of Sec. 16, T 17 S, R 1 E, situated in Jefferson County, Alabama, more particularly described as follows:

Begin at the NW corner of said 1/4-1/4 section, run thence eastwardly along the north line of said 1/4-1/4 section to the center line of Cahaba Creek; run thence southwestwardly along the center line of said Cahaba Creek to a point which lies south 47° 56' East, 310.86 feet from the NW corner of said 1/4-1/4 section; run thence North 47° 56' West for a distance of 310.86 feet to the point of beginning.

TO HAVE AND TO HOLD to the said GRANTEES for and during their joint lives and upon the death of either of them, then to the survivor of them in fee simple, and to the heirs and assigns of such survivor forever, together with every contingent remainder and right of reversion.

And I (we) do for myself (ourselves) and for my (our) heirs, executors, and administrators covenant with the said GRANTEES, their heirs and assigns, that I am (we are) lawfully seized in fee simple of said premises; that they are free from all encumbrances, unless otherwise noted above; that I (we) have a good right to sell and convey the same as aforesaid; that I (we) will and my (our) heirs, executors and administrators shall warrant and defend the same to the said GRANTEES, their heirs and assigns forever, against the lawful claims of all persons.

IN WITNESS WHEREOF, we have hereunto set our hand(s) and seal(s), this 29th day of July, 1968.

WITNESS:  
Dorcas L. Figgles (Seal)  
Charles Murray (Seal)  
J. Bernard Owen, Jr. (Seal)

Edwin G. Goss (Seal)  
Jo Ann M. Goss (Seal)

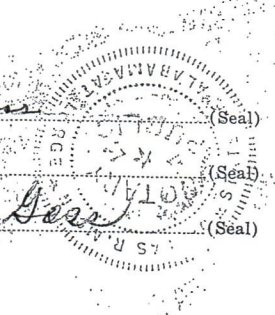

STATE OF ALABAMA }  
MADISON COUNTY }

General Acknowledgment

I, the undersigned authority, a Notary Public in and for said County, in said State, hereby certify that Edwin G. Goss and wife, Jo Ann M. Goss whose name s. are signed to the foregoing conveyance, and who are known to me, acknowledged before me on this day, that, being informed of the contents of the conveyance they executed the same voluntarily on the day the same bears date.

Given under my hand and official seal this 29th day of July A. D., 1968  
My Commission Expires Nov. 30, 1970  
Dallas K. Moor Notary Public

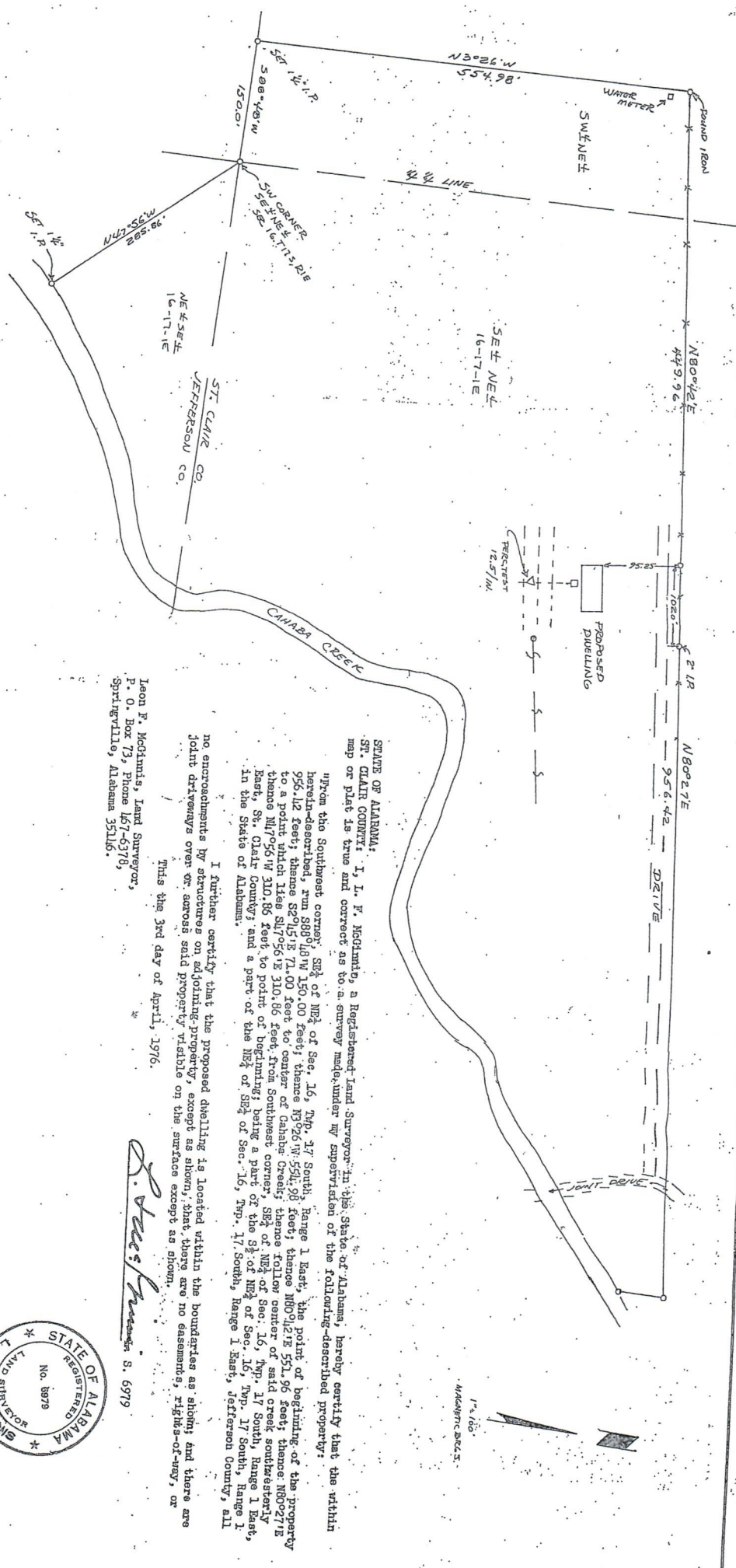

STATE OF ALABAMA:  
 ST. CLAIR COUNTY: I, I. F. McGinnis, a Registered Land Surveyor in the State of Alabama, hereby certify that the within map or plat is true and correct as to a survey made under my supervision of the following described property:

Upon the Southwest corner, S87° of NE 1/4 of Sec. 16, Twp. 17 South, Range 1 East, the point of beginning of the property herein-described, run S89°18'W 150.00 feet; thence N9°26'W 551.98 feet; thence N80°42'W 511.96 feet; thence N80°27'E 956.42 feet; thence S2°45'E 71.00 feet to center of Canaba Creek; thence follow center of said creek southeasterly thence N47°05'W 310.86 feet, from Southwest corner, S87° of NE 1/4 of Sec. 16, Twp. 17 South, Range 1 East, St. Clair County; and a part of the 1/4 of NE 1/4 of Sec. 16, Twp. 17 South, Range 1 East, Jefferson County, all in the State of Alabama.

I further certify that the proposed dwelling is located within the boundaries as shown; and there are no encroachments by structures on adjoining property, except as shown; that there are no easements, rights-of-way, or joint driveways over or across said property visible on the survey except as shown.

This the 3rd day of April, 1976.

Leon F. McGinnis, Land Surveyor,  
 P. O. Box 73, Phone 457-6376,  
 Springville, Alabama 35116.

*I. F. McGinnis*  
 Registered Land Surveyor S. 6979

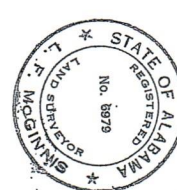

## LEGAL DESCRIPTION

Parcels of land situated in and being part of the SE 1/4 of the NE 1/4 and a part of the SW 1/4 of the NE 1/4 of Section 16, Township 17 South, Range 1 East, St Clair County, Alabama, Pell City Division and being more particularly described as follows:

## TRACT 1: Parcel #26-05-16-1-001-029.000

Commence at a 2" crimped pipe locally excepted as the NE corner of Section 16, Township 17 South, Range 1 East and run South 02° 44' 02" East a distance of 1415.44 feet; thence South 88° 38' 20" West a distance of 448.83 feet; thence South 88° 39' 46" West a distance of 605.32 feet to the Point of Beginning of the following tract of land; thence South 88° 42' 47" West a distance of 36.99 feet thence South 76° 06' 02" West a distance of 177.59 feet; thence North 13° 53' 58" West a distance of 451.05 feet; thence South 64° 23' 13" West a distance of 153.13 feet; thence South 02° 34' 24" East a distance of 1006.87 feet; thence North 79° 44' 13" East a distance of 12.00 feet; thence North 30° 33' 13" East a distance of 784.49 feet to the point of beginning.

## TRACT 2: Parcel #26-05-16-1-001-037.000

Commence at a 2" crimped pipe locally excepted as the NE corner of Section 16, Township 17 South, Range 1 East and run South 02° 44' 02" East a distance of 1415.44 feet to the Point of Beginning of the following tract of land; thence South 88° 38' 20" West a distance of 448.83 feet; thence South 88° 39' 46" West a distance of 605.32 feet; thence South 30° 33' 13" West a distance of 784.49 feet to a 2 inch open pipe found; thence North 81° 01' 13" East a distance of 339.47 feet; thence North 80° 56' 13" East a distance of 199.58 feet; thence North 80° 45' 13" East a distance of 300.80 feet; thence North 80° 43' 13" East a distance of 226.00 feet; thence North 80° 34' 13" East a distance of 213.31 feet; thence North 80° 58' 13" East a distance of 214.64 feet; thence North 02° 44' 02" West a distance of 463.04 feet to the point of beginning.

LESS AND EXCEPT that parcel acquired by Jones Street, LLC by quitclaim deed from Larry Alan Johnson filed on 3-24-03, in Deed Book 2003, page 2509 in the Probate Office of St. Clair County, Alabama. The grantor therein only had a tax interest as acquired by virtue of prior tax sale and tax deed dated 5-14-84 and attached to and made a part of the instrument referenced hereinabove. Said parcel being more particularly described as follows:

Commence at the NE corner of Section 16; thence run West 20 feet; thence run South 1450 feet to the point of beginning, thence West 110' x 50' X 100' x 50' to the point of beginning.

Said parcel also being referred to as Tax Parcel No. 59-26-05-16-0.001-038.

## TRACT 3:

## Parcel I: Parcel #26-05-16-1-001-040.000

Commence at a 2" crimped pipe locally excepted as the NE corner of Section 16, Township 17 South, Range 1 East and run South 02° 44' 02" East a distance of 1949.17 feet to the Point of Beginning of the following tract of land; thence South 02° 44' 02" East a distance of 682.87 feet; thence South 54° 20' 00" West a distance of 14.65 feet; thence North 35° 40' 00" West a distance of 167.00 feet thence North 54° 20' 00" East a distance of 21.00 feet; thence North 27° 24' 11" West a distance of 62.60 feet thence South 54° 20' 00" West a distance of 130.00 feet; thence North 35° 40' 00" West a distance of 324.04 feet to the centerline of Little Cahaba Creek; thence along the centerline of said creek the

following: North 04° 02' 22" East a distance of 92.52 feet; thence North 58° 25' 10" East a distance of 42.15 feet; thence North 80° 15' 27" East a distance of 59.79 feet; thence South 86° 23' 24" East a distance of 87.64 feet; thence North 62° 43' 30" East a distance of 32.11 feet; thence North 38° 04' 35" East a distance of 80.62 feet; thence North 44° 20' 46" East a distance of 117.11 feet; thence North 61° 08' 20" East a distance of 38.92 feet to the point of beginning.

LESS AND EXCEPT existing right of way of Jones Road (20' ROW).

PARCEL II: Parcel#26-05-16-1-001-037.000

That parcel acquired by Jones Street, LLC by quit claim deed from Larry Alan Johnson filed on 3-24-03, in Deed Book 2003, page 2509 in the Probate Office of St. Clair County, Alabama. The grantor therein only had a tax interest as acquired by virtue of prior tax sale and tax deed dated 5-14-84 and attached to and made a part of the instrument referenced hereinabove. Said parcel being more particularly described as follows:

Commence at the NE corner of Section 16, Township 17 South, Range 1 East, St. Clair County, Alabama, thence run West 20 feet thence run South 1450 feet to the point of beginning, thence West 110' x 50' x 100' X 50' to the point of beginning.

Said parcel also being referred to as Tax Parcel No. 59-26-05-16-0.001-038.



131042-42

671

2013 3039  
Recorded in the Above  
DEED Book & Page  
03-26-2013 08:52:03 AM  
Mike Bowling - Judge of Probate  
St. Clair County, Alabama

**AFTER RECORDING,  
RETURN TO:**

John A. Myrick  
1730 Jones St  
Leeds, AL 35094

[space above reserved for recorder's use only]

**THIS DOCUMENT  
PREPARED BY:**

Hunton & Williams LLP  
1445 Ross Avenue, Suite 3700  
Dallas, Texas 75202  
Attn: Adam B. Fritcher

**SEND TAX NOTICE TO:**

John A. Myrick  
1730 Jones St  
Leeds, AL 35094

who makes no representation as to  
status of title or to matters which  
would be disclosed by a current  
survey

**SPECIAL WARRANTY DEED**

STATE OF ALABAMA           §  
  §  
COUNTY OF ST. CLAIR     §

KNOW ALL MEN BY THESE PRESENTS:

**KNOW ALL MEN BY THESE PRESENTS**, that for and in consideration of the sum of TEN AND NO/100 Dollars (\$10.00) and other good and valuable consideration to the undersigned Grantor paid by the Grantee herein, the receipt whereof is acknowledged, the said **LPP MORTGAGE LTD.**, a Texas limited partnership, whose mailing address is: c/o CLMG Corp., 7195 Dallas Parkway, Plano, Texas 75024 ("**Grantor**"), DOES GRANT, BARGAIN, SELL AND CONVEY unto **MICHAEL G. MYRICK, JOHN A. MYRICK and JANIE P. MYRICK**, as joint tenants with rights of survivorship (collectively, the "**Grantee**"), having an address of 539 Woodruff Parkway, Leeds, Alabama 35094, the real property situated in the County of St. Clair, State of Alabama, and more particularly described on Exhibit A attached hereto and made a part hereof for all purposes, together with all of Grantor's right, title and interest, if any, in and to all easements benefiting such real property (collectively, the "**Property**").

This Special Warranty Deed is made and accepted expressly subject to any and all matters of record, and any easements, exceptions, restrictions, rights of redemption and other encumbrances and any

and all matters that would be shown by a visual inspection and/or accurate survey of the Property, including, without limitation, the matters set forth in Exhibit B attached hereto and made a part hereof for all purposes (the "**Permitted Exceptions**").

TO HAVE AND TO HOLD the Property, subject to the Permitted Exceptions, unto Grantee, its successors and assigns forever; and Grantor does hereby bind itself, its successors and assigns to WARRANT AND FOREVER DEFEND all and singular the Property unto Grantee and its successors and assigns, against any person whomsoever lawfully claiming or to claim the same or any part thereof by, through or under Grantor, but not otherwise, subject to the Permitted Exceptions.

[SIGNATURE PAGE FOLLOWS]

IN WITNESS WHEREOF, Grantor has executed this Special Warranty Deed to be effective as of the 21<sup>st</sup> day of March, 2013.

**GRANTOR:**

**LPP MORTGAGE LTD.,**  
a Texas limited partnership

By: Property Acceptance Corp.,  
a Texas corporation,  
its general partner

By: *Michael D. Wyant*  
Name: **Michael D. Wyant**  
Its: **Its Authorized Signatory**

STATE OF TEXAS

§  
§  
§

COUNTY OF COLLIN

I, the undersigned authority, a Notary Public, in and for said county in said state, hereby certify that *Michael D. Wyant*, the Authorized Signatory of Property Acceptance Corp., a Texas corporation, the general partner of LPP MORTGAGE LTD., a Texas limited partnership, and whose name is signed to the foregoing instrument, and who is known to me, acknowledged before me on this day that, being informed of the contents of said instrument, he, as such Authorized Signatory and with full authority, executed the same voluntarily for and as the act of said corporation and said limited partnership.

Given under my hand and official seal this 18 day of March, 2013.

(Seal)



*Cindy Lewis*  
Notary Public for the State of Texas  
(signature of Notary Public)

My Commission Expires: *Sept. 22, 2013*

**Item Attachment Documents:**

21. Resolution 19-001868 Consider Determination of Certain Conditions to be an Annoyance and Public Nuisance in Violation of Chapter 32 of the Code of Ordinances at 1042 Brian Dr

**CITY OF LEEDS  
RESOLUTION 19-001868**

**RESOLUTION IN DETERMINATION OF CERTAIN CONDITIONS TO BE AN ANNOYANCE AND PUBLIC NUISANCE IN VIOLATION OF CHAPTER 32 OF THE CODE OF ORDINANCES, FOR THE CITY OF LEEDS, AL.**

**WHEREAS**, in accordance with, without limitation, Code of Ordinances for the city of Leeds, Alabama Chapter 32, §11-47-117, and 11-67-60 to 11-67-67 Code of Alabama 1975 (cumulatively referred to as the "Law"), the City Council of the City of Leeds has the authority to determine that certain conditions upon certain properties in the city of Leeds are offensive, produce an annoyance, constitute a threat to the general public health, safety and welfare of the City of Leeds, Alabama and are in fact a public nuisance; and

**WHEREAS**, employees or agents of the City of Leeds have identified certain conditions to be a nuisance in violation of the law as existing on the certain property at 1042 BRIAN DR LEEDS, AL 35094, Parcel ID: 2500202001027000 which is identified in Exhibit A attached hereto and incorporated herein (the "Property"); and

**WHEREAS**, in accordance with the Law, the City Council of the City of Leeds, after considering the report and the associated notices as presented by staff, may find that the subject conditions identified by the supporting information and documentation related to the subject property(ies) are a public nuisance and order the immediate abatement of such conditions; and

**WHEREAS**, the City Council of the City of Leeds may hold a public hearing if requested by the property owner to have the opportunity of being heard and to discuss the conditions as presented; and

**WHEREAS**, in accordance with the Law, the City of Leeds is to keep an account of the cost of abating or removing the nuisance on any such property when the owner fails to comply with the provided notices; and

**WHEREAS**, in accordance with the Law, the City Council of the City of Leeds desires to make a determination as to whether or not a public nuisance actually exists at the subject property(ies), based on the information as presented, and potentially order the abatement of any such nuisance(s).

**NOW THEREFORE, BE IT RESOLVED**, by the City Council of the City of Leeds follows:

1. All of the Recitals above are true and correct and are hereby incorporated herein as if fully set forth
2. The conditions identified by the Notice(s) of the Public Nuisance, in relation to the Property(ies) identified on the report as Attached hereto as Exhibit A including the requisite notices and supporting information as provided to the Property owner and posted at the Property, and all hereby declared to be a public nuisance in the City of Leeds.
3. The identified public nuisance(s) is related to the subject property(ies) shall be abated and/or removed by the City, if necessary, with costs assessed to the Subject Property.
4. City staff is to create a report of the related costs for abating or removing any remaining nuisance(s) from the Property and to provide such report back to the City Council for approval of the costs related to the same.
5. The provisions of the Resolution are severable. If any part of the Resolution is determined to be invalid, unenforceable or unconstitutional, such determination shall not affect any other part of this Resolution.
6. The City Budget is amended to fund the deceleration of public Nuisance abatements.

**ADOPTED and APPROVED** this the 01/06/2020  
CITY OF LEEDS, ALABAMA

\_\_\_\_\_  
DAVID MILLER, MAYOR

\_\_\_\_\_  
DATE

ATTEST:

AYES \_\_\_\_\_

NAYS \_\_\_\_\_

ABSENT FROM VOTING \_\_\_\_\_

ABSTAIN \_\_\_\_\_

\_\_\_\_\_  
Toushi Arbitelle,  
CITY CLERK

I, Toushi Arbitelle, City Clerk of the City of Leeds, hereby certify that the above Resolution was duly adopted by the City Council of the City of Leeds at a regular meeting held on 01/06/2020.

\_\_\_\_\_  
Toushi Arbitelle, City Clerk

# City of Leeds, Alabama

Department of Development Services  
1404 9th St. Leeds, AL 35094  
205-699-2585 development@leedsalabama.gov

TRUITT JONATHAN E  
1042 BRIAN DR  
LEEDS, AL 35094

Reference: 19-001868  
Parcel ID: 2500202001027000

## **NOTICE AND ORDER TO ABATE**

**NOTICE IS HEREBY GIVEN THAT** TRUITT JONATHAN E is in violation of Chapter 32 of the City of Leeds, Municipal Code. The violation has been investigated, declared a public nuisance by the City Enforcement Officer and must be abated immediately.

The public nuisance is on property located at: 1042 BRIAN DR LEEDS, AL 35094

**YOU ARE HEREBY ORDERED TO ABATE SAID PUBLIC NUISANCE within ten (10) days** consecutive calendar days from the issuance of this Order. The issuance date is specified below. You may abate the nuisance by REMOVE ITEMS IN VIOLATION OF ORD. 2016-02-04

Section: Sec 32-44  
Description: Illegal Deposits  
Corrective Action: Cease Activity/Remove Offending Material 72 Hrs  
Comments:

Section: Sec 32-76-c  
Description: Inoperable/Unlicensed Vehicle  
Corrective Action: Remove Offending Vehicles 10 Days  
Comments:

If you fail to abate the public nuisance within ten (10) days, the City may order its abatement by public employees, private contractor, or other means, and the cost of said abatement may be levied and assessed against the property as a special assessment lien or billed directly to the property owner.

This Matter will be heard at a hearing before the City Council on 01/06/2020 at the City Civic Center located at 1000 Park Drive, Leeds, Alabama. The decision of the City Council on this Matter will be final and conclusive.

**YOU HAVE THE RIGHT TO BE HEARD** at the hearing identified above. You have the right to:

1. Be present at the hearing and to present your evidence against this Order in writing prior to the hearing;
2. Provide your written statement against the Order and to specify the reasons not to enforce the Order, containing your name, address and telephone number,
3. Submit your written statement & request to be heard to the following address within at least 24 hours prior to the subject hearing: **1404 9th St, Leeds, Alabama. (205) 699-2585**

In the event that the hearing results in confirmation of a public nuisance, the City will take the necessary steps to abate the nuisance and assess all costs against the subject property. The City also reserves the right to forward the matter to the Municipal Court for further enforcement actions pursuant to Chapter 32 of the City Code.

If you have any questions regarding this matter, you may direct them to the City Enforcement Officer issuing this Notice at the address or telephone number listed above.

Signed: \_\_\_\_\_  
Enforcement Officer

ISSUANCE DATE: December 06, 2019



Document: 4

**Date Taken:**12/06/2019  
**Address:**1042 BRIAN DR

**Taken by:**Brad Watson  
**Case Number:**19-001868



Document: 3

**Date Taken:**12/06/2019  
**Address:**1042 BRIAN DR

**Taken by:**Brad Watson  
**Case Number:**19-001868





Document: 2

**Date Taken:**12/06/2019  
**Address:**1042 BRIAN DR

**Taken by:**Brad Watson  
**Case Number:**19-001868



Document: 1

**Date Taken:**12/06/2019  
**Address:**1042 BRIAN DR

**Taken by:**Brad Watson  
**Case Number:**19-001868



Document: 1

**Date Taken:**12/06/2019  
**Address:**1042 BRIAN DR

**Taken by:**Brad Watson  
**Case Number:**19-001868

**Item Attachment Documents:**

22. Resolution 2020-01-01 Consider Animal Control and Pound Services Contract

# CITY OF LEEDS

## RESOLUTION NO.: 2020-01-01

### A RESOLUTION TO CONTRACT WITH THE GREATER BIRMINGHAM HUMANE SOCIETY FOR ANIMAL CONTROL AND POUND SERVICES

**WHEREAS**, on January 2019, the Jefferson County Commission issued an Invitation to Bid No. 4-16 (“ITB”) on behalf of the Purchasing Association of Central Alabama (“PACA”) and its Members, whereby it would accept sealed bids for Animal Control and Pound Services pursuant to the ITB; and

**WHEREAS**, on January 2019, Jefferson County awarded the bid pursuant to the ITB No. 4-16 as amended, to The Greater Birmingham Humane Society, Inc. (“GBHS”); and

**WHEREAS**, the Services, defined herein, to be performed under the ITB may be performed by a subcontractor of the GBHS which is The Greater Birmingham Humane Society Animal Care and Control, LLC (“Vendor”); and

**WHEREAS**, the City of Leeds (“City”), as a Member of PACA, is entitled to enter into an Agreement for Animal Control Services as set out in the ITB (the “Services”); and

**WHEREAS**, the ITB includes pound services to be paid on a pro rata basis to Jefferson County (the “Pound Services”) but does not include animal control field services for municipalities with a population over 5,000 pursuant to the Code of Alabama 1975, Section Title 3-7A-7; and

**WHEREAS**, the City desires to retain GBHS to perform Services, excluding where applicable Pound Services; and

**NOW, THEREFORE, BE IT RESOLVED** by the City Council (the “Council”) of the City of Leeds:

**Section 1. Recitals.** The foregoing Recitals are incorporated herein by reference and form an integral part of this Resolution.

**Section 2. Invitation to Bid 4-16.** GBHS has acknowledged that the terms of the ITB are hereby offered to the City and shall be incorporated into the provision of Services provided for in this resolution.

**Section 3. Public Purpose.** The Council does hereby ascertain, determine, declare and find that GBHS provision of the Services and entering into an agreement as provided in Section 5 will serve a public purpose and is necessary and desirable, and in the best interest of the City and the health, safety and welfare of its inhabitants, by allowing for the humane control and care of animals in the City and access to pound facilities. The Council finds that the above-cited items constitute important public benefits to the City and its citizens.

**Section 4. Approval to Perform the Services.** GBHS submitted a “Price Sheet” in response to the ITB, which is attached as Exhibit “A” hereto and incorporated by reference as if set out fully herein, (the “Price Sheet”) and the Council hereby approves and authorizes GBHS to perform the Services as set out in the ITB in the City and the City shall pay GBHS the cost not to

exceed the amounts set forth in the Price Sheet, excluding where applicable Pound Services paid pro-rata to Jefferson County, as provided in the ITB.

**Section 5. Agreement for Services.** The Price Sheet sets forth the prices for the Services to be performed by GBHS in the City. The Mayor of the City is hereby authorized and directed to negotiate with GBHS on behalf of the City and execute and deliver on behalf of the City an agreement in substantially the form set forth in Exhibit “B”, with such changes or additions to such agreement as the Mayor of the City shall approve, which approval shall be conclusively evidenced by his or her execution of the agreement and attestation by the City Clerk.

**Section 6. Approved Subcontractor.** Vendor was expressly incorporated into the response to the ITB to perform services for GBHS as a subcontractor. Vendor, as a subcontractor, is hereby approved to perform all or a portion of the Services for the City.

**Section 7. Other Necessary Action.** The officers and staff of the Council and Mayor are hereby authorized to take such other action as may be necessary or desirable to carry out the provisions of this resolution.

**Section 8. Relationship.** GBHS is an independent contractor of the City. This resolution does not create any partnership, joint venture or principal-agent relationship between the City and GBHS. Further, the City retains no control or authority with respect to its means and methods in which GBHS (or any of its employees, subcontractors, or representatives) performs the Services.

**Section 9. Provisions of Resolution a Contract.** The terms, provisions and conditions set forth in this resolution constitute a contract between the City and GBHS conferring all necessary legal authority for GBHS to perform the Services in the City and shall remain in effect until an agreement is executed in accordance with Section 5 of this resolution or one year, whichever is earlier.

**Section 10. Severability.** If any provision in this resolution shall be invalid, illegal or enforceable, the validity, legality and enforceability of the remaining provisions shall not in any way be affected or impaired thereby.

**ADOPTED AND APPROVED** at a regular meeting of the City Council of the City of Leeds, Alabama on this the 6<sup>th</sup> day of January 2020

**CITY OF LEEDS, ALABAMA**

\_\_\_\_\_  
**David Miller, Mayor**

\_\_\_\_\_  
Date

**ATTEST:**

**AYES:** \_\_\_\_\_

**NAYS:** \_\_\_\_\_

**ABSENT:** \_\_\_\_\_

\_\_\_\_\_  
**Toushi Arbitelle, City Clerk**

**ABSTAIN:** \_\_\_\_\_

In my capacity as the City Clerk of the City of Leeds, hereby certify that the above Resolution was duly adopted by the City Council of the City of Leeds at a regular meeting held on the 6th day of January 2020

\_\_\_\_\_  
City Clerk

**EXHIBIT A**

**Animal Control and Pound Services**

Price Sheet

**1. Animal Control Field Services**

- A. Full time animal control vehicle (based on 40 hour work week) \$ 7,083.00 per vehicle/per month
- B. Animal control vehicle \$ 327.00 per vehicle/per day
- C. Animal control vehicle \$ 41.00 per vehicle/per hour
- D. After hours and weekend \$ 61.50 per vehicle/per hour (1/2 hour minimum)

**2. Animal Boarding**

- A. Weaned Animal \$ 42.00 per animal/per total stay
- B. Un-Weaned Animal \$ 0.00 per animal/per total stay
- C. Quarantined Animal \$ 9.00 per animal/per day
- D. Livestock \$ 6.00 per animal/per day

**3. Pricing for Animals Seized Under the Authority of the Pet Protection Act**

- A. Boarding \$ 6.00 per day
- B. Medical Care \$ 12.00 total cost
- C. Euthanasia \$ 10.00 per animal

**4. Adoptions with Alteration**

- A. Dog \$ 60.00 per animal
- B. Cat \$ 50.00 per animal

**5. Rabies Test Preparation**

- A. Office Bring In \$ 7.00 per animal
- B. Field Pick Up \$ 11.00 per animal

**6. Out of County Surrenders**

- A. Owned \$ 15.00 per animal
- B. Stray \$ 20.00 per animal

**7. Euthanasia Service Only**

- A. Euthanasia \$ 10.00 per animal

**8. Law Enforcement Requested Service Not Mandated by Law or Local Ordinance**

- A. Field Services: See Category 1 Above
- B. Boarding \$ 26.00 per animal/per day
- C. Euthanasia: See 3C Above

**9. Animal Rescue Services**

- A. Rabies Vaccination \$ 6.00 per animal
- B. Preventative Vaccines \$ 15.00 per animal

Prices Quoted Per Amendment 2 of ITB 4-16



**EXHIBIT B**

[FORM OF]

# Animal Control Services Fee for Service Contract

**THIS AGREEMENT** entered into this 6<sup>th</sup> day of January 2020, by and between the City of Leeds, (hereinafter “City”) and The Greater Birmingham Humane Society, Inc. (hereinafter “Vendor”).

**WHEREAS**, on January 2019, the Jefferson County Commission issued an Invitation to Bid No. 4-16 (“ITB”) on behalf of the Purchasing Association of Central Alabama (“PACA”) and its Members, whereby it would accept sealed bids for Animal Control and Pound Services pursuant to the ITB; and

**WHEREAS**, on January, 2019 Jefferson County awarded the bid pursuant to the ITB No. 4-16, as amended, to The Greater Birmingham Humane Society, Inc.; and

**WHEREAS**, the Services, defined herein, to be performed under the ITB may be performed by a sub-Contractor of the GBHS which is The Greater Birmingham Humane Society Animal Care and Control, LLC; and

**WHEREAS**, the City, as a Member of PACA, is entitled to enter into an Agreement with for Animal Control Services as set out in the ITB (the “Services”); and

**WHEREAS**, the ITB includes pound services to be paid on a pro-rata basis to Jefferson County (the “Pound Services”) but does not include animal control field services for municipalities with a population over 5,000 pursuant to the Code of Alabama 1975, Section Title 3-7A-7; and

**WHEREAS**, the City desires to Contract for Services, excluding where applicable Pound Services, on a fee for service basis; and

**WHEREAS**, the Vendor desires to furnish said services to the City;

**NOW THEREFORE**, the parties hereto mutually agree as follows:

1. **ENGAGEMENT OF VENDOR:** The City hereto agrees to engage the Vendor and the Vendor hereby agrees to perform the services hereinafter set forth.

2. **SCOPE OF SERVICE:** This contract results from the ITB. The terms of which are included herein by reference. The City desires to enter into a contract with the Vendor to provide the Services, excluding where applicable Pound Services, on a fee for services basis as described in the ITB and attached Price Sheet.

3. **TERMS OF AGREEMENT AND AUTHORIZATION TO PERFORM WORK:** This contract is for the earlier of one (1) year or until \_\_\_\_\_, effective upon

signatures of the below designated officials, and shall continue in effect unless termination notice is given as herein provided.

a. This term is subject to a sixty (60) day cancellation by either party for any reason, so long as proper notice is sent to the addresses as provided under Number 13 “Notices” of this Agreement.

b. Vendor shall provide at least a thirty (30) day notification of change to any hourly rate or boarding fee. Should a rate change occur and municipal funding is lacking, the City shall be permitted to terminate all services on the thirtieth day following the notification of a rate change.

**4. COMPENSATION:** The Vendor shall be compensated for services rendered, excluding where applicable Pound Services paid pro-rata to Jefferson County, as shown on the Price Sheet attached as Exhibit “A”. With respect to Animal Control Field Services, Vendor will provide those services at \$41 per hour for 4 hours per week. Vendor will invoice the City for the Services including basic monthly charge, veterinary fees and animal boarding fees no later than ten (10) days after the beginning of each month for the preceding month. City shall reimburse Vendor for invoiced services in a timely manner, not to exceed fourteen (14) days following receipt.

**5. ASSIGNMENT:** No portion of the proposal or resulting project contract may be sold, assigned, transferred or conveyed to a third party without the express written consent of the City. The City hereby approves all sub-Contractors included in the Vendor’s response to the ITB. Should the City authorize Vendor to subcontract (assign) any portion of this contract, Vendor will maintain the ultimate legal responsibility for all services according to contract specifications. In the event of a subcontract, Vendor must maintain a continuous effective business relationship with the sub-Contractor(s) including, but not limited to, regular payment of all monies owed to any sub-Contractor. Failure to comply with these requirements, in whole or part, will result in termination of the contract and/or legal ramifications, due to nonperformance.

**6. GOVERNING LAW/DISPUTE RESOLUTION:** The parties agree that this contract is made and entered into in Jefferson County, Alabama and that all services, materials and equipment to be rendered pursuant to said Agreement are to be delivered to the City in Jefferson County, Alabama. The interpretation and enforcement of this Agreement will be governed by the laws of the State of Alabama. The parties agree that jurisdiction and venue over all disputes arising under this Agreement shall be the Circuit Court of Jefferson County, Alabama.

**7. STATEMENT OF CONFIDENTIALITY:** Vendor agrees that any information accessed or gained in performance of those duties will be maintained in absolute confidence and will not be released, discussed, or made known to any party or parties for any reason whatsoever, except as required in the conduct of duties required, or where disclosure is required by law or mandated by a court of law.

**8. INDEPENDENT CONTRACTOR:** The Vendor acknowledges and understands that the performance of this contract is as an Independent Contractor and as such, the Vendor is

obligated for Workmen’s Compensation, FICA taxes, Occupational Taxes, all applicable federal, state and local taxes, etc. and that the City will not be obligated for same under this contract.

**9. NON-DISCRIMINATION POLICY:** The Vendor will not discriminate against any employee or applicant for employment because of race, color, religion, sex, national origin, age, disability or veteran status, pursuant to the provisions of Title VII of the Civil Rights Act of 1964, 42 U.S.C. 1981, 1983, 1986 and all amendments thereto relevant to discriminatory employment practices. The Vendor will ensure that qualified applicants are employed, and that employees are treated during employment, without regard to their race, color, religion, sex, national origin, age, disability or veteran status. Such action shall include, but not be limited to, the following: employment, promotion, demotion, or transfer; recruitment or recruitment advertising; layoff or termination; rates of pay or other forms of compensation; and, selection for training, including apprenticeship. In the event of Vendor’s non-compliance with the equal opportunity clause of this contract, this contract may be cancelled, terminated, or suspended in whole or in part and the Vendor may be declared ineligible for further City contracts. This paragraph must also be included in any subcontract or purchase order by Vendor on behalf of the City. Vendor agrees to furnish to the City, upon request, reports, notices, policies and/or information certifying compliance with this policy.

**10. MISCELLANEOUS REQUIREMENTS:** Upon execution of this contract, the Vendor shall furnish the City with information required for Form 1099 reporting and other pertinent data required by law.

**11. TERMINATION OF CONTRACT:** This contract may be terminated by the City with a sixty (60) day written notice to the other party regardless of reason. Any violation of this agreement shall constitute a breach and default of this agreement. Upon such breach, the City shall have the right to immediately terminate the contract and withhold further payments. Such termination shall not relieve the Vendor of any liability to the City for damages sustained by virtue of a breach by the Vendor.

**12. LIABILITY:** The Vendor will indemnify and hold harmless the City, its elected officials and its employees from claims, suit, action, damage and cost of every name and description resulting from the performance of the Vendor, its agents, sub-Contractors or employees under this contract. The City agrees, to the extent allowed by law, to indemnify and save harmless the Vendor, its corporate officers and its employees from claims, suit, action, damage and cost of every name and description resulting from the performance of services unless negligence is found on part of Vendor.

**13. NOTICES:** Unless otherwise provided herein, all notices or other communications required or permitted to be given under this contract shall be in writing and shall be deemed to have been duly given if delivered personally in hand or sent via certified mail, return receipt requested, postage prepaid, and addressed to the appropriate party at the following addresses or to any other person at any other address as may be designated in writing by the parties:

City of Leeds  
City Clerk  
1400 9<sup>th</sup> Street  
Leeds, AL 35094

The Greater Birmingham Humane Society, Inc.  
300 Snow Drive  
Birmingham, AL 35209

**14. AMENDMENT OF AGREEMENT:** This contract contains the entire understanding of the parties, does not change any term or provision of the contract and shall be valid or binding unless so amended by written instrument which has been executed or approved by the City. Any such amendment shall be attached to and made a part of this contract. A written request must be made to the City and an amended agreement will be executed.

**15. INSURANCE:** Vendor will maintain such insurance as required in the ITB and as will protect him and the City from claims under Workmen’s Compensation Acts and from claims for damage and/or personal injury, including death, which may arise from operations under this contract. Insurance will be written by companies authorized to do business in Jefferson County, Alabama. Evidence of insurance will be furnished to the Purchasing Agent upon request.

**16. HOLD HARMLESS AND INDEMNIFICATION:** Contracting party agrees to indemnify, hold harmless and defend the City, its elected officers and employees, and agents (hereinafter referred to in this paragraph collectively as “City”), from and against any and all loss expense or damage, including court cost and attorney’s fees, for liability claimed against or imposed upon the City because of bodily injury, death or property damage, real or personal, including loss of use thereof arising out of or as a consequence of the breach of any duty or obligations of the contracting party included in this agreement, negligent acts, errors or omissions, including engineering and/or professional error, fault, mistake or negligence of integrator, its employees, agents, representatives, or sub-Vendors, their employees, agents or representative in connections with or incident to the performance of this agreement, or arising out of Worker’s Compensation claims, Unemployment Compensation claims, or Unemployment Disability Compensation claims of employees of the company and/or its sub-Vendors or claims under similar such laws or obligations. Company obligation under this Section shall not extent to any liability caused by the sole negligence of the City, or its employees. Before beginning work, contract party shall file with the City a certificate from his insurer showing the amounts of insurance carried and the risk covered thereby. Liability insurance coverage must be no less than \$1,000,000. During performance, the company must have in effect and maintain insurance from a company licensed to do business in the State of Alabama. Coverage required includes 1) Comprehensive General Liability; 2) Comprehensive Automobile Liability; and 3) Worker’s Compensation and Employer’s Liability.

**17. STATEMENT OF COMPLIANCE WITH ALABAMA CODE SECTION 31-13-9:** By signing this contract, the contracting parties affirm, for the duration of the Agreement, that they will not violate federal immigration law or knowingly employ, hire for employment, or

continue to employ an unauthorized alien within the State of Alabama. Furthermore, a contracting party found to be in violation of this provision shall be deemed in breach of the Agreement and shall be responsible for all damages resulting therefrom.

18. **COMPLETE CONTRACT**: The above seventeen paragraphs or sections constitute the entire agreement. Any amendments or extensions must be made in accordance with the provisions stated herein.

THE GREATER BIRMINGHAM  
HUMANE SOCIETY ANIMAL  
CARE & CONTROL, LLC

CITY OF LEEDS  
A Municipal Corporation

\_\_\_\_\_  
Signature

\_\_\_\_\_  
Signature

\_\_\_\_\_  
Print

\_\_\_\_\_  
Print

\_\_\_\_\_  
Title

\_\_\_\_\_  
Title

\_\_\_\_\_  
Date

ATTEST:

\_\_\_\_\_  
CITY CLERK

**EXHIBIT A**

**Animal Control and Pound Services**

Price Sheet

**1. Animal Control Field Services**

A. Full time animal control vehicle (based on 40 hour work week)	\$ 7,083.00	per vehicle/per month
B. Animal control vehicle	\$ 327.00	per vehicle/per day
C. Animal control vehicle	\$ 41.00	per vehicle/per hour
D. After hours and weekend	\$ 61.50	per vehicle/per hour (1/2 hour minimum)

**2. Animal Boarding**

A. Weaned Animal	\$ 42.00	per animal/per total stay
B. Un-Weaned Animal	\$ 0.00	per animal/per total stay
C. Quarantined Animal	\$ 9.00	per animal/per day
D. Livestock	\$ 6.00	per animal/per day

**3. Pricing for Animals Seized Under the Authority of the Pet Protection Act**

A. Boarding	\$ 6.00	per day
B. Medical Care	\$ 12.00	total cost
C. Euthanasia	\$ 10.00	per animal

**4. Adoptions with Alteration**

A. Dog	\$ 60.00	per animal
B. Cat	\$ 50.00	per animal

**5. Rabies Test Preparation**

A. Office Bring In	\$ 7.00	per animal
B. Field Pick Up	\$ 11.00	per animal

**6. Out of County Surrenders**

A. Owned	\$ 15.00	per animal
B. Stray	\$ 20.00	per animal

**7. Euthanasia Service Only**

A. Euthanasia	\$ 10.00	per animal
---------------	----------	------------

**8. Law Enforcement Requested Service Not Mandated by Law or Local Ordinance**

A. Field Services: See Category 1 Above		
B. Boarding	\$ 26.00	per animal/per day
C. Euthanasia: See 3C Above		

**9. Animal Rescue Services**

A. Rabies Vaccination	\$ 6.00	per animal
B. Preventative Vaccines	\$ 15.00	per animal

Prices Quoted Per Amendment 2 of ITB 4-16

**Item Attachment Documents:**

23. Resolution 2020-01-02 Consider Awarding Bid for 2020 Brush Truck Fire Apparatus

# CITY OF LEEDS

## RESOLUTION NO.: 2020-01-02

### RESOLUTION AWARDING BID FOR 2020 4500 4X4 BRUSH TRUCK FIRE APPARATUS

**WHEREAS**, the Leeds Fire Department, previously advertised invitations to bid in regards to what is commonly referred to as the Brush Fire Apparatus bid; and

**WHEREAS**, the City did in fact receive three (3) qualified bids in response and as a result of the advertised Invitation to Bid; and

**WHEREAS**, from the bids received, as identified by the attached list, the Leeds Fire Chief Parsons has recommended that the City award the bid to NAFECO (see Exhibit A).

**NOW THEREFORE, BE IT RESOLVED**, by the City Council of the City of Leeds that:

1. The Recitals above are true, correct, approved and included herein as if fully set forth.
2. The 2020 4500 4x4 Brush Truck Fire Apparatus, is hereby awarded to NAFECO in the bid amount of \$125,498.00, for the Base Bid, subject to:
  - a. The full execution of the necessary Agreement as applicable; and
  - b. Compliance and in accordance with all terms and conditions of the Bid Documents and City Ordinances.
3. The Mayor and staff shall have the full authority to do those things, perform those functions, make such decisions, and to sign necessary documentation in order to carry out and fully complete the actions so authorized herein.

**ADOPTED and APPROVED** this the 6<sup>th</sup> day of January 2020

CITY OF LEEDS, ALABAMA:

\_\_\_\_\_  
David Miller, Mayor

\_\_\_\_\_  
DATE

**AYES:** \_\_\_\_\_

ATTEST:

**NAYS:** \_\_\_\_\_

**ABSENT FROM VOTING:** \_\_\_\_\_

\_\_\_\_\_  
Toushi Arbitelle, City Clerk

**ABSTAIN:** \_\_\_\_\_

I, Toushi Arbitelle, City Clerk of the City of Leeds, hereby certify that the above Resolution was duly adopted by the City Council of the City of Leeds at a regular meeting held on the 6<sup>th</sup> day of January 2020

\_\_\_\_\_  
City Clerk



Bid Summation  
2020 Brush Truck Fire Apparatus

177

<b>Company Name</b>	<b>Bid Accepted</b>	<b>Bid Rejected</b>	<b>Reason Bid Rejected</b>	<b>Lump Sum Bid</b>
Deep South Fire Trucks	Yes			\$128,212.00
Southeast Apparatus	Yes			\$134,900.00
NAFECO	Yes			\$125,498.00

## LEEDS FIRE DEPARTMENT

Bidder  
CompliesOfficial Bid Form

Name: Leeds Fire Department  
 Date: 12-27-2019  
 Time: 10:00 AM

We are pleased to submit the following bid for one (1) Brush Truck fire apparatus with all items and equipment per published specifications.

\$ 124,090.<sup>00</sup> each, (Figure Price), excluding federal, state and local taxes.

\$ 1,408.<sup>00</sup> Equipment Option

\$ 125,498.<sup>00</sup> Total Bid

The following questionnaire shall be completed by the bidder with the understanding that false or misleading information will be grounds for rejection of your bid.

Delivery shall be made in:

150 Days After  
Receipt of Chassis Calendar Days

Bid includes prepaid delivery of the vehicle to:

Leeds Alabama

Terms of Payment:

Upon Delivery

	YES	NO
Has the bidder taken any exceptions to the specifications?		<input checked="" type="checkbox"/>
Are all deviations from specifications explained as required by these specifications?	<input checked="" type="checkbox"/>	
Is a bid drawing enclosed of the exact body in these specifications?	<input checked="" type="checkbox"/>	
Will a production and approval drawing to be provided as required by these specifications?	<input checked="" type="checkbox"/>	
Has the bidder provided a detailed proposal in compliance with these specifications?	<input checked="" type="checkbox"/>	
Has the bidder complied with all specified warranties?	<input checked="" type="checkbox"/>	

Bidder:

NAFECO

Manufacturer

CET

Address:

1515 West Moulton St.

City, State, Zip Code

Decatur, AL 35601

Signature:



Title:

NAFECO Sales Rep.

179



**NAFECO**

Mailing: 1515 W Moulton St  
(2601 Beltline Road)  
Decatur, AL 35601  
(800) 628-6233  
info@nafeco.com

**Quotation**

Q319117991

Date: 11/7/2019  
Expires: 12/26/2019  
FOB: Destination

Customer Number: LEE075  
Customer Information: LEEDS FIRE DEPARTMENT  
Address: ATTN: CHARLES PARSONS  
1040 PARK DRIVE  
LEEDS, AL 35094

Attention: Kyle Shell  
Phone: 205-368-0533  
Email: ffshell04@gmail.com  
Prepared By: John Wilson

Qty.	Product	Description	Each	Total
1	/BRUSH TRUCK	NAFECO/CET Brush Truck 2020 Two Door Dodge 4 X 4, 300 Gallon Skid Unit w/ Kubota Diesel Pump. See Attached Specs	\$124,090.00	\$124,090.00
1	44315	Streamlight Vulcan 180 Light 12V DC, Orange	\$179.00	\$179.00
2	FR	Flamefighter Fire Rake 60", Fiberglass Handle	\$49.00	\$98.00
2	FF	Flamefighter Fire Flap, Fiberglass Handle, 5'	\$49.00	\$98.00
2	PUL	Flamefighter Pulaski Axe, 36", FG Handle, 3.5 lb	\$49.00	\$98.00
2	85130	Peco Collapsible Backpack, Indian 5 Gallon Complete	\$188.00	\$376.00
1	/04000034	Elkhart 1" Chief Legacy Nozzle w/ Pistol Grip 60 GPM @ 100 PSI	\$559.00	\$559.00
			<b>Total: \$125,498.00</b>	
			<i>tax &amp; freight to be determined</i>	

Notes: Price Includes Delivery

**Thank you for your business!**

*NOTE: All accounts are subject to sales tax charges unless a valid state exempt certificate is on file with NAFECO, or provided at the time of the order.*

If you have any questions concerning this quote, please call our number listed above.

Visit Us On The Internet At: [www.nafeco.com](http://www.nafeco.com)

**GENERAL TERMS AND CONDITIONS****Invitation to Submit Sealed Bids**

Date of Bid: December 27<sup>th</sup> 2019

Time of Bid: 10:00 am

At the above date and time, sealed bids will be accepted for:

**One (1) Brush Fire Apparatus mounted the specified chassis**

Complete apparatus must be built in accordance with the recommendations of the National Fire Protection Association #1901 Standard in its latest edition. The officials of the purchaser reserve the right to accept the bid they deem is in the best interest of the purchasing entity and/or fire department. The purchaser shall be the final authority in determining compliance with the specifications. Questions concerning the technical specifications shall be directed to:

Contact: Chief Charles Parsons

Phone: 205-699-0912

Bids shall be sealed and marked "Proposal for Brush Truck," along with the date and time of the bid opening. The award will be made to the lowest responsible bidder meeting the requirements of the specifications. The purchaser shall not be responsible for bids opened in error which are incorrectly or inadequately marked.

No bid may be withdrawn for a period of thirty (30) days. All documents and bid forms required by the specifications shall be submitted in the original bid. No additions or modifications will be allowed after bids are opened.

The purchaser reserves the right to reject any or all bids with or without cause. Specifications are on file in the office of the Purchaser.

Return Bids to: City of Leeds City Hall

Street Address: 1400 9<sup>th</sup> Street

City, State, Zip Code: Leeds, AL 35094

Bids will be opened at this location

## LEEDS FIRE DEPARTMENT

Bidder  
CompliesWarranties

This specification makes reference to various warranties which are the minimum acceptable in each case. Each bidder shall also include reference which acknowledges each component and overall apparatus warranty. Bidders must include copies of each warranty provided by various component manufacturers.

Quotation Drawings

The bidder has included quotation and evaluation "proposal drawings" that reflect the basic concept of the proposed vehicle. These drawings do not reflect all equipment proposed and written specifications shall prevail.

Approval and Production Drawings

Prior to construction, the bidder shall submit final approval and production drawings for the purchaser's evaluation and written approval. After signing, the approval drawings shall be returned to the bidder with an authorization letter to proceed with construction.

Clarifications and Exceptions to Specifications

Any Clarifications or Exceptions to the Specifications shall be listed on a separate page listing the page number and subject of specification. A detailed description shall be given for the clarification or exception.

Compliance to State and Federal Motor Vehicle Requirements

The proposed vehicle and it's design, operational and material features shall fully comply with State and Federal Motor Vehicle Standards and applicable National Fire Protection Association standards.

Aluminum Body and Quality Construction

The body and compartments for this specified vehicle shall be of all aluminum construction in compliance to purchaser's specifications or with noted clarifications. The highest of construction and manufacturing quality assurance standards are maintained by the contractor.

Construction Period

The delivery of the vehicle shall be: 150 calendar days after receipt of the chassis.

The bidder shall not be responsible for delays in delivery due to strikes, acts of God, failure of suppliers to deliver, chassis shortage and other reasons beyond the reasonable control of the builder. Should the bidder be unable to comply with the proposed delivery date, the purchaser shall be notified immediately with the reasons for non-compliance.

Familiarization and Demonstration of Vehicle

The dealer shall familiarize and demonstrate the vehicle to the purchaser at the fire department. This shall include operation of chassis, major components, review of delivery information and documentation.

FIRE APPARATUS SPECIFICATIONSCHASSIS SPECIFICATIONSCOMMERCIAL CHASSIS

The chassis shall be a new, unused commercial cab and chassis drop shipped to the apparatus body manufacturer's production facility.

**Dodge Cab & Chassis** Unit is to be installed on a Dodge RAM 3500, 2020, 2-Door Regular Cab, 4 x 4. The power train should consist of the following:

- GVWR: 14,000 lbs.
- 6.7L I6 Cummins turbo diesel engine (ETN)
- 6-speed AISIN heavy-duty automatic transmission (DF2)
- Emergency/fire/rescue special emissions package (AH6)
- Tradesman level 1 equipment group (A61)

Interior requirements are as follows:

- Air conditioning with high output fresh air heater
- Am/Fm Stereo/digital clock and 2 speakers
- HD vinyl 40/20/40 split bench seat

Exterior requirements are as follows:

- The chassis shall be painted by the chassis manufacturer according to the chassis manufacturer's factory standards.
- Cab to be Dodge Flame red (PR4)
- Dual front tow hooks
- The chassis exhaust system shall be extended to the rear of the right rear wheel.
- The wheel base shall be 145" wheelbase, Cab to Axle (C.A.) should be 60"
- LT235/80R17E on/off road tires
- Dual rear wheels

Major Standard

Features:

- Brakes – Anti-lock System (ABS)
- Grab handles – Driver and front passenger
- Power steering
- Roof clearance lights
- Windshield wipers – interval

Dodge

Warranty:

- 3 years 36,000 miles bumper to bumper
- 5 years 60,000 miles Transmission
- 5 years 100,000 miles motor

LEEDS FIRE DEPARTMENT

Bidder  
Complies

**Inside Doors Reflective** All driving and crew compartment doors shall have at least 96 in2 of reflective material affixed to the inside of each door.

**Black Side Step Bars** One (1) set of 3" round black powder-coated finish side step bars. Steps shall be constructed from stainless-steel.

**Ranch Hand Sport Black Front Bumper** The OEM bumper shall be removed and replaced with a Ranch Hand Sport black powder coated front bumper contoured to follow the shape of the grille and body. The bumper shall be protected vehicle's grille area and the vehicle's headlamps and be winch-ready.

**Warn Winch M12 (12,000#)** There shall be a 12,000 lbs. WARN M12 12 Volt; self-recovery electric winch. This winch will be permanently mounted in to the front bumper and wired per the manufacturer's specification. The winch shall have a 125' of 3/8" wire rope with a hook. The winch cable will pass through a 4-way roller fairlead.

Feature of the winch will include a 3-stage planetary gear system for fast line speed, cam action clutch disengages planetary gear system for free spooling and automatic load holding brake for strength and reliability.

**Flat Bed Body** One (1) custom Fire Application aluminum flatbed body, 110" long x 94-5/8" wide. The aluminum plate used in construction is .100" 3003-H22 polished aluminum alloy treadplate.

Body sub-frame is made from 6061-T6 aluminum tubes and channels. Sub-frame crossmembers are installed every 16". The channel is 1-1/2" wide x 3" high x 3/16" thick. The body crossmembers shall extend the full width to support the compartment framing and shall be welded to the sub-frame main members.

The Body sub-frame main members consist of 6061-T6 Aluminum square tubing of 2" wide x 6" high x 3/16" thick.

The perimeter shall be made with 1/8" thick forged 3003H14 Aluminum. Forged aluminum brings a strong design that was specially made to embed emergency lighting & designed to fit properly a 4" reflective stripping.

The body shall be attached to the chassis rails with a minimum of four (4) heavy duty "U" bolts. The body shall be separated from the chassis by 3/8" Teflon. Attachment of the body and sub-frame will allow the body to resist from all distortion and off-road operational condition.

The body is a modular design to allow removal from the chassis for major repair or mounting on a new chassis. Isolating material between the body and the chassis to be installed

All welding shall be done electrically using 5356 aluminum welding wire.

Rear vertical skirt will be made from 1/8" 3003-H22 polished aluminum alloy treadplate.

Rear skirt to include Signal, brake, reverse lights, D.O.T., license plate & NFPA steps.

Clearance, marker, license plate lights and reflectors will be furnished and installed per D.O.T.

Junction box supplied and installed under the flat bed.

License plate light shall be an Eon light with SS polish case that has a light output equivalent to a 10-watt halogen lamp. Eon light to have a 50,000 hrs. LED life.

LED Signal, brake and reverse lights will be High Quality Grote Automotive lights recessed mount into rear aluminum skirt area of body per FMVSS 108 and CMVSS 108 requirements. Light to be LED Oval

✓  
✓  
✓  
✓  
✓  
✓

with chromed housing.

Two (2) LED Amber marker/clearance lights with chrome housing and clear lens will be installed on the front side of the bed, one (1) each side. Two (2) LED Red marker/clearance lights with chrome housing and clear lens will be installed on the rear side of the bed, one (1) each side. Three (3) LED Red marker/clearance lights with chrome housing and clear lens will be installed at the rear center of the bed. Amber & Red reflectors shall be installed around the perimeter of the bed as per DOT requirement.

Two (2) heavy duty tow eyes shall be installed at the rear of the body (NFPA 1906 requirement). The tow eyes will be fastened directly to each rear chassis frame rail. Hardware shall have a clear and unobstructed access.

The rear of the flat bed shall have two (2) non-skid rear steps for access to pump and controls. The rear steps shall be made so it can be folded up for use in rough terrain. All steps shall sustain a minimum static load of 500 lbs. (227 kg) without deformation (NFPA 1906 & 1901 compliant).

An angle of approach and an angle of departure of at least 20 degrees shall be maintained at the front and the rear of the vehicle when it is loaded.

This will be no exception to the body specifications. Pre-built commercial flatbed bodies are not acceptable.

**Right side Integrated Pre-Connect Hose Tray** Integrated on the right side of the flat bed body, one (1) enclosed pre-connected hose tray made from aluminum to hold a minimum of 150' of 1-3/4" hose. Hose Tray to have a flip down door with latches. Tray design shall allow hoses to pay out in any direction and quick hose storage when finished.

Hose tray shall have a 1-1/2" Pre-Connect elbow.

The area shall be designed to prevent the accumulation of water and allow for ventilation to aid in drying hose in the storage area. Black Turtle Tiles to be installed and bolted on the floor.

#### **Left Side Integrated Pre-Connect Hose Tray**

Integrated on the left side of the flat bed body, one (1) enclosed pre-connected hose tray made from aluminum to hold a minimum of 150' of 1-3/4" hose.

Hose Tray to have a flip down door with latches. Tray design shall allow hoses to pay out in any direction and quick hose storage when finished.

Hose tray shall have a 1-1/2" Pre-Connect elbow.

The area shall be designed to prevent the accumulation of water and allow for ventilation to aid in drying hose in the storage area. Black Turtle Tiles to be installed and bolted on the floor.

**Compartments** All compartments will be made with 1/8" tread plate aluminum sheet.

All compartments shall have a minimum of one (1) louvered panel bolted into a wall to provide the proper airflow inside the compartment.

All compartments shall be of sweep-out type with no lip at bottom edge for easy cleaning.

**Transverse Compartment** One (1) transverse compartment of 13-1/2" long x 22" high x 94" wide shall be installed. Each side door shall be horizontally hinged, drop down style with retaining cables. The overlap aluminum diamond plate compartment doors shall be securely attached to the body with a full stainless-steel hinge. Door openings shall be fitted with solid neoprene weather strip completely sealing the perimeter of the compartment door opening. The drop-down door shall be retained with cable. Compartment door seams is sealed with a pliable automotive body caulking. The compartment door is latched with recessed, polished stainless steel "D" ring handles and locks.

**Top Transverse Storage Hose Tray** One (1) aluminum storage hose tray shall be supplied and installed on top of the transverse compartment.

The dimensions of the storage tray shall be full length of the top compartment, 94" L x 9- 3/8" W x 8" H.

The area shall be designed to prevent the accumulation of water and allow for ventilation to aid in drying hose in the storage area. Black Turtle Tiles to be installed and bolted on the floor. The storage



tray shall be covered with black canvas and rear net.

**Left (Driver) Side Compartment** One (1) 62" long x 30" high x 22" deep compartment behind the chassis, located at the left (driver) side of the water tank.

The overlap aluminum compartment doors shall be securely attached to the body with a full stainless-steel hinge. Door openings shall be fitted with solid neoprene weather strip completely sealing the perimeter of the compartment door opening. Lift up doors shall be installed with gas hold open struts.

The 1/8" compartment doors are latched with a recessed polished stainless steel "D" ring handles and locks. The aluminum doors complete with the following features: door ajar switch and two (2) LED strip lights.

One (1) switch shall be installed so the compartment light(s) shall come on only when compartment door is open.

There shall be a set of tracks for future installation of adjustable shelf(s) in each compartment. These tracks shall be installed vertically on the walls of the compartment(s) and shall offer a multitude of height adjustment possibilities.

The compartment floor will be covered with Plastic Tiles. The tiles shall be black with yellow angled leading edges.

**Right (Passenger) Side Compartment** One (1) 62" long x 30" high x 22" deep compartment behind the chassis, located at the left (driver) side of the water tank.

The overlap aluminum compartment doors shall be securely attached to the body with a full stainless-steel hinge. Door openings shall be fitted with solid neoprene weather strip completely sealing the perimeter of the compartment door opening. Lift up doors shall be installed with gas hold open struts. The 1/8" compartment doors are latched with recessed, polished stainless steel "D" ring handles and locks.

The aluminum doors complete with the following features: door ajar switch and two (2) LED strip lights. One (1) switch shall be installed so the compartment light(s) shall come on only when compartment door is open.

There shall be a set of tracks for future installation of adjustable shelf(s) in each compartment. These tracks shall be installed vertically on the walls of the compartment(s) and shall offer a multitude of height adjustment possibilities

The compartment floor will be covered with Plastic Tiles. The tiles shall be black with yellow angled leading edges.

**Rear Storage Compartment** One (1) integrated to the platform compartment approximately 5" high x 24" wide x 104" long for suction hose storage and folding ladders or pike poles. A flip down horizontally hinges door is furnished at the rear. The interior compartment is made from polished 3003-H14 alloy smooth plate.

**Wheel Chocks** Medium Kochek Wheel Chocks with storage brackets shall be provided and mounted underneath the flatbed behind the chassis cab.

**Rear Mud Flaps** Rear rubber mud flaps are provided. A bracket attached to the side of the muffler pipe end is installed to prevent any damaged that can occur to the mud flap.

#### Electrical Components

A 12-volt electrical system is supply.

The wiring is secured in place, readily accessible and protected against heat, water and physical damage.

Electrical harness lines shall be mechanically attached to the frame or body structure of the apparatus. All wiring will be run in heat and moisture resistant plastic convoluted split loom.

Electrical harness lines shall be furnished with protective looms, grommets, or other devices at each

point where they pass through body panels or structural members or wherever they lie against a sharp metal edge. A through-the-frame connector shall be permitted to be used in place of metal protective looms or grommets.

Switches, relays, terminals, and connectors shall have a direct current (dc) rating of 125 percent of maximum current for which the circuit is protected.

Conductor insulation will conform to S.A.E. requirements. All circuit are protected by automatic reset circuit breakers.

All wiring furnished will conform to the national Electric Code.

All circuits will be wired in conformance with S.A.E. J1292, Automobile wiring standard.

All wiring will be function worded schematically.

An electric diagram will be remit upon delivery.

**Console** One fire application custom console installed between seats with rocker switch. To be quickly identified and visible to the driver and passenger while seated, the rocker switches shall be installed on the top face of the console designed with a 40° angle. This area shall be able to hold at least two rows of rocker switch. All switches shall be appropriately identified by panel mounted legends.

The first lighted rocker switch shall be a red Master Optical Warning switch. A master body disconnect automatic switch, normally open contacts, shall be provided to disconnect all electrical loads not provided by the chassis manufacturer. The starter solenoids shall be connected directly to the batteries.

All rocker switches to have a green "On" indicator that is visible from the driver's position shall be provided.

The console has an area to accommodate department map books, clipboards etc.

The console has an area for one (1) radio heads & Siren installation.

All electrical components will be installed customized console and protected with an aluminium box. This console will be design to easily gain access to those breakers, relays, wiring, etc.

Controls and switches that are expected to be operated by the driver while the apparatus is in motion shall be within convenient reach for the driver.

Console shall be painted black scratch free Herculiner finish.

**Emergency Lighting** One (1) 56" LED Whelen Justice Lightbar, model #JE2NFPA shall be mounted on the headrache rack and controlled by one (1) switch on the cab console.

- 4 x Red SUPER LED Corners
- 4 x Red SUPER LED Inner
- 2 x White SUPER LED Inner

For Blocking Right-of-Way Mode of operation, white Super LED Inner lights (2) shall be turned off when the transmission is on Park position.

Mounted on front chassis grill, Two (2) Whelen Ion-T series Super LED, one (1) each side, red with clear lens with a chrome flange.

Mounted on sides of the chassis, Two (2) Whelen Ion-T series Super LED, one (1) each side, red with clear lens with a chrome flange.

Mounted on sides of the flatbed, Two (2) Whelen M4 series Linear Super LED, one (1) each side, red with clear lens with a chrome flange.

Mounted in the rear of the flatbed, Two (2) Whelen M4 series Linear Super LED, one (1) each side, red with clear lens with a chrome flange.

All emergency lights shall be connected and controlled by one (1) switch on the cab console.

**Siren & Speaker** One (1) Whelen, model #295SLSA1, 100-watt electronic siren amplifier with PA and switch control center to be provided and installed. Siren shall have wail, hyper-yelp and air horn tones as well as public address and shall be capable of radio rebroadcast.

One (1) Whelen, model #SA315P, 100-watt speaker, shall be provided and mounted on the front bumper with a mounting bracket.

**Two (2) Telescopic Scene Lights FCA512-D30-ON** Two (2) 300W telescoping 12v scene lights

LEEDS FIRE DEPARTMENT

Bidder  
Complies

mounted at the front of the flatbed. The light shall be single head design. One light mounted on each side will increase visibility around the apparatus during night or light operations. Model is to be Fire Research FCA512-D30- ON. A switchbox is provided underneath each lamp head.

**Battery Charger** One (1) Auto Charger Kit, single battery system, 18 amps, 12 volts shall be provided and installed in the chassis cab on the floor, under the rear seat on the driver side.

The Auto Charge kits include the Automatic battery charger, circuit breaker & ground fault protected outlet to power accessories on the vehicle and Super Auto Eject with water proof cover. Brand shall be Kussmaul, Auto Charge 1000 model.

**Compartment Lights Switches** One (1) switch per compartment shall be installed so the compartment light(s) shall come on only when compartment door is open.

**Door Ajar** One (1) door ajar warning light shall be provided and installed in the console to indicate an open body compartment door. The light shall be properly marked with a sign "Warning Door Ajar".

**Back-Up Alarm** One (1) back-up alarm that meets the type D (87 dBA) requirements of SAEJ994 shall be provided at the rear of the apparatus. It will activate when the transmission is placed in reverse.

**Drop-In-Unit Tank**

The water tank shall be constructed of 1/2" thick polypropylene sheet. The material shall be of a certified, high quality, non-corrosive, stress relieved thermos plastic, black in colour with a textured finish, and UV stabilized for maximum protection. The skid type booster tank shall be of a standard configuration and shall be so designed to have complete modular slide in capability. All joints and seams are to be fully welded and electronically tested for maximum strength. The unit shall incorporate transverse partitions manufactured for 1/2" polypropylene which shall interlock with a series of longitudinal partitions constructed of 1/2" polypropylene. All swash partitions shall be so designed to allow for maximum water and air flow between compartments and are fully welded to each other as well as to the inside of the tank.

The passenger side rear wall of the tank shall have a standard built in sight gauge 2" in width, and 70% transparent.

Tank will be baffles in accordance with NFPA bulletin 1906 requirements, latest version.

**Fill tower and tank cover** The tank shall be equipped with a combination vent/overflow and manual fill tower. The fill tower shall be an 8" round by 6" high with a moulded drop-on type cover. The cover shall be attached to the tower with a rope to prevent loss. The tower shall be located in the right rear corner of the tank. There shall be a vent / overflow installed inside and to the extreme rear of the tower approximately 2" down from the top. This vent / overflow shall be of a standard schedule 40 polypropylene pipe with minimum ID of 3". The vent / overflow shall be piped internally and exit out at the passenger side tank wall with a 1" extension past the wall.

The tank cover shall be constructed of 1/2" thick polypropylene, black in color, UV stabilized.

**Tank Capacity** The tank shall have a capacity of 300 U.S. gallons of water. The tank shall be covered by the ALL-OUT No-Fault Life Time Warranty.

**Sump** The floor of the tank shall be manufactured from 3/4" polypropylene. There shall be one (1) sump as standard per tank. The sump shall be integral to the tank floor and be a minimum of 1/2" deep recessed into the floor. The sump shall not be visible from or protrude through the bottom of the tank.

**Tank Outlets** There shall be two standard tank outlets located in the same vertical plane on the driver side rear wall of the tank. One (1) 2-1/2" female NPT tank to pump suction fitting and one (1) 1-1/2" female NPT tank fill fitting with flow deflector

**1" Tank Drain** There shall be a 1" tank drain to the rear right side of the tank with a plug.

**Tank Mounting Blocks**

The cover shall incorporate two (2) booster reel mounting blocks that shall be to accommodate two (2) each sliding nut fasteners. These mounting blocks shall be welded to the covers running from the rear edge of the tank forward.

**Skid Base** There shall be a full width skid base manufactured of 3/4" polypropylene welded to the tank. This base shall be 48" wide by 96" long and shall extend 34" past the tank in the rear to allow for pump mounting. The pump mounting area shall be supported by 1/2" polypropylene gussets 15" high by 32" long. The gussets shall be equipped with 2" holes to assist in lifting the unit.

**Mounting** The Drop-In-Unit shall be mounted in a manner that allows access to the engine, pump, and auxiliary systems for routine maintenance. The Drop-In-Unit shall not be welded or otherwise permanently secured to other components.

The mounts shall allow for the truck to be secured directly to a truck bed without the need for any skid frame work underneath.

**Fire Pump, PFP-21hp-DSL-MR** The pump shall be a CET PFP-21hp-MR single stage centrifugal pump, bolted directly to the engine, with a 2.5" victaulic suction inlet, and a 1.5" flange discharge outlet.

The volute and pump head shall be a lightweight, high strength, seawater resistant, aluminum alloy. The impeller shall be a bronze enclosed type for maximum efficiency, fully machined and balance. The shaft seal shall be self-adjusting, self-lubricating, and mechanical type.

The pump piping shall be flexible to prevent any breakage caused by vibration.

The pump shall be capable of a maximum discharge volume of 275 GPM at 10 PSI, and a maximum discharge pressure of 175 PSI while pumping 60 GPM. In the center of the performance curve, the pump shall be capable of pumping 250 GPM at 50 PSI and 95 GPM at 150 PSI. Pump to be mounted at rear.

The performances are based on a maximum altitude of 500ft and any higher elevation will lower the pump performance. The standard engine performance drops are 3% for every 1000 feet.

**Engine**

The pump shall be driven by a 3-cylinder, DIESEL engine powered, Kubota 21 horsepower engine. The engine shall be water cooled, with a 12-volt electric start.

The engine shall be connected to the battery of the chassis and shall be connected to the fuel tank of the chassis with a low-pressure, 2-4 psi, 12 VDC fuel pump connected to the ignition of the pump engine.

**Deluxe Pump Control panel** A Deluxe Control Panel shall be supplied and installed on the pump. The Control Panel shall be manufactured from aluminum and completely covered with a black plastic plate. The Control Panel shall consist of a unkeyed start switch, engine stop, oil pressure, glow plug and engine temperature warning lights, 2.5" diameter pump discharge and pump intake liquid filled pressure gauges, primer control, throttle lever and illumination for controls with the installation of one new design tube light. All pump controls and gauges shall be properly marked with white letters engrave in the black plastic plate.

**Exhaust Primer** The pump engine shall be equipped with a quieter exhaust venturi type primer capable of 15' – 20' lift for fast positive priming. The control for the primer shall be capable of being operated by a person operating controls at the primary pump operator's position.

**Plumbing and Valves** Intake and discharge piping shall not interfere with the routine maintenance of the pump, engine, or auxiliary systems and shall not unduly restrict the servicing of these components.

**Steel Suction Piping - 2.5" - Two (2) Fire Type Swing-Out Valves** All piping on the suction side shall be made of steel (welded joints) painted red. The suction piping, the pump and the discharge shall be tested to 400 PSI.

The suction piping shall consist of a 2.5" tank to pump line with a 2.5" flexible rubber hump hose to minimize flex and vibration between the pump and the tank.

RIGID PIPING SHALL NOT BE ACCEPTABLE.

Between the tank and the pump there shall be a 2.5" fire type swing-out valve. This valve shall remain open to pump from the tank.

This pipe shall have a tee into the suction side of the pump and shall continue to the rear of the truck for overboard suction where there shall be an additional 2.5" fire type swing-out valve.

The overboard suction connection shall have a 2.5" NST female swivel adapter and a 2.5" NST plug with retaining cable.

To draft, the tank to pump valve shall be closed, a suction hose connected to the overboard suction connection and placed in a static water supply, and the primer activated.

#### Steel Discharge Piping

All piping shall be steel piping or high-pressure flexible hose. A 2.5" X 2.5" square steel manifold shall be piped directly to the discharge outlet of the pump. Attached to this discharge manifold, by means of welded steel pipe nipples, shall be all the discharge valves. All piping shall be painted red to match the pump.

The discharge shall be equipped with a drain valve at the lowest point.

**1" Tank Fill** There shall be a 1" valve piped from the discharge manifold as a means for refilling the tank. The valve shall be a fire type quarter turn swing-out valve handle and 1" NPT threads, and shall be connected to the tank fill port by 1" high pressure flexible hose.

**One (1) 1" Discharge to Rear** There shall be one (1) 1" valve piped from the discharge manifold to the rear of the truck for connection of forestry hose. The valve shall be a fire type quarter turn swing-out valve with 1" NST threads. The valve shall be furnished with a garden hose (GHT) cap and chain.

**One (1) 1.5" Discharge to Rear** There shall be one (1) 1.5" valve piped from the discharge manifold to the rear of the truck for connection of forestry hose. The valve shall be a fire type quarter turn swing-out valve with 1.5" NST threads. The valve shall be furnished with a 1.5" NST cap and chain.

**One (1) 1" Discharge to Booster Reel** There shall be 1" valve piped from the discharge manifold to the booster reel. The valve shall be a fire type quarter turn swing-out valve handle and 1" NPT threads and shall be connected to the reel by 1" high pressure flexible hose.

**One (1) Booster Hose Reel** One (1) 12v electric rewind booster hose reel capable of handling 200' of 1" diameter booster hose. The reel shall have a push button rewind control and a backup geared crank rewind handle. The reel shall be equipped with a 1" NPT 90° swivel inlet, and a 1" NST outlet riser. The reel shall be manufactured of steel and shall be primed and painted red. The reel shall be installed on the rear right corner of the flatbed, facing rear.

One (1) high mounted roller and spool assembly shall be furnished and installed on the reel. 200' of 1" rubber booster hose shall be supplied and installed on the reel.

**Two (2) 1.5" Discharges to Pre-Connected Hose Trays** Two (2) 1.5" valves piped from the discharge manifold to each pre-connected integrated hose tray. The valves shall be fire type quarter turn swing-out valves with handles and connected to each pre-connected hose tray by 1.5" high-pressure flexible plumbing.

**Testing** The pump shall be tested after the pump and all its associated piping and equipment have been installed on the fire apparatus. The tests shall be conducted at the manufacturer's approved facility. The testing shall include at least the pumping tests, the priming device test, the vacuum test. The water tank-to-pump flow test, and the piping integrity test.

General Instructions

The fire apparatus and equipment to be furnished in meeting these specifications shall be the product of an established, reputable fire apparatus manufacturer. Each bidder shall furnish satisfactory evidence of the manufacturer's ability to construct, supply service parts and provide technical assistance for the apparatus specified. The bidder must state the location of the factory and the location of the service center as well as the availability of on-site service.

Proposal Submission

Bids shall be addressed and submitted in accordance with the instructions provided on the bid advertisement cover sheet. The words "Proposal for Fire Apparatus", the date of the bid opening, and the time of the bid opening shall be stated on the front of the bid envelope.

Only the specified firefighting and support equipment listed in these specifications shall be provided. Any additional equipment required for standards compliance shall be provided by the purchaser after delivery.

The equipment proposed in response to this Invitation shall be new, unused, and shall be of the latest model and type unless otherwise specified.

The intent of these specifications is to describe the minimum quality level acceptable. Any brand name and/or model number mentioned is intended to be descriptive and not restrictive to bidders who cannot provide those specific brands. Each bidder must state the brand of any item which is not available to the bidder along with a complete description of the substituted item on a separate "exception sheet". The purchaser reserves the right to require a bidder to provide proof in each case that a substituted item is equal to the item specified. The purchaser shall be the sole judge in determination of acceptable substitutes and that decision shall be final.

The purchaser reserves the right to initiate and/or consider negotiations in construction which will be in the best interest of the purchasing entity and/or fire department once the bid has been awarded. Such negotiations will be subject to approval by the purchasing authority.

A bidder shall submit only one bid which meets or exceeds the specifications. Bids which option pricing or omit items required by the specifications in order to appear low bid will be rejected without consideration. Bids on alternate, stock or demonstrator units which do not meet these specifications are not being solicited and shall not be considered.

The purchaser shall utilize the proposal to compare the unit proposed with the specifications. All bid proposals are requested to be submitted in the "same sequence" as the advertised specifications for ease of comparison.

Any bidder who fails to submit a detailed construction specification or who photocopies and submits these specifications as their own construction details will be considered non-responsive, and such proposals shall be ineligible for award. Any erasures, strike-overs and/or changes to prices written in numerals should be initialed by the bidder. Failure to initial changes may be cause for rejection of the bid as irregular. All bids must be signed by a legally authorized representative of the company. The purchaser shall not accept a bid which has not been signed by a representative of the bidder.

Bidders shall be responsible for prompt arrival of the bid at the location designated in the specifications. Late proposals, telegrams, facsimile, or telephone bids shall not be considered. Bids shall also not be considered from firms, individuals or the same owners of separate companies submitting more than one bid.

## LEEDS FIRE DEPARTMENT

Bidder  
Complies**Loose Equipment**

The following loose equipment shall be provided on the apparatus.

- One (1) 44315 Streamlight Vulcan 180 12V DC LED Light
- Two (2) 60" Fire Rake with Fiberglass Handle
- Two (2) 60" Fire Flap with Fiberglass Handle
- Two (2) Pulaski Axe with Fiberglass Handle
- Two (2) Collapsible Back Pack Pump
- One (1) Elkhart 1" Chief Nozzle with Pistol Grip, 60 GPM @ 100 PSI

**General Warranty**

Apparatus warrants to the original purchaser I, at its election, either replace or repair any part of the new equipment sold to the purchaser hereunder which has been given no abnormal use; and which has received proper maintenance; and which is determined by the Apparatus Manufacturer to be defective in material or workmanship; and which has, within one (1) year after delivery to the purchaser be returned at the purchaser's expense, with transportation charges prepaid, to the Apparatus Manufacturer factory OR which has, within one (1) year after delivery to the purchaser, been pre-approved by the Manufacturer for a third-party to perform the work. All problems shall be reported to the Apparatus Manufacturer in writing and damaged parts shall be returned to the Apparatus Manufacturer .

**Fire Pump Warranty**

Manufacturer warrants to the original purchaser that the Manufacturer will, at its election, either replace or repair any part of the Pump sold to the purchaser hereunder which has been given no abnormal use; and which has received proper maintenance; and which is determined by the Manufacturer to be defective in material or workmanship; and which has, within three (3) years after delivery to the purchaser be returned at the purchaser's expense, with transportation charges prepaid, to factory OR which has, within three (3) years after delivery to the purchaser, been pre-approved by the Manufacturer for a third-party to perform the work. All problems shall be reported to the Manufacturer in writing and damaged parts shall be returned to the Manufacturer.

**Water Tank Warranty Limited Lifetime**

Manufacturer warrants each water and/or foam tank to be from manufacturing defects in material and workmanship for the service life of the original vehicle. Every tank shall be thoroughly inspected and tested for leaks before leaving our facility and must be installed in accordance with the guidelines. Manufacturer will repair or, at its option, replace the tank with a new tank. Manufacturer will cover customary and reasonable costs to remove and install the tank. This warranty will not cover the tanks that have been improperly installed, misused, or abused. The serial number must not have been altered, defaced or removed. Manufacturer will not cover any unauthorized third-party repairs or alterations. Any of these actions may void the warranty.

There are no warranties, expressed or implied, which extend beyond the description of the face, hereof. There is no express or implied warranty of merchantability or a warranty of fitness for a particular purpose. Additionally, this warranty is in lieu of all other obligations or liabilities on the part of the Manufacturer.

This warranty contains the entire warranty. It is the sole warranty and price agreements or representation, whether oral or written, are either merged herein or expressly canceled. the Manufacturer neither authorizes any person supposing to act on its behalf to change, nor assume for it, any warranty or liability concerning its product.

In no event will the Manufacturer be liable for an amount in excess of the currently published retail

**LEEDS FIRE DEPARTMENT**

**Bidder  
Complies**

price plus installation and removal cost of the tank, for any loss or damage, whether direct or indirect, incidental, consequential, or otherwise arising out of failure of its product.

This warranty gives you the specific legal rights, and you may also have other rights which vary from state to state. Some states do not allow exclusion or limitation of incidental or consequential damage, so the above limitation or exclusion may not apply to you. Since some states do not allow limitations on the length of an implied warranty, the above limitation may not apply to you.





# Leeds Fire Department

## NAFECO/CET Reply Specifications

### Dodge Cab & Chassis

Unit is to be installed on a Dodge RAM 3500, 2020, 2-Door Regular Cab, 4 x 4.

The power train should consist of the following:

- GVWR: 14,000 lbs.
- 6.7L I6 Cummins turbo diesel engine (ETN)
- 6-speed AISIN heavy-duty automatic transmission (DF2)
- Emergency/fire/rescue special emissions package (AH6)
- Tradesman level 1 equipment group (A61)

Interior requirements are as follows:

- Air conditioning with high output fresh air heater
- Am/Fm Stereo/digital clock and 2 speakers
- HD vinyl 40/20/40 split bench seat

Exterior requirements are as follows:

- The chassis shall be painted by the chassis manufacturer according to the chassis manufacturer's factory standards.
- Cab to be Dodge Flame red (PR4)
- Dual front tow hooks
- The chassis exhaust system shall be extended to the rear of the right rear wheel.
- The wheel base shall be 145" wheelbase, Cab to Axle (C.A.) should be 60"
- LT235/80R17E on/off road tires
- Dual rear wheels

Major Standard Features:

- Brakes – Anti-lock System (ABS)
- Grab handles – Driver and front passenger
- Power steering
- Roof clearance lights
- Windshield wipers – interval

Dodge Warranty:

- 3 years 36,000 miles bumper to bumper

- 5 years 60,000 miles Transmission
- 5 years 100,000 miles motor

#### **Inside Doors Reflective**

All driving and crew compartment doors shall have at least 96 in<sup>2</sup> of reflective material affixed to the inside of each door.

#### **Black Side Step Bars**

One (1) set of 3" round black powder-coated finish side step bars. Steps shall be constructed from stainless-steel.

#### **Ranch Hand Sport Black Front Bumper**

The OEM bumper shall be removed and replaced with a Ranch Hand Sport black powder coated front bumper contoured to follow the shape of the grille and body. The bumper shall be protected vehicle's grille area and the vehicle's headlamps and be winch-ready.

#### **Warn Winch M12 (12,000#)**

There shall be a 12,000 lbs. WARN M12 12 Volt; self-recovery electric winch. This winch will be permanently mounted in to the front bumper and wired per the manufacturer's specification. The winch shall have a 125' of 3/8" wire rope with a hook. The winch cable will pass through a 4-way roller fairlead.

Feature of the winch will include a 3-stage planetary gear system for fast line speed, cam action clutch disengages planetary gear system for free spooling and automatic load holding brake for strength and reliability.

#### **Rear Hitch Class III**

A rear mounted Class III trailer hitch shall be securely attached to the chassis frame and shall include the 7-pin wiring trailer harness.

#### **CET Flat Bed Body**

One (1) custom Fire Application aluminum flatbed body, 110" long x 94-5/8" wide. The aluminum plate used in construction is .100" 3003-H22 polished aluminum alloy treadplate.

Body sub-frame is made from 6061-T6 aluminum tubes and channels. Sub-frame crossmembers are installed every 16". The channel is 1-1/2" wide x 3" high x 3/16" thick. The body crossmembers shall extend the full width to support the compartment framing and shall be welded to the sub-frame main members.

The Body sub-frame main members consist of 6061-T6 Aluminum square tubing of 2" wide x 6" high x 3/16" thick.

The perimeter shall be made with 1/8" thick forged 3003H14 Aluminum. Forged aluminum brings a strong design that was specially made to embed emergency lighting & designed to fit properly a 4" reflective stripping.

The body shall be attached to the chassis rails with a minimum of four (4) heavy duty "U" bolts. The body shall be separated from the chassis by 3/8" Teflon. Attachment of the body and sub-frame will allow the body to resist from all distortion and off-road operational condition.

The body is a modular design to allow removal from the chassis for major repair or mounting on a new chassis. Isolating material between the body and the chassis to be installed

All welding shall be done electrically using 5356 aluminum welding wire.

Rear vertical skirt will be made from 1/8" 3003-H22 polished aluminum alloy treadplate.

Rear skirt to include Signal, brake, reverse lights, D.O.T., license plate & NFPA steps.

Clearance, marker, license plate lights and reflectors will be furnished and installed per D.O.T. Junction box supplied and installed under the flat bed.

License plate light shall be an Eon light with SS polish case that has a light output equivalent to a 10-watt halogen lamp. Eon light to have a 50,000 hrs. LED life.

LED Signal, brake and reverse lights will be High Quality Grote Automotive lights recessed mount into rear aluminum skirt area of body per FMVSS 108 and CMVSS 108 requirements. Light to be LED Oval with chromed housing.

Two (2) LED Amber marker/clearance lights with chrome housing and clear lens will be installed on the front side of the bed, one (1) each side. Two (2) LED Red marker/clearance lights with chrome housing and clear lens will be installed on the rear side of the bed, one (1) each side. Three (3) LED Red marker/clearance lights with chrome housing and clear lens will be installed at the rear center of the bed. Amber & Red reflectors shall be installed around the perimeter of the bed as per DOT requirement.

Two (2) heavy duty tow eyes shall be installed at the rear of the body (NFPA 1906 requirement). The tow eyes will be fastened directly to each rear chassis frame rail. Hardware shall have a clear and unobstructed access.

The rear of the flat bed shall have two (2) non-skid rear steps for access to pump and controls. The rear steps shall be made so it can be folded up for use in rough terrain. All steps shall sustain a minimum static load of 500 lbs. (227 kg) without deformation (NFPA 1906 & 1901 compliant).

An angle of approach and an angle of departure of at least 20 degrees shall be maintained at the front and the rear of the vehicle when it is loaded.

This will be no exception to the body specifications. Pre-built commercial flatbed bodies are not acceptable.

#### **Right side Integrated Pre-Connect Hose Tray**

Integrated on the right side of the flat bed body, one (1) enclosed pre-connected hose tray made from aluminum to hold a minimum of 150' of 1-3/4" hose.

Hose Tray to have a flip down door with latches. Tray design shall allow hoses to pay out in any direction and quick hose storage when finished.

Hose tray shall have a 1-1/2" Pre-Connect elbow.

The area shall be designed to prevent the accumulation of water and allow for ventilation to aid in drying hose in the storage area. Black Turtle Tiles to be installed and bolted on the floor.

#### **Left Side Integrated Pre-Connect Hose Tray**

Integrated on the left side of the flat bed body, one (1) enclosed pre-connected hose tray made from aluminum to hold a minimum of 150' of 1-3/4" hose.

Hose Tray to have a flip down door with latches. Tray design shall allow hoses to pay out in any direction and quick hose storage when finished.

Hose tray shall have a 1-1/2" Pre-Connect elbow.

The area shall be designed to prevent the accumulation of water and allow for ventilation to aid in drying hose in the storage area. Black Turtle Tiles to be installed and bolted on the floor.

#### **Compartments**

All compartments will be made with 1/8" tread plate aluminum sheet.

All compartments shall have a minimum of one (1) louvered panel bolted into a wall to provide the proper airflow inside the compartment.

All compartments shall be of sweep-out type with no lip at bottom edge for easy cleaning.

#### **Transverse Compartment**

One (1) transverse compartment of 13-1/2" long x 22" high x 94" wide shall be installed. Each side door shall be horizontally hinged, drop down style with retaining cables.

The overlap aluminum diamond plate compartment doors shall be securely attached to the body with a full stainless-steel hinge. Door openings shall be fitted with solid neoprene weather strip completely sealing the perimeter of the compartment door opening. The drop-down door shall be retained with cable. Compartment door seams is sealed with a pliable automotive body caulking. The compartment door is latched with recessed, polished stainless steel "D" ring handles and locks.

#### **Top Transverse Storage Hose Tray**

One (1) aluminum storage hose tray shall be supplied and installed on top of the transverse compartment.

The dimensions of the storage tray shall be full length of the top compartment, 94" L x 9-3/8" W x 8" H.

The area shall be designed to prevent the accumulation of water and allow for ventilation to aid in drying hose in the storage area. Black Turtle Tiles to be installed and bolted on the floor. The storage tray shall be covered with black canvas and rear net.

#### **Left (Driver) Side Compartment**

One (1) 62" long x 30" high x 22" deep compartment behind the chassis, located at the left (driver) side of the water tank.

The overlap aluminum compartment doors shall be securely attached to the body with a full stainless-steel hinge. Door openings shall be fitted with solid neoprene weather strip completely sealing the perimeter of the compartment door opening. Lift up doors shall be installed with gas hold open struts. The 1/8" compartment doors are latched with recessed, polished stainless steel "D" ring handles and locks.

The aluminum doors complete with the following features: door ajar switch and two (2) LED strip lights.

One (1) switch shall be installed so the compartment light(s) shall come on only when compartment door is open.

There shall be a set of tracks for future installation of adjustable shelf(s) in each compartment. These tracks shall be installed vertically on the walls of the compartment(s) and shall offer a multitude of height adjustment possibilities.

The compartment floor will be covered with Plastic Tiles. The tiles shall be black with yellow angled leading edges.

#### **Right (Passenger) Side Compartment**

One (1) 62" long x 30" high x 22" deep compartment behind the chassis, located at the left (driver) side of the water tank.

The overlap aluminum compartment doors shall be securely attached to the body with a full stainless-steel hinge. Door openings shall be fitted with solid neoprene weather strip completely sealing the perimeter of the compartment door opening. Lift up doors shall be installed with gas hold open struts. The 1/8" compartment doors are latched with recessed, polished stainless steel "D" ring handles and locks.

The aluminum doors complete with the following features: door ajar switch and two (2) LED strip lights.

One (1) switch shall be installed so the compartment light(s) shall come on only when compartment door is open.

There shall be a set of tracks for future installation of adjustable shelf(s) in each compartment. These tracks shall be installed vertically on the walls of the compartment(s) and shall offer a multitude of height adjustment possibilities

The compartment floor will be covered with Plastic Tiles. The tiles shall be black with yellow angled leading edges.

#### **Rear Storage Compartment**

One (1) integrated to the platform compartment approximately 5" high x 24" wide x 104" long for suction hose storage and folding ladders or pike poles. A flip down horizontally hinges door is furnished at the rear. The interior compartment is made from polished 3003-H14 alloy smooth plate.

#### **Wheel Chocks**

Medium Kocheck Wheel Chocks with storage brackets shall be provided and mounted underneath the flatbed behind the chassis cab.

**Rear Mud Flaps**

Rear rubber mud flaps are provided. A bracket attached to the side of the muffler pipe end is installed to prevent any damaged that can occur to the mud flap.

**Electrical Components**

A 12-volt electrical system is supply.

The wiring is secured in place, readily accessible and protected against heat, water and physical damage.

Electrical harness lines shall be mechanically attached to the frame or body structure of the apparatus.

All wiring will be run in heat and moisture resistant plastic convoluted split loom.

Electrical harness lines shall be furnished with protective looms, grommets, or other devices at each point where they pass through body panels or structural members or wherever they lie against a sharp metal edge. A through-the-frame connector shall be permitted to be used in place of metal protective looms or grommets.

Switches, relays, terminals, and connectors shall have a direct current (dc) rating of 125 percent of maximum current for which the circuit is protected.

Conductor insulation will conform to S.A.E. requirements. All circuit are protected by automatic reset circuit breakers.

All wiring furnished will conform to the national Electric Code.

All circuits will be wired in conformance with S.A.E. J1292, Automobile wiring standard.

All wiring will be function worded schematically.

An electric diagram will be remit upon delivery.

**Console**

One CET fire application custom console installed between seats with rocker switch. To be quickly identified and visible to the driver and passenger while seated, the rocker switches shall be installed on the top face of the console designed with a 40° angle. This area shall be able to hold at least two rows of rocker switch. All switches shall be appropriately identified by panel mounted legends.

The first lighted rocker switch shall be a red Master Optical Warning switch. A master body disconnect automatic switch, normally open contacts, shall be provided to disconnect all electrical loads not provided by the chassis manufacturer. The starter solenoids shall be connected directly to the batteries.

All rocker switches to have a green "On" indicator that is visible from the driver's position shall be provided.

The console has an area to accommodate department map books, clipboards etc.

The console has an area for one (1) radio heads & Siren installation.

All electrical components like breaker, relays, wiring etc. will be installed inside this customized console and protected with an aluminium box. This console will be design to easily gain access to those breakers, relays, wiring, etc.

Controls and switches that are expected to be operated by the driver while the apparatus is in motion shall be within convenient reach for the driver.

Console shall be painted black scratch free Herculiner finish.

### **Emergency Lighting**

One (1) 56" LED Whelen Justice Lightbar, model #JE2NFPA shall be mounted on the headrache rack and controlled by one (1) switch on the cab console.

- 4 x Red SUPER LED Corners
- 4 x Red SUPER LED Inner
- 2 x White SUPER LED Inner

For Blocking Right-of-Way Mode of operation, white Super LED Inner lights (2) shall be turned off when the transmission is on Park position.

Mounted on front chassis grill, Two (2) Whelen Ion-T series Super LED, one (1) each side, red with clear lens with a chrome flange.

Mounted on sides of the chassis, Two (2) Whelen Ion-T series Super LED, one (1) each side, red with clear lens with a chrome flange.

Mounted on sides of the flatbed, Two (2) Whelen M4 series Linear Super LED, one (1) each side, red with clear lens with a chrome flange.

Mounted in the rear of the flatbed, Two (2) Whelen M4 series Linear Super LED, one (1) each side, red with clear lens with a chrome flange.

All emergency lights shall be connected and controlled by one (1) switch on the cab console.

### **Siren & Speaker**

One (1) Whelen, model #295SLSA1, 100-watt electronic siren amplifier with PA and switch control center to be provided and installed. Siren shall have wail, hyper-yelp and air horn tones as well as public address and shall be capable of radio rebroadcast.

One (1) Whelen, model #SA315P, 100-watt speaker, shall be provided and mounted on the front bumper with a mounting bracket.

### **Two (2) Telescopic Scene Lights FCA512-D30-ON**

Two (2) 300W telescoping 12v scene lights mounted at the front of the flatbed. The light shall be single head design. One light mounted on each side will increase visibility around the apparatus during night or light operations. Model is to be Fire Research FCA512-D30-ON. A switchbox is provided underneath each lamp head.

**Battery Charger**

One (1) Auto Charger Kit, single battery system, 18 amps, 12 volts shall be provided and installed in the chassis cab on the floor, under the rear seat on the driver side.

The Auto Charge kits include the Automatic battery charger, circuit breaker & ground fault protected outlet to power accessories on the vehicle and Super Auto Eject with water proof cover. Brand shall be Kussmaul, Auto Charge 1000 model.

**Compartment Lights Switches**

One (1) switch per compartment shall be installed so the compartment light(s) shall come on only when compartment door is open.

**Door Ajar**

One (1) door ajar warning light shall be provided and installed in the console to indicate an open body compartment door. The light shall be properly marked with a sign "Warning Door Ajar".

**Back-Up Alarm**

One (1) back-up alarm that meets the type D (87 dBA) requirements of SAEJ994 shall be provided at the rear of the apparatus. It will activate when the transmission is placed in reverse.



## **CET Fire Pumps Mfg Drop-In-Unit**

### **Tank**

The water tank shall be constructed of 1/2" thick polypropylene sheet. The material shall be of a certified, high quality, non-corrosive, stress relieved thermos plastic, black in colour with a textured finish, and UV stabilized for maximum protection. The skid type booster tank shall be of a standard configuration and shall be so designed to have complete modular slide in capability. All joints and seams are to be fully welded and electronically tested for maximum strength. The unit shall incorporate transverse partitions manufactured for 1/2" polypropylene which shall interlock with a series of longitudinal partitions constructed of 1/2" polypropylene. All swash partitions shall be so designed to allow for maximum water and air flow between compartments and are fully welded to each other as well as to the inside of the tank.

The passenger side rear wall of the tank shall have a standard built in sight gauge 2" in width, and 70% transparent.

Tank will be baffles in accordance with NFPA bulletin 1906 requirements, latest version.

### **Fill tower and tank cover**

The tank shall be equipped with a combination vent/overflow and manual fill tower. The fill tower shall be an 8" round by 6" high with a moulded drop-on type cover. The cover shall be attached to the tower with a rope to prevent loss. The tower shall be located in the right rear corner of the tank. There shall be a vent / overflow installed inside and to the extreme rear of the tower approximately 2" down from the top. This vent / overflow shall be of a standard schedule 40 polypropylene pipe with minimum ID of 3". The vent / overflow shall be piped internally and exit out at the passenger side tank wall with a 1" extension past the wall.

The tank cover shall be constructed of 1/2" thick polypropylene, black in color, UV stabilized.

### **Tank Capacity**

The tank shall have a capacity of 300 U.S. gallons of water. The tank shall be covered by the *ALL-OUT* No-Fault Life Time Warranty.

### **Sump**

The floor of the tank shall be manufactured from 3/4" polypropylene. There shall be one (1) sump as standard per tank. The sump shall be integral to the tank floor and be a minimum of 1/2" deep recessed into the floor. The sump shall not be visible from or protrude through the bottom of the tank.

### **Tank Outlets**

There shall be two standard tank outlets located in the same vertical plane on the driver side rear wall of the tank. One (1) 2-1/2" female NPT tank to pump suction fitting and one (1) 1-1/2" female NPT tank fill fitting with flow deflector

### **1" Tank Drain**

There shall be a 1" tank drain to the rear right side of the tank with a plug.

**Tank Mounting Blocks**

The cover shall incorporate two (2) booster reel mounting blocks that shall be to accommodate two (2) each sliding nut fasteners. These mounting blocks shall be welded to the covers running from the rear edge of the tank forward.

**Skid Base**

There shall be a full width skid base manufactured of 3/4" polypropylene welded to the tank. This base shall be 48" wide by 96" long and shall extend 34" past the tank in the rear to allow for pump mounting. The pump mounting area shall be supported by 1/2" polypropylene gussets 15" high by 32" long. The gussets shall be equipped with 2" holes to assist in lifting the unit.

**Mounting**

The Drop-In-Unit shall be mounted in a manner that allows access to the engine, pump, and auxiliary systems for routine maintenance. The Drop-In-Unit shall not be welded or otherwise permanently secured to other components.

The mounts shall allow for the truck to be secured directly to a truck bed without the need for any skid frame work underneath.

**CET Fire Pump, PFP-21hp-DSL-MR**

The pump shall be a CET PFP-21hp-MR single stage centrifugal pump, bolted directly to the engine, with a 2.5" victaulic suction inlet, and a 1.5" flange discharge outlet.

The volute and pump head shall be a lightweight, high strength, seawater resistant, aluminum alloy. The impeller shall be a bronze enclosed type for maximum efficiency, fully machined and balance. The shaft seal shall be self-adjusting, self-lubricating, and mechanical type.

The pump piping shall be flexible to prevent any breakage caused by vibration.

The pump shall be capable of a maximum discharge volume of 275 GPM at 10 PSI, and a maximum discharge pressure of 175 PSI while pumping 60 GPM. In the center of the performance curve, the pump shall be capable of pumping 250 GPM at 50 PSI and 95 GPM at 150 PSI. Pump to be mounted at rear.

The performances are based on a maximum altitude of 500ft and any higher elevation will lower the pump performance. The standard engine performance drops are 3% for every 1000 feet.

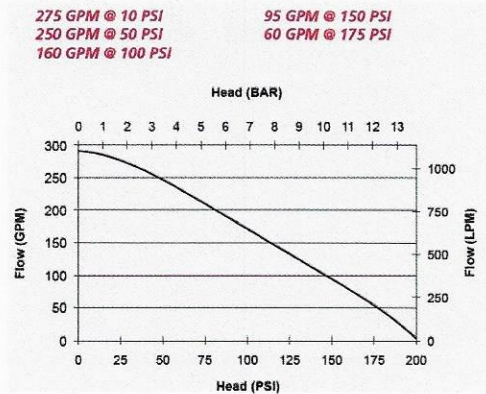

**Engine**

The pump shall be driven by a 3-cylinder, DIESEL engine powered, Kubota 21 horsepower engine. The engine shall be water cooled, with a 12-volt electric start.

The engine shall be connected to the battery of the chassis and shall be connected to the fuel tank of the chassis with a low-pressure, 2-4 psi, 12 VDC fuel pump connected to the ignition of the pump engine.

**Deluxe Pump Control panel**

A Deluxe Control Panel shall be supplied and installed on the pump. The Control Panel shall be manufactured from aluminum and completely covered with a black plastic plate. The Control Panel shall consist of a unkeyed start switch, engine stop, oil pressure, glow plug and engine temperature warning lights, 2.5" diameter pump discharge and pump intake liquid filled pressure gauges, primer control, throttle lever and illumination for controls with the installation of one new design tube light. All pump controls and gauges shall be properly marked with white letters engrave in the black plastic plate.

**Exhaust Primer**

The pump engine shall be equipped with a quieter exhaust venturi type primer capable of 15' – 20' lift for fast positive priming. The control for the primer shall be capable of being operated by a person operating controls at the primary pump operator's position.

**Plumbing and Valves**

Intake and discharge piping shall not interfere with the routine maintenance of the pump, engine, or auxiliary systems and shall not unduly restrict the servicing of these components.

**Steel Suction Piping - 2.5" - Two (2) Fire Type Swing-Out Valves**

All piping on the suction side shall be made of steel (welded joints) painted red. The suction piping, the pump and the discharge shall be tested to 400 PSI.

The suction piping shall consist of a 2.5" tank to pump line with a 2.5" flexible rubber hump hose to minimize flex and vibration between the pump and the tank.

RIGID PIPING SHALL NOT BE ACCEPTABLE.

Between the tank and the pump there shall be a 2.5" fire type swing-out valve. This valve shall remain open to pump from the tank.

This pipe shall have a tee into the suction side of the pump and shall continue to the rear of the truck for overboard suction where there shall be an additional 2.5" fire type swing-out valve.

The overboard suction connection shall have a 2.5" NST female swivel adapter and a 2.5" NST plug with retaining cable.

To draft, the tank to pump valve shall be closed, a suction hose connected to the overboard suction connection and placed in a static water supply, and the primer activated.

**Steel Discharge Piping**

All piping shall be steel piping or high-pressure flexible hose. A 2.5" X 2.5" square steel manifold shall be piped directly to the discharge outlet of the pump. Attached to this discharge manifold, by means of welded steel pipe nipples, shall be all the discharge valves. All piping shall be painted red to match the pump.

The discharge shall be equipped with a drain valve at the lowest point.

**1" Tank Fill**

There shall be a 1" valve piped from the discharge manifold as a means for refilling the tank. The valve shall be a fire type quarter turn swing-out valve handle and 1" NPT threads, and shall be connected to the tank fill port by 1" high pressure flexible hose.

**One (1) 1" Discharge to Rear**

There shall be one (1) 1" valve piped from the discharge manifold to the rear of the truck for connection of forestry hose. The valve shall be a fire type quarter turn swing-out valve with 1" NST threads. The valve shall be furnished with a garden hose (GHT) cap and chain.

**One (1) 1.5" Discharge to Rear**

There shall be one (1) 1.5" valve piped from the discharge manifold to the rear of the truck for connection of forestry hose. The valve shall be a fire type quarter turn swing-out valve with 1.5" NST threads. The valve shall be furnished with a 1.5" NST cap and chain.

**One (1) 1" Discharge to Booster Reel**

There shall be 1" valve piped from the discharge manifold to the booster reel. The valve shall be a fire type quarter turn swing-out valve handle and 1" NPT threads and shall be connected to the reel by 1" high pressure flexible hose.

**One (1) Booster Hose Reel**

One (1) 12v electric rewind booster hose reel capable of handling 200' of 1" diameter booster hose. The reel shall have a push button rewind control and a backup geared crank rewind handle. The reel shall be equipped with a 1" NPT 90° swivel inlet, and a 1" NST outlet riser. The reel shall be manufactured of steel and shall be primed and painted red. The reel shall be installed on the rear right corner of the flatbed, facing rear.

One (1) high mounted roller and spool assembly shall be furnished and installed on the reel.

200' of 1" rubber booster hose shall be supplied and installed on the reel.

**Two (2) 1.5" Discharges to Pre-Connected Hose Trays**

Two (2) 1.5" valves piped from the discharge manifold to each pre-connected integrated hose tray. The valves shall be fire type quarter turn swing-out valves with handles and connected to each pre-connected hose tray by 1.5" high-pressure flexible plumbing.

**Testing**

The pump shall be tested after the pump and all its associated piping and equipment have been installed on the fire apparatus. The tests shall be conducted at the manufacturer's approved facility. The testing shall include at least the pumping tests, the priming device test, the vacuum test. The water tank-to-pump flow test, and the piping integrity test.

**General Warranty**

CET warrants to the original purchaser that CET will, at its election, either replace or repair any part of the new equipment sold to the purchaser hereunder which has been given no abnormal use; and which has received proper maintenance; and which is determined by CET to be defective in material or workmanship; and which has, within one (1) year after delivery to the purchaser be returned at the purchaser's expense, with transportation charges prepaid, to CET factory OR which has, within one (1) year after delivery to the purchaser, been pre-approved by CET for a third-party to perform the work. All problems shall be reported to CET in writing and damaged parts shall be returned to CET.

**CET Fire Pump Warranty**

CET warrants to the original purchaser that CET will, at its election, either replace or repair any part of the Pump sold to the purchaser hereunder which has been given no abnormal use; and which has received proper maintenance; and which is determined by CET to be defective in material or workmanship; and which has, within three (3) years after delivery to the purchaser be returned at the purchaser's expense, with transportation charges prepaid, to CET factory OR which has, within three (3) years after delivery to the purchaser, been pre-approved by CET for a third-party to perform the work. All problems shall be reported to CET in writing and damaged parts shall be returned to CET.

**Exclusions from warranty:**

1. CET incurs no liability under this warranty or otherwise for parts, accessories or components not manufactured by it, but purchased for assembly into the equipment, but CET will assign to the Purchaser whatever warranty rights are extended by the supplier of such part, accessory or component
2. CET incurs no liability under this warranty or otherwise, for equipment which has been abused, altered or improperly maintained, or for equipment which has been returned for inspection or repair more than ten (10) days after defect complained of has been or should have been discovered by the Purchaser, or Equipment which is operated after the defect has been discovered.
3. CET incurs no liability for alteration or repairs unless the Purchaser first receives CET / written consent or approval. CET will not be responsible for work or repairs made or done by others.
4. CET incurs no liability for design alterations, parts, accessories or components which are not standard but are specified by the Purchaser for incorporation into the equipment.

**Interpretation**

CET shall not be liable for transportation charges either in shipment to or by it and shall not be liable for loss of use, or consequential damage of any kind in connection with the sales, alteration, repair or replacement of any equipment or part thereof. Liability under this warranty shall be limited to replacement or repair and in any event shall not exceed the purchase price paid. This warranty is not transferable by the Purchaser. CET reserves the right to make changes in design or add any improvements to the Equipment at any time without incurring any obligation to install or modify same on other equipment previously supplied.

There are no other warranties, conditions or representations, expressed or implied, except the above.

**CET Water Tank Warranty Limited Lifetime**

CET Fire Pumps, Mfg. warrants each CET water and/or foam tank to be free from manufacturing defects in material and workmanship for the service life of the original vehicle. Every CET tank shall be thoroughly inspected and tested for leaks before leaving our facility and must be installed in accordance with the CET Fire Pumps, Mfg. installation guidelines.

CET will repair or, at its option, replace the tank with a new tank. CET will cover customary and reasonable costs to remove and install the tank. This warranty will not cover the tanks that have been improperly installed, misused, or abused. The serial number must not have been altered, defaced or removed. CET will not cover any unauthorized third-party repairs or alterations. Any of these actions may void the warranty.

There are no warranties, expressed or implied, which extend beyond the description of the face, hereof. There is no express or implied warranty of merchantability or a warranty of fitness for a particular purpose. Additionally, this warranty is in lieu of all other obligations or liabilities on the part of CET Fire Pumps, Mfg.

This warranty contains the entire warranty. It is the sole warranty and price agreements or representation, whether oral or written, are either merged herein or expressly canceled. CET Fire Pumps, Mfg. neither authorizes any person supposing to act on its behalf to change, nor assume for it, any warranty or liability concerning its product.

In no event will CET Fire Pumps, Mfg. be liable for an amount in excess of the currently published retail price plus installation and removal cost of the tank, for any loss or damage, whether direct or indirect, incidental, consequential, or otherwise arising out of failure of its product.

This warranty gives you the specific legal rights, and you may also have other rights which vary from state to state. Some states do not allow exclusion or limitation of incidental or consequential damage, so the above limitation or exclusion may not apply to you. Since some states do not allow limitations on the length of an implied warranty, the above limitation may not apply to you.

The warranty is transferable within the United States and Canada at the discretion of CET Fire Pumps, Mfg. by notifying CET Fire Pumps, Mfg. within thirty (30) days of the vehicle transfer date. At that time, CET will, at its discretion, provide a transfer of ownership form.

**Manufacturer's discretion**

Materials, parts, or procedures used are subject to change at manufacturer's discretion at any time to provide equal or better products.



Certificate of Registration



This is to certify that the Quality Management System of:

**C.E.T. Fire Pumps MFG Limited**

75 rue Hector  
Pierreville QC J0G 1J0  
Canada

applicable to:

**Design and manufacture of fire equipment.**

has been assessed and approved by  
National Quality Assurance, U.S.A., against the provisions of:

**ISO 9001:2015**

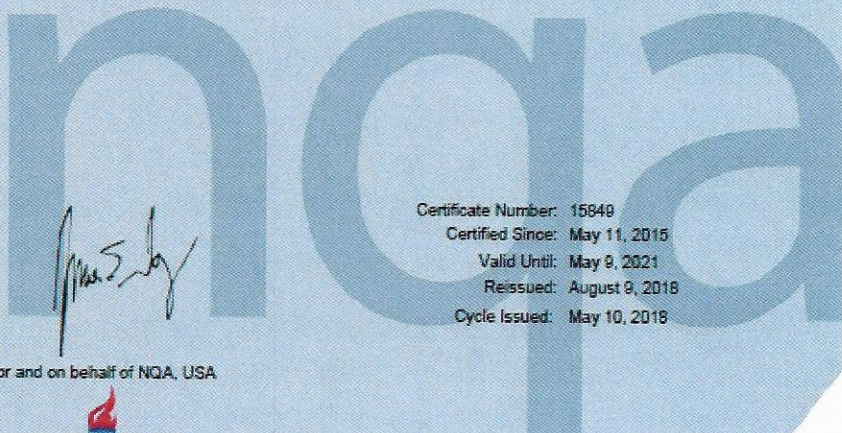

*[Signature]*

Certificate Number: 15849  
 Certified Since: May 11, 2015  
 Valid Until: May 9, 2021  
 Reissued: August 9, 2018  
 Cycle Issued: May 10, 2018

For and on behalf of NQA, USA

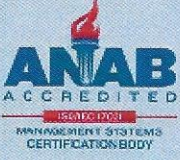

This approval is subject to the company maintaining its system to the required standard, which will be monitored by NQA, USA, 289 Great Road, Suite 105, Acton, MA 01720, an accredited organization under the ANSI-ASQ National Accreditation Board.

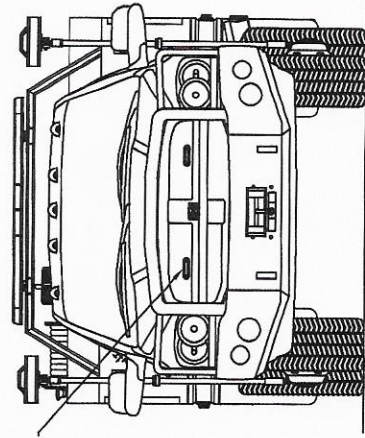

(2) WHELEN SUPER LED ION-T SERIES EMERGENCY LIGHTING

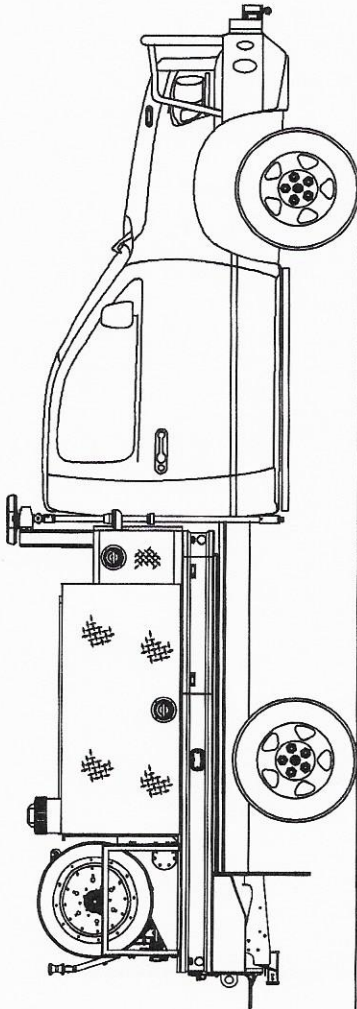

RANCH HAND BUMPER W/ WINCH M12

(2) WHELEN SUPER LED ION-T SERIES EMERGENCY LIGHTING

FLATBED UNIT SEE DRAWING: FA-1648-0701

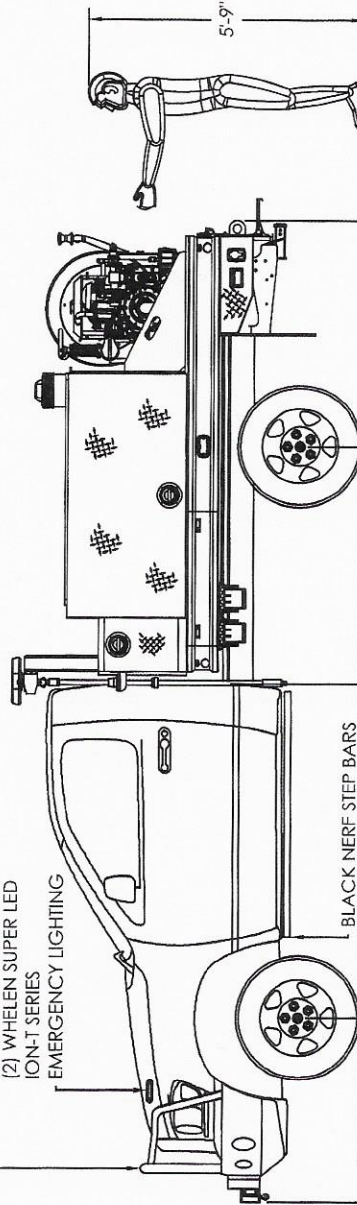

BLACK NERF STEP BARS

W.B. 143<sup>3</sup>/<sub>16</sub>

60 C.A.

246<sup>1</sup>/<sub>16</sub> APPROX.

5'-9"

87<sup>1</sup>/<sub>2</sub> APPROX.

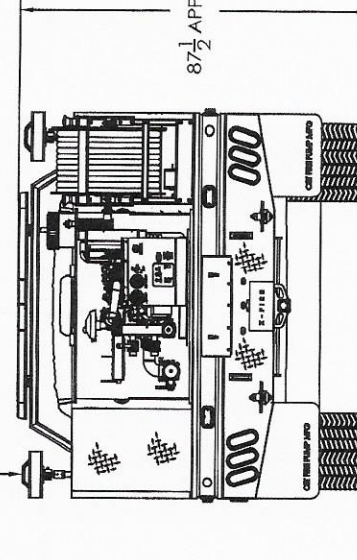

TITLE:

BRUSH TRUCK - LEEDS FD. AL

W/ DODGE 3500 DIESEL, 2020, REGULAR CAB, 4x4

**WARNING**

THIS DOCUMENT REMAINS THE PROPERTY OF C.E.T. FIRE PUMPS MFG. ALL REPRODUCTION WITHOUT WRITTEN AGREEMENT FROM C.E.T. FIRE PUMPS MFG IS TOTALLY PROHIBITED.

CREATED BY: C.B. DATE: 2019-12-17

No:

PRODUCTION #: N/A

FA-1648

PAGE: 1 of 1

VERIFIED BY: A.B. DATE: 2019-12-17



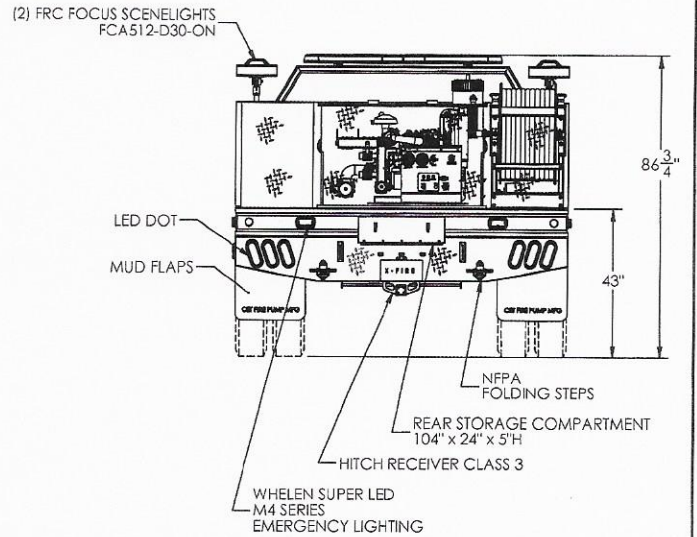
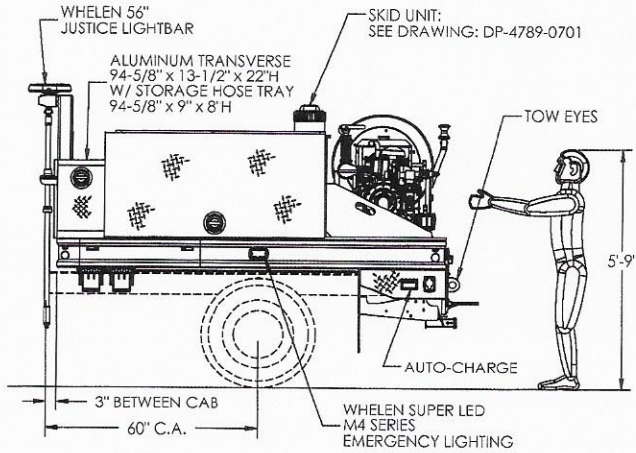
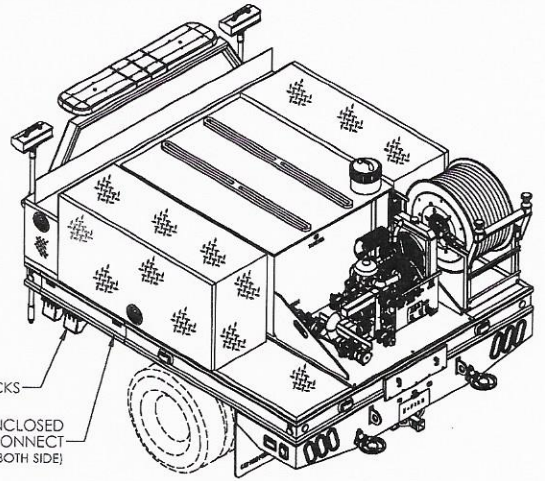
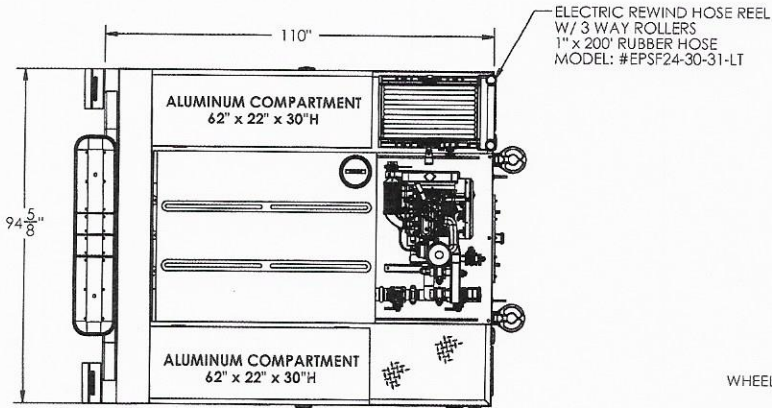

<b>CREATED</b>	<b>TITLE :</b>	<b>LEEDS FD</b>	<b>WARNING</b>  THIS DOCUMENT REMAINS THE PROPERTY OF C.E.T. FIRE PUMPS MFG.  ALL REPRODUCTION WITHOUT WRITTEN AGREEMENT FROM C.E.T. FIRE PUMPS MFG IS TOTALLY PROHIBITED.
<b>BY:</b> C.B.		<b>:- GLIDER KIT</b>	
<b>DATE:</b> 2019-12-17			
<b>VERIFIED</b>	<b>No:</b>	<b>FA-1648-0701</b>	
<b>BY:</b> M.V.			
<b>DATE:</b> 2019-12-17			

\*DRAWING MAY DIFFER FROM REALITY

DP-4789-0701

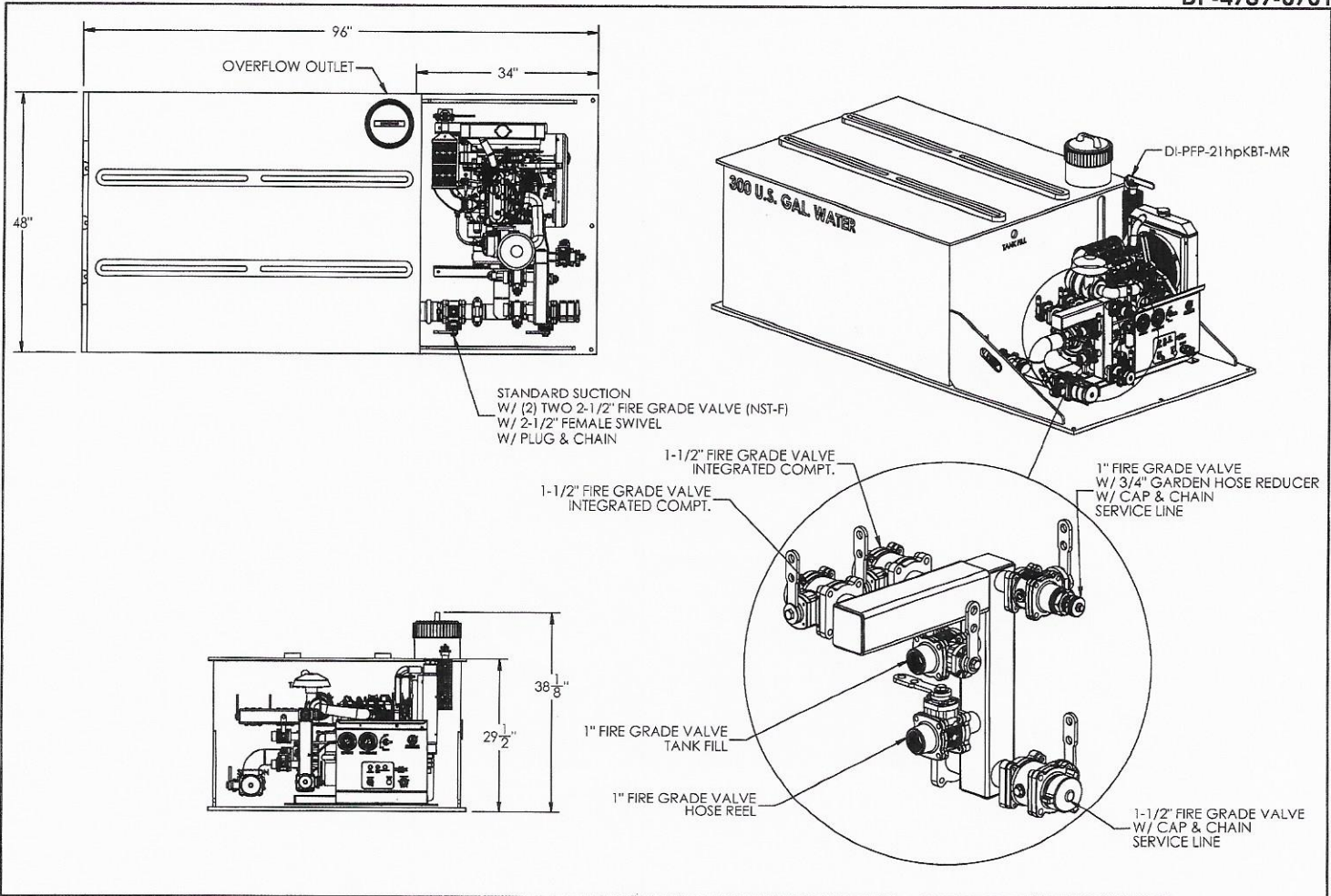

<b>CREATED</b>	<b>TITLE :</b> LEEDS FD		<b>QUOTE #</b>	<b>WARNING</b>
BY: C.B.	300 U.S. GAL WATER		16660	THIS DOCUMENT REMAINS THE PROPERTY OF C.E.T. FIRE PUMPS MFG. ALL REPRODUCTION WITHOUT WRITTEN AGREEMENT FROM C.E.T. FIRE PUMPS MFG IS TOTALLY PROHIBITED.
DATE: 2019-12-16	- U.S. GAL. F.C.			
<b>VERIFIED</b>	<b>No:</b> DP-4789-0701	<b>DEFENDER</b> S	<b>OPP #</b> 13362	
BY: M.V.		<b>APPROXIMATE WET WEIGHT</b>	<b>APPROXIMATE DRY WEIGHT</b>	
DATE: 2019-12-16		- Lbs	- Lbs	

APPROVED BY \_\_\_\_\_

APPROVED DATE \_\_\_\_\_

\*DRAWING MAY DIFFER FROM REALITY.



**NAFECO** <sup>TM</sup>  
*Your No Excuse Company*

**1-800-628-6233**

**24 Hour Fax: (256) 355-0852**

Thank you for the opportunity to submit a proposal on your new apparatus purchase.

As part of our commitment to the fire service, we have an ongoing quality assurance program to ensure our apparatus give you good service for many, many years. This program involves continuous evaluation and testing of materials and designs plus analyzing and evaluating comments we receive from the end users.

NAFECO, in Decatur AL, is the nearest parts and service center to your location. NAFECO is set up to handle most of your warranty claims at the end user's facilities. With, three (3) mobile service units, EVT Certified Mechanics, and a 24 hour emergency line, we strive to give all users the best service in the Industry.

Customers in need of warranty claims, service, or repair may contact Brandon Oaks, Service Manager at (256) 353-7100 ext. 150 Monday-Friday 8 a.m.-5 p.m. or (800) 628-6233 (after hours). Customers in need of replacement parts may contact our dedicated parts department.

Description of vehicles, mechanics, and facilities:

1. We have three mobile service vehicles. Each vehicle is less than three years old. Each mobile unit carries parts and equipment for most standard repair operations. This includes wiring and accessories most commonly used lights, fasteners, diagnostic equipment, valve repair kits, pump parts, mounting equipment and accessories, routine maintenance items, and much more.
2. Each of our mechanics is EVT certified, KME and have certifications for major components on the apparatus such as the pump. Each of our mechanics has over five years experience repairing fire apparatus, with our most experienced mechanic having over ten years experience.
3. Our service center is located in Decatur, Alabama. The service center has three dedicated truck bays with other bays available in case of high volumes. Each bay is heated, fully protected from the weather, and is secured during off hours. We stock a large volume of parts and accessories for apparatus. Most standard items can be delivered from our Decatur office with less common items being shipped from the factory.



Additional service/parts/warranty providers (and their authorized dealerships/service centers/mobile service) may include, but are not limited to the following:

**NORTH AMERICA FIRE EQUIPMENT CO., INC.**

**1515 West Moulton St. • Decatur, AL 35601 • (256) 353-7100 • Fax (256) 353-3215 • [www.nafeco.com](http://www.nafeco.com)**



**NAFECO** <sup>TM</sup>

*Your No Excuse Company*

**1-800-628-6233**

*24 Hour Fax: (256) 355-0852*

Cummins Engines  
Allison Transmissions  
Meritor axles  
UPF Poly Tanks

Unless otherwise requested by the fire department, warranty and service for engines, transmissions, etc. shall be provided at the service location closest to the fire department in order to reduce the amount of time the truck is out of service or away from the fire department.

**NORTH AMERICA FIRE EQUIPMENT CO., INC.**

**1515 West Moulton St. • Decatur, AL 35601 • (256) 353-7100 • Fax (256) 353-3215 • [www.nafeco.com](http://www.nafeco.com)**

**Item Attachment Documents:**

24. Consider 2020-01-03 Consider Budget Adjustment - Leeds Tree Commission

# CITY OF LEEDS

## RESOLUTION NO.: 2020-01-03

### RESOLUTION APPROVING AND AUTHORIZING A BUDGET ADJUSTMENT AND RELATED APPROPRIATIONS REGARDING THE CITY TREE COMMISSION

**WHEREAS**, certain payments made for the purposes of upkeep and maintenance in the downtown area were erroneously made from the City Tree Commission fund instead of the appropriate City Downtown Beautification fund; and

**WHEREAS**, the aforementioned payments were made in error and due to be refunded to the City Tree Commission fund; and

**WHEREAS**, in order for these erroneous payments to be properly credited, the City Council should authorize the subject budget adjustments which would result in the appropriate reduction in the City Beautification fund balance.

**NOW THEREFORE, BE IT RESOLVED**, by the City Council of the City of Leeds that:

1. The Recitals above are true, correct, and included herein as if fully set forth.
2. The Tree Commission line item within the City budget (4000-44160) shall be credited with the appropriate amount (e.g.\$6078.00) and the proper adjustment shall be made to the City Beautification fund.
3. The Mayor and staff shall have the full authority to do those things, perform those functions, make such decisions, and to sign necessary documentation in order to carry out and fully complete the actions so authorized herein.

**ADOPTED and APPROVED** this the 6<sup>th</sup> day of January 2020.

CITY OF LEEDS, ALABAMA:

\_\_\_\_\_  
David Miller, Mayor

\_\_\_\_\_  
Date

ATTEST:

\_\_\_\_\_  
Toushi Arbitelle, City Clerk

<b>AYES:</b>	_____
<b>NAYS:</b>	_____
<b>ABSENT FROM VOTING:</b>	_____
<b>ABSTAIN:</b>	_____

I, Toushi Arbitelle, City Clerk of the City of Leeds, hereby certify that the above Resolution was duly adopted by the City Council of the City of Leeds at a regular meeting held on the 6<sup>th</sup> day of January 2020.

\_\_\_\_\_  
City Clerk

215

18-2019

City of Leeds  
VENDOR ACTIVITY REPORT  
BOTH OPEN & PAID VOUCHERS

CHECK DATES 10/01/2017 TO 09/30/2019 PAY DATES 10/01/2017 TO 09/30/2019

VENDORS 3024 TO 3024

PURCHASE ORDERS 0 TO 2147483647

VOUCHERS WITH OUTSTANDING CHECKS ONLY

VOUCHER NUMBER	PAY/CHECK DATE	INVOICE NUMBER	INVOICE DATE	PO NUMBER	CHECK NUMBER	INVOICE AMOUNT
3024 GREEN UP GARDEN SHOP						
58463	06/15/2018	137	05/31/2018	12829	43295	2,128.00
		PLANTS / SOIL / LABOR				
		100-4000-44160-000 TREE COMMISSION				2,128.00
58464	06/15/2018	136	06/05/2018	12828	43295	3,950.00
		PLANTS / SOIL / LABOR				
		100-4000-44160-000 TREE COMMISSION				3,950.00
						6,078.00
TOTAL VOUCHERS:						6,078.00
TOTAL OPEN VOUCHERS:						0.00
TOTAL PAID VOUCHERS:						6,078.00

216

Vendor: 3024 06/15/2018  
 GREEN UP GARDEN SHOP

043295  
 43295

Invoice Number	Invoice Date	PO Number	Description	Invoice Amount
137	05/31/2018	12829	PLANTS / SOIL / LABOR	2,128.00
136	06/05/2018	12828	PLANTS / SOIL / LABOR	3,950.00

6,078.00

ORIGINAL CHECK IS PRINTED ON CHEMICAL REACTIVE PAPER AND HAS MICRO PRINTING IN THE SIGNATURE LINE

**CITY OF LEEDS**  
 1040 PARK DRIVE  
 LEEDS, AL 35094  
 205-699-2585

COVENANT BANK  
 HOME OFFICE  
 LEEDS, AL 35094  
 61-627/622

043295  
 43295

PAY

SIX THOUSAND SEVENTY-EIGHT AND XX / 100

DATE

AMOUNT

06/15/2018

\*\*\*\*\*6,078.00

VOID AFTER 90 DAYS  
 CITY OF LEEDS

TO THE  
 ORDER  
 OF

GREEN UP GARDEN SHOP  
 1536 SIMS STREET  
 LEEDS, AL 35094

*[Signature]*  
 [Signature]

⑈043295⑈ ⑆062206279⑆ 50009042⑈

043295

Vendor:	Invoice Number	Invoice Date	PO Number	Description	Invoice Amount
3024	137	05/31/2018	12829	GREEN UP GARDEN SHOP PLANTS / SOIL / LABOR	2,128.00
	136	06/05/2018	12828	PLANTS / SOIL / LABOR	3,950.00

06/15/2018 43295

CHECK AMOUNT: 6,078.00



217



# INVOICE

**Green Up Garden Shop**  
1536 Sims Street  
Leeds, AL 35094  
United States  
  
205-542-5801

**BILL TO**  
**City of Leeds**  
Jennifer Packer  
8373 1st. Ave.  
Leeds, 35094  
  
205-699-0907  
jpacker@leedsalabama.gov

**Invoice Number:** 137  
**Invoice Date:** June 5, 2018  
**Payment Due:** June 5, 2018  
**Amount Due (USD):** \$2,128.00

Items	Quantity	Price	Amount
<b>Hanging Baskets Downtown</b> Plants, soil, labor, etc.	1	\$2,128.00	\$2,128.00

**Total:** \$2,128.00

**Amount Due (USD) :** \$2,128.00

Purchase Req # 12957  
has been successfully  
Reviewed  
06/11/18

Fund	Department	Function	Modifier
RO	Purchase Order	Pay Group	Check Sort
Clerk			Finance

218



# INVOICE

**Green Up Garden Shop**  
1536 Sims Street  
Leeds, AL 35094  
United States  
205-542-5801

**BILL TO**  
**City of Leeds**  
Jennifer Packer  
8373 1st. Ave.  
Leeds, 35094  
  
205-699-0907  
Jpacker@leedsalabama.gov

**Invoice Number:** 136  
**Invoice Date:** June 5, 2018  
**Payment Due:** June 5, 2018  
**Amount Due (USD):** \$3,950.00

Items	Quantity	Price	Amount
<b>Spring Annuals 2018</b> Plants, Fertilizer, Labor...	1	\$3,950.00	\$3,950.00

**Total:** \$3,950.00

**Amount Due (USD) :** \$3,950.00

Purchase Req # 12956  
has been successfully  
Reviewed.  
06/12/18

Fund	Department	Function	Modifier
RO	Purchase Order	Pay Group	Check Sort
Clerk		Finance	

*12828* *05*  
*[Signature]* *[Signature]*

**Item Attachment Documents:**

25. Consider 2020-01-04 Consider Adoption and Ratification of Monthly City Expenditures/Payables

# CITY OF LEEDS

## RESOLUTION NO.: 2020-01-04

### RESOLUTION IN ADOPTION AND RATIFICATION OF MONTHLY CITY PAYABLES/EXPENITURES

**WHEREAS**, although the Council approves a City budget and the related expenditures on an annual basis, the Council also has made it a practice to review and to ratify those expenditures; and

**WHEREAS**, in order to improve accountability and transparency, the Finance Committee has recommended that the review and ratification procedure occur on a monthly basis; and

**WHEREAS**, the City staff and the City Council has considered the attached monthly City expenditures and considers the approval and/or the ratification of those items to be just, authorized, and in the best interest of the City.

**NOW THEREFORE, BE IT RESOLVED**, by the City Council of the City of Leeds that:

1. The Recitals above are true, correct and included herein as if fully set forth.
2. The attached list of City expenditures is hereby ratified and approved for the month ending December 31, 2019.
3. The Mayor and staff shall have the full authority to do those things, perform those functions, make such decisions, and to sign necessary documentation in order to carry out and fully complete the actions so authorized herein.

**ADOPTED and APPROVED** at a regular meeting of the City Council of the City of Leeds, Alabama on this the 6<sup>th</sup> day of January 2020

**CITY OF LEEDS, ALABAMA**

\_\_\_\_\_  
David Miller, Mayor

\_\_\_\_\_  
DATE

**ATTEST:**  
  
\_\_\_\_\_  
Toushi Arbitelle, City Clerk

<b>AYES:</b>	_____
<b>NAYS:</b>	_____
<b>ABSENT:</b>	_____
<b>ABSTAIN:</b>	_____

I, Toushi Arbitelle, City Clerk of the City of Leeds, hereby certify that the above Resolution was duly adopted by the City Council of the City of Leeds at a regular meeting held on the 6th day of January 2020

\_\_\_\_\_  
City Clerk

## City of Leeds - General Fund

## EXPENSE DETAIL

December 2019

DATE	TRANSACTION TYPE	NAME	MEMO/DESCRIPTION	SPLIT	AMOUNT	BALANCE
01-4000 Admin Exp						
12/15/2019	Bill	3119-CARD SERVICES (8365)	4304	00-2010 Accounts Payable	42.99	42.99
<b>Total for 01-4000 Admin Exp</b>					<b>\$42.99</b>	
01-4001 Salaries & Wages						
Beginning Balance						34,070.88
12/06/2019	Expense	PAYROLL & BENEFIT SOLUTIONS LLC (PBS)		00-1122 General Fund Checking Accounts:Payroll Acct-Servis 1st-1427	11,040.15	45,111.03
12/20/2019	Expense	PAYROLL & BENEFIT SOLUTIONS LLC (PBS)		00-1122 General Fund Checking Accounts:Payroll Acct-Servis 1st-1427	10,577.48	55,688.51
<b>Total for 01-4001 Salaries &amp; Wages</b>					<b>\$21,617.63</b>	
01-4002 Payroll Taxes						
Beginning Balance						2,460.01
12/06/2019	Expense	PAYROLL & BENEFIT SOLUTIONS LLC (PBS)		00-1122 General Fund Checking Accounts:Payroll Acct-Servis 1st-1427	805.73	3,265.74
12/20/2019	Expense	PAYROLL & BENEFIT SOLUTIONS LLC (PBS)		00-1122 General Fund Checking Accounts:Payroll Acct-Servis 1st-1427	769.92	4,035.66
<b>Total for 01-4002 Payroll Taxes</b>					<b>\$1,575.65</b>	
01-4004 Health Insurance						
Beginning Balance						2,748.00
12/06/2019	Expense	PAYROLL & BENEFIT SOLUTIONS LLC (PBS)		00-1122 General Fund Checking Accounts:Payroll Acct-Servis 1st-1427	-348.50	2,399.50
12/15/2019	Bill	2601-LOCAL GOVERNMENT HEALTH INSURANCE BOARD		00-2010 Accounts Payable	968.00	3,367.50
12/15/2019	Bill	2601-LOCAL GOVERNMENT HEALTH INSURANCE BOARD		00-2010 Accounts Payable	1,690.00	5,057.50
12/20/2019	Expense	PAYROLL & BENEFIT SOLUTIONS LLC (PBS)		00-1122 General Fund Checking Accounts:Payroll Acct-Servis 1st-1427	-348.50	4,709.00
<b>Total for 01-4004 Health Insurance</b>					<b>\$1,961.00</b>	
01-4005 Retiree Health Insurance Prem.						
Beginning Balance						10,630.00
12/15/2019	Bill	2601-LOCAL GOVERNMENT HEALTH INSURANCE BOARD		00-2010 Accounts Payable	4,393.00	15,023.00
<b>Total for 01-4005 Retiree Health Insurance Prem.</b>					<b>\$4,393.00</b>	
01-4006 Retirement						
Beginning Balance						4,082.73
12/06/2019	Expense	851- Retirement Systems of Alabama		00-1114 General Fund Checking Accounts:Gen'l Fund-Servis 1st-4304	1,017.22	5,099.95
12/19/2019	Expense	851- Retirement Systems of Alabama		00-1114 General Fund Checking Accounts:Gen'l Fund-Servis 1st-4304	1,008.62	6,108.57
<b>Total for 01-4006 Retirement</b>					<b>\$2,025.84</b>	
01-4015 EE Life & Disability Ins						
Beginning Balance						81.55
12/30/2019	Bill	2725b-MUTUAL OF OMAHA		00-2010 Accounts Payable	10.27	91.82
12/30/2019	Bill	2725b-MUTUAL OF OMAHA		00-2010 Accounts Payable	15.98	107.80
<b>Total for 01-4015 EE Life &amp; Disability Ins</b>					<b>\$26.25</b>	
01-4100 Insurance - General						
Beginning Balance						1,014.00
<b>Total for 01-4100 Insurance - General</b>						
01-4200 Electrical Utilities						
Beginning Balance						914.14
12/15/2019	Bill	3119-CARD SERVICES (8365)		00-2010 Accounts Payable	92.58	1,006.72
12/30/2019	Bill	111-ALABAMA POWER		00-2010 Accounts Payable	465.07	1,471.79
<b>Total for 01-4200 Electrical Utilities</b>					<b>\$557.65</b>	
01-4201 Internet						

DATE	TRANSACTION TYPE	NAME	MEMO/DESCRIPTION	SPLIT	AMOUNT	BALANCE
222						
		Beginning Balance				11,957.60
12/15/2019	Bill	3119-CARD SERVICES (8365)		00-2010 Accounts Payable	1,760.00	13,717.60
12/15/2019	Bill	2997-UNITI FIBER /dba/ CONTACT NETWORK/INLINE	CITY HALL; PD/COURTS; DEVELOPMENT SERVICES; FD	00-2010 Accounts Payable	4,218.80	17,936.40
<b>Total for 01-4201 Internet</b>					<b>\$5,978.80</b>	
		01-4202 Telephone Beginning Balance				317.09
12/15/2019	Bill	3119-CARD SERVICES (8365)		00-2010 Accounts Payable	307.24	624.33
<b>Total for 01-4202 Telephone</b>					<b>\$307.24</b>	
		01-4203 Cell / Wireless Services Beginning Balance				115.78
12/15/2019	Bill	3119-CARD SERVICES (8365)		00-2010 Accounts Payable	196.01	311.79
<b>Total for 01-4203 Cell / Wireless Services</b>					<b>\$196.01</b>	
		01-4204 Gas Utilities Beginning Balance				108.44
<b>Total for 01-4204 Gas Utilities</b>						
		01-4206 Water Utilities Beginning Balance				39.61
12/15/2019	Bill	3119-CARD SERVICES (8365)		00-2010 Accounts Payable	39.61	79.22
<b>Total for 01-4206 Water Utilities</b>					<b>\$39.61</b>	
		01-4208 Sewer Utilities Beginning Balance				43.19
12/15/2019	Bill	3119-CARD SERVICES (8365)		00-2010 Accounts Payable	44.19	87.38
<b>Total for 01-4208 Sewer Utilities</b>					<b>\$44.19</b>	
		01-4212 Storm Water Fee Beginning Balance				691.88
<b>Total for 01-4212 Storm Water Fee</b>						
		01-4300 Office Supplies				
12/15/2019	Bill	3119-CARD SERVICES (8365)		00-2010 Accounts Payable	9.44	9.44
<b>Total for 01-4300 Office Supplies</b>					<b>\$9.44</b>	
		01-4304 Copier & Printer Mtc Beginning Balance				183.16
<b>Total for 01-4304 Copier &amp; Printer Mtc</b>						
		01-4306 Department Supplies Beginning Balance				4,331.94
<b>Total for 01-4306 Department Supplies</b>						
		01-4308 PR Advertising Beginning Balance				118.80
<b>Total for 01-4308 PR Advertising</b>						
		01-4310 Legal Notices				
12/15/2019	Bill	3119-CARD SERVICES (8365)		00-2010 Accounts Payable	302.50	302.50
<b>Total for 01-4310 Legal Notices</b>					<b>\$302.50</b>	
		01-4314 Subscriptions Beginning Balance				12,155.81
12/15/2019	Bill	3119-CARD SERVICES (8365)		00-2010 Accounts Payable	1,410.87	13,566.68
<b>Total for 01-4314 Subscriptions</b>					<b>\$1,410.87</b>	
		01-4316 Dues & Fees Beginning Balance				1,822.00
12/06/2019	Expense	PAYROLL & BENEFIT SOLUTIONS LLC (PBS)		00-1122 General Fund Checking Accounts:Payroll Acct-Servis 1st-1427	308.00	2,130.00
12/15/2019	Bill	ALABAMA DEPT OF REVENUE	2020 CHEV TAHOE 1GNLCDEC1LR198318	00-2010 Accounts Payable	24.25	2,154.25
12/20/2019	Expense	PAYROLL & BENEFIT SOLUTIONS LLC (PBS)		00-1122 General Fund Checking Accounts:Payroll Acct-Servis 1st-1427	306.25	2,460.50
12/31/2019	Expense	PAYROLL & BENEFIT SOLUTIONS LLC (PBS)		00-1122 General Fund Checking Accounts:Payroll Acct-Servis 1st-1427	2,778.50	5,239.00
<b>Total for 01-4316 Dues &amp; Fees</b>					<b>\$3,417.00</b>	
		01-4320 Postage				

DATE	TRANSACTION TYPE	NAME	MEMO/DESCRIPTION	SPLIT	AMOUNT	BALANCE
223						
		Beginning Balance				280.50
12/15/2019	Bill	PURCHASE POWER		00-2010 Accounts Payable	1,024.00	1,304.50
12/15/2019	Bill	3119-CARD SERVICES (8365)		00-2010 Accounts Payable	172.45	1,476.95
<b>Total for 01-4320 Postage</b>					<b>\$1,196.45</b>	
		01-4324 Computer Software				
		Beginning Balance				1,711.56
12/15/2019	Bill	3119-CARD SERVICES (8365)		00-2010 Accounts Payable	15.30	1,726.86
<b>Total for 01-4324 Computer Software</b>					<b>\$15.30</b>	
		01-4326 Computer Hardware				
		Beginning Balance				570.54
12/15/2019	Bill	3119-CARD SERVICES (8365)		00-2010 Accounts Payable	566.70	1,137.24
<b>Total for 01-4326 Computer Hardware</b>					<b>\$566.70</b>	
		01-4328 Server Support				
		Beginning Balance				7,697.75
12/15/2019	Bill	3119-CARD SERVICES (8365)		00-2010 Accounts Payable	7,285.25	14,983.00
<b>Total for 01-4328 Server Support</b>					<b>\$7,285.25</b>	
		01-4330 Education & Training				
		Beginning Balance				855.00
<b>Total for 01-4330 Education &amp; Training</b>						
		01-4332 Travel				
		Beginning Balance				644.16
12/15/2019	Bill	3119-CARD SERVICES (8365)		00-2010 Accounts Payable	37.44	681.60
<b>Total for 01-4332 Travel</b>					<b>\$37.44</b>	
		01-4400 Contract Services				
		Beginning Balance				18,541.77
12/04/2019	Sales Receipt	STATE OF ALABAMA DEPARTMENT OF REVENUE		00-1299 Undeposited Funds	996.43	19,538.20
12/15/2019	Bill	3119-CARD SERVICES (8365)		00-2010 Accounts Payable	3,483.13	23,021.33
12/17/2019	Sales Receipt	STATE OF ALABAMA DEPARTMENT OF REVENUE	DEDUCTIONS FOR COST OF COLLECTIONS/ADJUSTMENTS:	00-1299 Undeposited Funds	165.74	23,187.07
<b>Total for 01-4400 Contract Services</b>					<b>\$4,645.30</b>	
		01-4402 Attorney/Legal				
		Beginning Balance				42,180.00
12/15/2019	Bill	2823-BRUNSON, BARNETT & SHERRER PC	LEGAL FEES	00-2010 Accounts Payable	19,340.00	61,520.00
<b>Total for 01-4402 Attorney/Legal</b>					<b>\$19,340.00</b>	
		01-4404 Auditing/Accounting				
		Beginning Balance				32,579.72
12/30/2019	Bill	1238-BMSS - BARFIELD MURPHY SHANK & SMITH		00-2010 Accounts Payable	18,490.40	51,070.12
<b>Total for 01-4404 Auditing/Accounting</b>					<b>\$18,490.40</b>	
		01-4500 Repair & Maint Auto				
		Beginning Balance				90.22
<b>Total for 01-4500 Repair &amp; Maint Auto</b>						
		01-4508 Repair & MTC - General				
		Beginning Balance				20,544.09
12/15/2019	Bill	3119-CARD SERVICES (8365)		00-2010 Accounts Payable	1,575.31	22,119.40
<b>Total for 01-4508 Repair &amp; MTC - General</b>					<b>\$1,575.31</b>	
		01-4520 Fuel Expense - Auto				
		Beginning Balance				28.17
12/30/2019	Bill	1770-WEX BANK	CLERK CAR	00-2010 Accounts Payable	51.52	79.69
<b>Total for 01-4520 Fuel Expense - Auto</b>					<b>\$51.52</b>	
		01-4702 Economic Redevelopment				
		Beginning Balance				3,616.66
12/15/2019	Bill	597-LEEDS CHAMBER OF COMMERCE	DECEMBER 2019	00-2010 Accounts Payable	1,808.33	5,424.99
<b>Total for 01-4702 Economic Redevelopment</b>					<b>\$1,808.33</b>	
		01-5011 City Prosecutor				
		Beginning Balance				14,000.00
12/30/2019	Bill	2120-BARNES & BARNES LAW FIRM PC	PROSECUTOR & APPEALS	00-2010 Accounts Payable	7,000.00	21,000.00

DATE	TRANSACTION NAME	MEMO/DESCRIPTION	SPLIT	AMOUNT	BALANCE
224					
<b>Total for 01-5011 City Prosecutor</b>				<b>\$7,000.00</b>	
01-6704	Asset Purchase				
12/06/2019	Check	2120-BARNES & BARNES LAW FIRM PC	CAPITAL ASSET -BUILDING AND PROPERTY 1412 9TH ST - CASH PURCHASE	00-1024 General Fund Checking Accounts:Gen'l Fund-Millennial-0036	919,909.75 919,909.75
<b>Total for 01-6704 Asset Purchase</b>				<b>\$919,909.75</b>	
01-7720	772 Grant Agreement				
	Beginning Balance				224,637.00
<b>Total for 01-7720 772 Grant Agreement</b>					
<b>Total for 01-4000 Admin Exp with subs</b>				<b>\$1,025,827.42</b>	
10-4000	Mayor				
10-4202	Mayor-Telephone				
	Beginning Balance				209.94
12/15/2019	Bill	3119-CARD SERVICES (8365)		00-2010 Accounts Payable	104.97 314.91
<b>Total for 10-4202 Mayor-Telephone</b>				<b>\$104.97</b>	
10-4203	Mayor-Cell/Wireless Services				
	Beginning Balance				154.58
12/15/2019	Bill	3119-CARD SERVICES (8365)		00-2010 Accounts Payable	156.76 311.34
<b>Total for 10-4203 Mayor-Cell/Wireless Services</b>				<b>\$156.76</b>	
10-4300	Mayor-Office Supplies				
	Beginning Balance				51.31
12/15/2019	Bill	3119-CARD SERVICES (8365)		00-2010 Accounts Payable	123.98 175.29
<b>Total for 10-4300 Mayor-Office Supplies</b>				<b>\$123.98</b>	
10-6702	Mayor-City Projects				
	Beginning Balance				2,500.00
12/10/2019	Bill	DONOHOO CHEVROLET LLC	2020 CHEV TAHOE - 1GNLCDEC1LR198318	00-2010 Accounts Payable	4,739.00 7,239.00
<b>Total for 10-6702 Mayor-City Projects</b>				<b>\$4,739.00</b>	
<b>Total for 10-4000 Mayor</b>				<b>\$5,124.71</b>	
11-4000	Court Exp				
11-4001	Court-Salaries & Wages				
	Beginning Balance				24,341.83
12/06/2019	Expense	PAYROLL & BENEFIT SOLUTIONS LLC (PBS)		00-1122 General Fund Checking Accounts:Payroll Acct-Servis 1st-1427	6,700.13 31,041.96
12/20/2019	Expense	PAYROLL & BENEFIT SOLUTIONS LLC (PBS)		00-1122 General Fund Checking Accounts:Payroll Acct-Servis 1st-1427	8,132.91 39,174.87
<b>Total for 11-4001 Court-Salaries &amp; Wages</b>				<b>\$14,833.04</b>	
11-4002	Court-Payroll Taxes				
	Beginning Balance				1,813.49
12/06/2019	Expense	PAYROLL & BENEFIT SOLUTIONS LLC (PBS)		00-1122 General Fund Checking Accounts:Payroll Acct-Servis 1st-1427	500.94 2,314.43
12/20/2019	Expense	PAYROLL & BENEFIT SOLUTIONS LLC (PBS)		00-1122 General Fund Checking Accounts:Payroll Acct-Servis 1st-1427	611.84 2,926.27
<b>Total for 11-4002 Court-Payroll Taxes</b>				<b>\$1,112.78</b>	
11-4004	Court-Health Insurance				
	Beginning Balance				2,706.00
12/06/2019	Expense	PAYROLL & BENEFIT SOLUTIONS LLC (PBS)		00-1122 General Fund Checking Accounts:Payroll Acct-Servis 1st-1427	-15.00 2,691.00
12/15/2019	Bill	2601-LOCAL GOVERNMENT HEALTH INSURANCE BOARD		00-2010 Accounts Payable	1,452.00 4,143.00
12/20/2019	Expense	PAYROLL & BENEFIT SOLUTIONS LLC (PBS)		00-1122 General Fund Checking Accounts:Payroll Acct-Servis 1st-1427	-15.00 4,128.00
<b>Total for 11-4004 Court-Health Insurance</b>				<b>\$1,422.00</b>	
11-4006	Court-Retirement				
	Beginning Balance				4,082.73
12/06/2019	Expense	851- Retirement Systems of Alabama		00-1114 General Fund Checking Accounts:Gen'l Fund-Servis 1st-4304	1,017.22 5,099.95
12/19/2019	Expense	851- Retirement Systems of Alabama		00-1114 General Fund Checking Accounts:Gen'l Fund-Servis 1st-4304	1,008.62 6,108.57
<b>Total for 11-4006 Court-Retirement</b>				<b>\$2,025.84</b>	



DATE	TRANSACTION NAME TYPE	MEMO/DESCRIPTION	SPLIT	AMOUNT	BALANCE
225					
11-4015	Court-EE Life & Disability Ins				
	Beginning Balance				131.28
12/30/2019	Bill 2725b-MUTUAL OF OMAHA		00-2010 Accounts Payable	22.93	154.21
<b>Total for 11-4015 Court-EE Life &amp; Disability Ins</b>				<b>\$22.93</b>	
11-4200	Court-Electrical Utilities				
	Beginning Balance				2,048.10
12/30/2019	Bill 111-ALABAMA POWER	35952-64013 POLICE	00-2010 Accounts Payable	794.32	2,842.42
<b>Total for 11-4200 Court-Electrical Utilities</b>				<b>\$794.32</b>	
11-4202	Court-Telephone Expense				
	Beginning Balance				148.25
12/15/2019	Bill 3119-CARD SERVICES (8365)		00-2010 Accounts Payable	148.41	296.66
<b>Total for 11-4202 Court-Telephone Expense</b>				<b>\$148.41</b>	
11-4203	Court-Cell / Wireless Services				
	Beginning Balance				209.47
12/15/2019	Bill 3119-CARD SERVICES (8365)		00-2010 Accounts Payable	145.94	355.41
<b>Total for 11-4203 Court-Cell / Wireless Services</b>				<b>\$145.94</b>	
11-4204	Court-Gas Utilities				
	Beginning Balance				58.12
<b>Total for 11-4204 Court-Gas Utilities</b>					
11-4206	Court-Water Utilities				
	Beginning Balance				44.26
12/15/2019	Bill 3119-CARD SERVICES (8365)		00-2010 Accounts Payable	42.85	87.11
<b>Total for 11-4206 Court-Water Utilities</b>				<b>\$42.85</b>	
11-4208	Court-Sewer Utilities				
	Beginning Balance				69.72
12/15/2019	Bill 3119-CARD SERVICES (8365)		00-2010 Accounts Payable	76.10	145.82
<b>Total for 11-4208 Court-Sewer Utilities</b>				<b>\$76.10</b>	
11-4300	Court-Office Supplies				
12/15/2019	Bill 3119-CARD SERVICES (8365)		00-2010 Accounts Payable	271.72	271.72
<b>Total for 11-4300 Court-Office Supplies</b>				<b>\$271.72</b>	
11-4304	Court-Copier & Printer Mtc				
	Beginning Balance				122.20
12/30/2019	Bill 3006-ROBERT J YOUNG COMPANY	COLOR	00-2010 Accounts Payable	152.82	275.02
12/30/2019	Bill 3006-ROBERT J YOUNG COMPANY	B/W	00-2010 Accounts Payable	38.51	313.53
<b>Total for 11-4304 Court-Copier &amp; Printer Mtc</b>				<b>\$191.33</b>	
11-4306	Court-Department Supplies				
	Beginning Balance				50.95
12/15/2019	Bill 3119-CARD SERVICES (8365)		00-2010 Accounts Payable	240.00	290.95
<b>Total for 11-4306 Court-Department Supplies</b>				<b>\$240.00</b>	
11-4314	Court-Subscriptions				
12/30/2019	Bill 2575-ALABAMA LAW ENFORCEMENT AGENCY	OCT-DEC 2019	00-2010 Accounts Payable	900.00	900.00
<b>Total for 11-4314 Court-Subscriptions</b>				<b>\$900.00</b>	
11-4316	Court-Dues & Fees				
	Beginning Balance				34.34
<b>Total for 11-4316 Court-Dues &amp; Fees</b>					
11-4400	Court-Contract Services				
	Beginning Balance				360.35
<b>Total for 11-4400 Court-Contract Services</b>					
11-4508	Court-Repair & MTC - Buildings				
12/18/2019	Bill 1332-K&K CONSTRUCTION INC	REPAIR TO COURT OFFICES FROM JAN 2019 DAMAGE	00-2010 Accounts Payable	47,309.24	47,309.24
<b>Total for 11-4508 Court-Repair &amp; MTC - Buildings</b>				<b>\$47,309.24</b>	
11-4520	Court-Fuel Expense - Auto				
	Beginning Balance				181.15
12/30/2019	Bill 1770-WEX BANK	COURT CAR	00-2010 Accounts Payable	29.38	210.53
<b>Total for 11-4520 Court-Fuel Expense - Auto</b>				<b>\$29.38</b>	
11-5000	Court-Govt Agencies Monthly Report Fees				
	Beginning Balance				17,980.79

DATE	TRANSACTION TYPE	NAME	MEMO/DESCRIPTION	SPLIT	AMOUNT	BALANCE
12/30/2019	Bill	1201A-DISTRICT ATTORNEY SOLICITORS FUND	NOV 2019 BAIL BOND FEES	00-2010 Accounts Payable	251.53	18,232.32
12/30/2019	Bill	1201B-DISTRICT ATTORNEY SOLICITORS FUND	NOV 2019 SOLICITOR FUND	00-2010 Accounts Payable	1,263.50	19,495.82
12/30/2019	Bill	1459B-DISTRICT ATTORNEY SOLICITORS FUND	NOV 2019 SOLICITOR FUND	00-2010 Accounts Payable	58.00	19,553.82
12/30/2019	Bill	2038-CIRCUIT CLERKS' JUDICIAL ADMIN FUND-JEFFERSON CO	NOV 2019	00-2010 Accounts Payable	189.44	19,743.26
12/30/2019	Bill	2040-CIRCUIT CLERKS' JUDICIAL ADMIN FUND-ST CLAIR CO	NOV 2019	00-2010 Accounts Payable	10.00	19,753.26
12/30/2019	Bill	2042-PRESIDING CIRCUIT JUDGES' JUDICIAL ADMIN FUND-ST CLAIR CO	NOV 2019	00-2010 Accounts Payable	10.00	19,763.26
12/30/2019	Bill	2041-PRESIDING CIRCUIT JUDGES' JUDICIAL ADMIN FUND-JEFF CO	NOV 2019	00-2010 Accounts Payable	188.78	19,952.04
12/30/2019	Bill	HIGHWAY TRAFFIC SAFETY FUND	NOV 2019	00-2010 Accounts Payable	120.00	20,072.04
12/30/2019	Bill	ALABAMA INTERLOCK INDIGENT FUND	NOV 2019	00-2010 Accounts Payable	68.00	20,140.04
12/30/2019	Bill	STATE JUDICIAL ADMIN FUND	NOV 2019	00-2010 Accounts Payable	913.84	21,053.88
12/30/2019	Bill	AMERICAN VILLAGE CITIZENSHIP TRUST FUND	NOV 2019	00-2010 Accounts Payable	81.00	21,134.88
12/30/2019	Bill	95-ALABAMA CRIME VICTIMS COMPENSATION COMMISSION	NOV 2019	00-2010 Accounts Payable	238.00	21,372.88
12/30/2019	Bill	109-ALABAMA PEACE OFFICERS' ANNUITY & BENEFIT FUND	NOV 2019	00-2010 Accounts Payable	457.00	21,829.88
12/30/2019	Bill	329-FINANCE DEPT-COMPTROLLER'S OFFICE	NOV 2019	00-2010 Accounts Payable	6,011.72	27,841.60
12/30/2019	Bill	2119-STONE LAW FIRM	NOV 2019 PUBLIC DEFENDER	00-2010 Accounts Payable	1,372.00	29,213.60
12/30/2019	Bill	1459A-DISTRICT ATTORNEY SOLICITORS FUND	NOV 2019 BAIL BOND FEES	00-2010 Accounts Payable	78.92	29,292.52
<b>Total for 11-5000 Court-Govt Agencies Monthly Report Fees</b>					<b>\$11,311.73</b>	
11-5002 Court-Restitution						
Beginning Balance						200.00
<b>Total for 11-5002 Court-Restitution</b>						
11-5004 Court-Court Bond Disposition						
12/30/2019	Bill	JOEY L KILPATRICK	MC17-0000675	00-2010 Accounts Payable	500.00	500.00
12/30/2019	Bill	BRITLEY M THOMAS	MC190000707	00-2010 Accounts Payable	500.00	1,000.00
<b>Total for 11-5004 Court-Court Bond Disposition</b>					<b>\$1,000.00</b>	
11-5010 Court-Municipal Judge						
Beginning Balance						5,000.00
12/30/2019	Bill	2943-CLIFTON S PRICE, III	MUNICIPAL JUDGE	00-2010 Accounts Payable	2,500.00	7,500.00
<b>Total for 11-5010 Court-Municipal Judge</b>					<b>\$2,500.00</b>	
11-6998 Court to Court Transfer						
Beginning Balance						9,341.68
12/30/2019	Bill	2845-LEEDS MUNICIPAL COURT DEFENSIVE DRIVING SCHOOL FUND	OCT 2019	00-2010 Accounts Payable	2,150.00	11,491.68
12/30/2019	Bill	2845-LEEDS MUNICIPAL COURT DEFENSIVE DRIVING SCHOOL FUND	NOV 2019	00-2010 Accounts Payable	1,650.00	13,141.68
12/30/2019	Bill	REGIONS-LEEDS MUNICIPAL COURT CORRECTIONS	NOV 2019 MONTHLY COLLECTIONS/COPY FEES/WRIT FEES/WARRANT RECALL FEES	00-2010 Accounts Payable	4,534.84	17,676.52
12/30/2019	Bill	REGIONS-LEEDS MUNICIPAL JUDICIAL ADMINISTRATIVE FUND	NOV 2019	00-2010 Accounts Payable	1,376.99	19,053.51
12/30/2019	Bill	REGIONS-LEEDS MUNICIPAL COURT MAGISTRATE TRAINING & EDUCATION FUND	NOV 2019 MONTHLY COLLECTION FOR TRAINING & EDUCATION	00-2010 Accounts Payable	194.50	19,248.01
<b>Total for 11-6998 Court to Court Transfer</b>					<b>\$9,906.33</b>	
11-6999 Court to GF Transfer						
Beginning Balance						-6,158.33
12/01/2019	Sales Receipt	DEFENSIVE DRIVING SCHOOL	CLOSING OF MILLENNIAL ACCOUNTS	00-1299 Undeposited Funds	-36,766.08	-42,924.41
12/02/2019	Sales Receipt	LEEDS COURT CORRECTIONS 9585	11152019	00-1299 Undeposited Funds	-7,198.32	-50,122.73
12/02/2019	Sales Receipt	MUNICIPAL JUDICIAL ADMIN	11152019	00-1299 Undeposited Funds	-1,835.86	-51,958.59
12/02/2019	Sales Receipt	MUNICIPAL JUDICIAL ADMIN	11152019	00-1299 Undeposited Funds	-307.50	-52,266.09
12/06/2019	Sales Receipt	LEEDS COURT COLLECTIONS - 9593	DECEMBER 06/2019	00-1299 Undeposited Funds	-3,960.00	-56,226.09
12/16/2019	Sales Receipt	DEFENSIVE DRIVING SCHOOL	TO VOID CHECK	00-1299 Undeposited Funds	-3,951.00	-60,177.09
12/16/2019	Sales Receipt	DEFENSIVE DRIVING SCHOOL	VOID CHECK	00-1299 Undeposited Funds	-4,207.50	-64,384.59
12/30/2019	Bill	REGIONS-LEEDS MUNICIPAL COURT CORRECTIONS	MILLENNIAL ACCOUNT CLOSEOUT TO REGIONS BANK ACCOUNT	00-2010 Accounts Payable	9,686.00	-54,698.59
12/30/2019	Bill	REGIONS-LEEDS MUNICIPAL COURT COLLECTIONS	MILLENNIAL ACCOUNT CLOSEOUT TO REGIONS BANK ACCOUNT	00-2010 Accounts Payable	36,856.00	-17,842.59
12/30/2019	Bill	REGIONS-LEEDS MUNICIPAL COURT CASH BONDS	MILLENNIAL ACCOUNT CLOSEOUT TO REGIONS BANK ACCOUNT	00-2010 Accounts Payable	4,982.68	-12,859.91
12/30/2019	Bill	66-CITY OF LEEDS - GENERAL FUND	NOV 2019 FINES/FEES/JAIL FEES/RESTITUTION	00-2010 Accounts Payable	28,996.28	16,136.37

DATE	TRANSACTION NAME	MEMO/DESCRIPTION	SPLIT	AMOUNT	BALANCE
227					
<b>Total for 11-6999 Court to GF Transfer</b>				<b>\$22,294.70</b>	
<b>Total for 11-4000 Court Exp</b>				<b>\$116,578.64</b>	
12-4000 Cemetery Exp					
Beginning Balance					
<b>Total for 12-4000 Cemetery Exp</b>					2,530.00
12-4206 Cemetery-Water Utilities					
Beginning Balance					
12/15/2019	Bill	3119-CARD SERVICES (8365)	00-2010 Accounts Payable	90.06	180.12
<b>Total for 12-4206 Cemetery-Water Utilities</b>				<b>\$90.06</b>	
12-4306 Cemetery-Department Supplies					
Beginning Balance					
<b>Total for 12-4306 Cemetery-Department Supplies</b>					47.76
12-4400 Cemetery-Contract Services					
Beginning Balance					
<b>Total for 12-4400 Cemetery-Contract Services</b>					11,295.00
<b>Total for 12-4000 Cemetery Exp with subs</b>				<b>\$90.06</b>	
13-4000 Council					
13-4001 Council-Salaries & Wages					
Beginning Balance					
12/31/2019	Expense	PAYROLL & BENEFIT SOLUTIONS LLC (PBS)	00-1122 General Fund Checking Accounts:Payroll Acct-Servis 1st-1427	6,050.00	18,150.00
<b>Total for 13-4001 Council-Salaries &amp; Wages</b>				<b>\$6,050.00</b>	
13-4002 Council-Payroll Taxes					
Beginning Balance					
12/31/2019	Expense	PAYROLL & BENEFIT SOLUTIONS LLC (PBS)	00-1122 General Fund Checking Accounts:Payroll Acct-Servis 1st-1427	468.28	1,404.79
<b>Total for 13-4002 Council-Payroll Taxes</b>				<b>\$468.28</b>	
<b>Total for 13-4000 Council</b>				<b>\$6,518.28</b>	
16-4000 Sr Citizens					
16-4306 Sr Citizens-Department Supplies					
Beginning Balance					
<b>Total for 16-4306 Sr Citizens-Department Supplies</b>					96.28
16-4400 Sr Citizens-Contract Services					
Beginning Balance					
12/30/2019	Bill	2710-PAUL ZUCKERMAN	DECEMBER CLASSES	320.00	1,720.00
<b>Total for 16-4400 Sr Citizens-Contract Services</b>				<b>\$320.00</b>	
<b>Total for 16-4000 Sr Citizens</b>				<b>\$320.00</b>	
19-4000 City Projects					
19-6102 Parks & Paving-City Projects					
Beginning Balance					
<b>Total for 19-6102 Parks &amp; Paving-City Projects</b>					237,389.00
19-6304 Hwy 78/Pres St-Engineering					
Beginning Balance					
12/15/2019	Bill	389-GOODWYN, MILLS & CAWOOD INC	CBHM1900504	10,136.50	48,777.00
<b>Total for 19-6304 Hwy 78/Pres St-Engineering</b>				<b>\$10,136.50</b>	
19-6702 Main St Al-City Projects					
Beginning Balance					
12/15/2019	Bill	2513-LEEDS REDEVELOPMENT AUTHORITY	PARKING LOT PROJECT PHASE III	45,062.50	203,813.16
12/15/2019	Bill	2513-LEEDS REDEVELOPMENT AUTHORITY	8347 RAILROAD AVE	42,163.02	245,976.18
12/30/2019	Bill	2513-LEEDS REDEVELOPMENT AUTHORITY	REIMBURSEMENT FOR CAUBLE ELECTRICAL CONTRACTOR INVOICE 2459.01	2,276.08	248,252.26
12/30/2019	Bill	2513-LEEDS REDEVELOPMENT AUTHORITY	REIMBURSEMENT FOR BLOUNT SPRINGS MATERIALS INVOICE 31438	240.18	248,492.44
12/30/2019	Bill	2513-LEEDS REDEVELOPMENT AUTHORITY	REIMBURSEMENT FOR BLOUNT SPRINGS MATERIALS INVOICE 31350	244.80	248,737.24
12/30/2019	Bill	2513-LEEDS REDEVELOPMENT AUTHORITY	HAGER CO LLC	1,250.00	249,987.24

DATE	TRANSACTION TYPE	NAME	MEMO/DESCRIPTION	SPLIT	AMOUNT	BALANCE
228						
12/30/2019	Bill	2513-LEEDS REDEVELOPMENT AUTHORITY	REIMBURSEMENT FOR BLOUNT SPRINGS MATERIALS INVOICE 31316	00-2010 Accounts Payable	492.59	250,479.83
12/30/2019	Bill	2513-LEEDS REDEVELOPMENT AUTHORITY	REIMBURSEMENT FOR BLOUNT SPRINGS MATERIALS INVOICE 31345	00-2010 Accounts Payable	242.22	250,722.05
<b>Total for 19-6702 Main St Al-City Projects</b>					<b>\$91,971.39</b>	
<b>Total for 19-4000 City Projects</b>					<b>\$102,107.89</b>	
22-4000 Police Exp						
22-4001 Police-Salaries & Wages						
Beginning Balance						241,296.88
12/06/2019	Expense	PAYROLL & BENEFIT SOLUTIONS LLC (PBS)		00-1122 General Fund Checking Accounts:Payroll Acct-Servis 1st-1427	66,380.38	307,677.26
12/20/2019	Expense	PAYROLL & BENEFIT SOLUTIONS LLC (PBS)		00-1122 General Fund Checking Accounts:Payroll Acct-Servis 1st-1427	56,340.52	364,017.78
<b>Total for 22-4001 Police-Salaries &amp; Wages</b>					<b>\$122,720.90</b>	
22-4002 Police-Payroll Taxes						
Beginning Balance						18,012.02
12/06/2019	Expense	PAYROLL & BENEFIT SOLUTIONS LLC (PBS)		00-1122 General Fund Checking Accounts:Payroll Acct-Servis 1st-1427	4,971.72	22,983.74
12/20/2019	Expense	PAYROLL & BENEFIT SOLUTIONS LLC (PBS)		00-1122 General Fund Checking Accounts:Payroll Acct-Servis 1st-1427	4,192.10	27,175.84
<b>Total for 22-4002 Police-Payroll Taxes</b>					<b>\$9,163.82</b>	
22-4004 Police-Health Insurance						
Beginning Balance						31,898.00
12/06/2019	Expense	PAYROLL & BENEFIT SOLUTIONS LLC (PBS)		00-1122 General Fund Checking Accounts:Payroll Acct-Servis 1st-1427	-1,747.50	30,150.50
12/15/2019	Bill	2601-LOCAL GOVERNMENT HEALTH INSURANCE BOARD		00-2010 Accounts Payable	22,755.00	52,905.50
12/20/2019	Expense	PAYROLL & BENEFIT SOLUTIONS LLC (PBS)		00-1122 General Fund Checking Accounts:Payroll Acct-Servis 1st-1427	-1,752.50	51,153.00
<b>Total for 22-4004 Police-Health Insurance</b>					<b>\$19,255.00</b>	
22-4006 Police-Retirement						
Beginning Balance						27,994.57
12/06/2019	Expense	851- Retirement Systems of Alabama		00-1114 General Fund Checking Accounts:Gen'l Fund-Servis 1st-4304	7,952.83	35,947.40
12/19/2019	Expense	851- Retirement Systems of Alabama		00-1114 General Fund Checking Accounts:Gen'l Fund-Servis 1st-4304	7,447.78	43,395.18
<b>Total for 22-4006 Police-Retirement</b>					<b>\$15,400.61</b>	
22-4012 Police-Uniforms						
Beginning Balance						1,136.69
12/15/2019	Bill	3119-CARD SERVICES (8365)		00-2010 Accounts Payable	302.19	1,438.88
<b>Total for 22-4012 Police-Uniforms</b>					<b>\$302.19</b>	
22-4014 Police-Other Benefits						
Beginning Balance						690.00
12/15/2019	Bill	109-ALABAMA PEACE OFFICERS' ANNUITY & BENEFIT FUND	DECEMBER 2019 DUES	00-2010 Accounts Payable	720.00	1,410.00
<b>Total for 22-4014 Police-Other Benefits</b>					<b>\$720.00</b>	
22-4015 Police-EE Life & Disability Ins						
Beginning Balance						1,159.48
12/30/2019	Bill	2725b-MUTUAL OF OMAHA		00-2010 Accounts Payable	242.05	1,401.53
<b>Total for 22-4015 Police-EE Life &amp; Disability Ins</b>					<b>\$242.05</b>	
22-4018 Police-Employment Expense						
Beginning Balance						890.00
12/15/2019	Bill	3119-CARD SERVICES (8365)		00-2010 Accounts Payable	270.00	1,160.00
<b>Total for 22-4018 Police-Employment Expense</b>					<b>\$270.00</b>	
22-4200 Police-Electrical Utilities						
Beginning Balance						2,182.32
12/15/2019	Bill	3119-CARD SERVICES (8365)		00-2010 Accounts Payable	97.76	2,280.08
12/30/2019	Bill	111-ALABAMA POWER	35952-64013	00-2010 Accounts Payable	794.32	3,074.40
<b>Total for 22-4200 Police-Electrical Utilities</b>					<b>\$892.08</b>	

DATE	TRANSACTION NAME	MEMO/DESCRIPTION	SPLIT	AMOUNT	BALANCE
229	TYPE				
22-4202	Police-Telephone				
	Beginning Balance				618.93
12/15/2019	Bill 3119-CARD SERVICES (8365)		00-2010 Accounts Payable	619.59	1,238.52
<b>Total for 22-4202 Police-Telephone</b>				<b>\$619.59</b>	
22-4203	Police-Cell / Wireless Services				
	Beginning Balance				1,034.42
12/15/2019	Bill 3119-CARD SERVICES (8365)		00-2010 Accounts Payable	1,034.42	2,068.84
<b>Total for 22-4203 Police-Cell / Wireless Services</b>				<b>\$1,034.42</b>	
22-4204	Police-Gas Utilities				
	Beginning Balance				66.64
<b>Total for 22-4204 Police-Gas Utilities</b>					
22-4206	Police-Water Utilities				
	Beginning Balance				44.26
12/15/2019	Bill 3119-CARD SERVICES (8365)		00-2010 Accounts Payable	42.85	87.11
<b>Total for 22-4206 Police-Water Utilities</b>				<b>\$42.85</b>	
22-4208	Police-Sewer Utilities				
	Beginning Balance				69.72
12/15/2019	Bill 3119-CARD SERVICES (8365)		00-2010 Accounts Payable	76.10	145.82
<b>Total for 22-4208 Police-Sewer Utilities</b>				<b>\$76.10</b>	
22-4300	Police-Office Supplies				
	Beginning Balance				145.78
12/15/2019	Bill 3119-CARD SERVICES (8365)		00-2010 Accounts Payable	287.31	433.09
<b>Total for 22-4300 Police-Office Supplies</b>				<b>\$287.31</b>	
22-4304	Police-Copier & Printer Mtc				
	Beginning Balance				163.77
12/15/2019	Bill 3119-CARD SERVICES (8365)		00-2010 Accounts Payable	87.17	250.94
<b>Total for 22-4304 Police-Copier &amp; Printer Mtc</b>				<b>\$87.17</b>	
22-4306	Police-Department Supplies				
	Beginning Balance				597.98
12/15/2019	Bill 3119-CARD SERVICES (8365)		00-2010 Accounts Payable	126.55	724.53
<b>Total for 22-4306 Police-Department Supplies</b>				<b>\$126.55</b>	
22-4312	Police-Printing				
12/15/2019	Bill 3119-CARD SERVICES (8365)		00-2010 Accounts Payable	164.00	164.00
<b>Total for 22-4312 Police-Printing</b>				<b>\$164.00</b>	
22-4314	Police-Subscriptions				
	Beginning Balance				3,670.00
12/15/2019	Bill 3119-CARD SERVICES (8365)		00-2010 Accounts Payable	205.54	3,875.54
<b>Total for 22-4314 Police-Subscriptions</b>				<b>\$205.54</b>	
22-4332	Police-Travel				
	Beginning Balance				88.44
<b>Total for 22-4332 Police-Travel</b>					
22-4400	Police-Contract Services				
	Beginning Balance				1,412.01
12/15/2019	Bill 2625 - GREATER BIRMINGHAM HUMANE SOCIETY	ANIMAL CONTROL	00-2010 Accounts Payable	1,771.91	3,183.92
12/30/2019	Bill 2625 - GREATER BIRMINGHAM HUMANE SOCIETY	NOVEMBER ANIMAL CONTROL	00-2010 Accounts Payable	1,801.41	4,985.33
<b>Total for 22-4400 Police-Contract Services</b>				<b>\$3,573.32</b>	
22-4412	Police-Community Program				
	Beginning Balance				4,262.69
<b>Total for 22-4412 Police-Community Program</b>					
22-4420	Police-Jail Expense				
	Beginning Balance				10,042.50
12/15/2019	Bill 2649-ST CLAIR COUNTY JAIL	LEEDS JAIL	00-2010 Accounts Payable	3,802.50	13,845.00
<b>Total for 22-4420 Police-Jail Expense</b>				<b>\$3,802.50</b>	
22-4500	Police-Repair & Maint Auto				
	Beginning Balance				1,408.67
12/15/2019	Bill 3119-CARD SERVICES (8365)		00-2010 Accounts Payable	5,077.83	6,486.50

DATE	TRANSACTION NAME	MEMO/DESCRIPTION	SPLIT	AMOUNT	BALANCE
230					
<b>Total for 22-4500 Police-Repair &amp; Maint Auto</b>				<b>\$5,077.83</b>	
22-4508 Police-Repair & MTC - Buildings					
Beginning Balance					
12/15/2019	Bill	3119-CARD SERVICES (8365)	00-2010 Accounts Payable	630.48	662.23
<b>Total for 22-4508 Police-Repair &amp; MTC - Buildings</b>				<b>\$630.48</b>	
22-4514 Police-Firing Range					
Beginning Balance					
12/15/2019	Bill	3119-CARD SERVICES (8365)	00-2010 Accounts Payable	1,635.38	3,635.38
<b>Total for 22-4514 Police-Firing Range</b>				<b>\$1,635.38</b>	
22-4520 Police-Fuel Expense - Auto					
Beginning Balance					
12/30/2019	Bill	1770-WEX BANK	PD 00-2010 Accounts Payable	3,771.52	12,981.10
<b>Total for 22-4520 Police-Fuel Expense - Auto</b>				<b>\$3,771.52</b>	
<b>Total for 22-4000 Police Exp</b>				<b>\$190,101.21</b>	
26-4000 Fire Exp					
26-4001 Fire-Salaries & Wages					
Beginning Balance					
12/06/2019	Expense	PAYROLL & BENEFIT SOLUTIONS LLC (PBS)	00-1122 General Fund Checking Accounts:Payroll Acct-Servis 1st-1427	61,850.42	291,726.26
12/20/2019	Expense	PAYROLL & BENEFIT SOLUTIONS LLC (PBS)	00-1122 General Fund Checking Accounts:Payroll Acct-Servis 1st-1427	62,619.49	354,345.75
<b>Total for 26-4001 Fire-Salaries &amp; Wages</b>				<b>\$124,469.91</b>	
26-4002 Fire-Payroll Taxes					
Beginning Balance					
12/06/2019	Expense	PAYROLL & BENEFIT SOLUTIONS LLC (PBS)	00-1122 General Fund Checking Accounts:Payroll Acct-Servis 1st-1427	4,519.35	21,290.53
12/20/2019	Expense	PAYROLL & BENEFIT SOLUTIONS LLC (PBS)	00-1122 General Fund Checking Accounts:Payroll Acct-Servis 1st-1427	4,603.57	25,894.10
<b>Total for 26-4002 Fire-Payroll Taxes</b>				<b>\$9,122.92</b>	
26-4004 Fire-Health Insurance					
Beginning Balance					
12/06/2019	Expense	PAYROLL & BENEFIT SOLUTIONS LLC (PBS)	00-1122 General Fund Checking Accounts:Payroll Acct-Servis 1st-1427	-2,611.25	35,052.75
12/15/2019	Bill	2601-LOCAL GOVERNMENT HEALTH INSURANCE BOARD	00-2010 Accounts Payable	25,744.00	60,796.75
12/20/2019	Expense	PAYROLL & BENEFIT SOLUTIONS LLC (PBS)	00-1122 General Fund Checking Accounts:Payroll Acct-Servis 1st-1427	-2,287.75	58,509.00
<b>Total for 26-4004 Fire-Health Insurance</b>				<b>\$20,845.00</b>	
26-4006 Fire-Retirement					
Beginning Balance					
12/06/2019	Expense	851- Retirement Systems of Alabama	00-1114 General Fund Checking Accounts:Gen'l Fund-Servis 1st-4304	7,952.83	35,947.39
12/19/2019	Expense	851- Retirement Systems of Alabama	00-1114 General Fund Checking Accounts:Gen'l Fund-Servis 1st-4304	7,447.78	43,395.17
<b>Total for 26-4006 Fire-Retirement</b>				<b>\$15,400.61</b>	
26-4012 Fire-Uniforms					
Beginning Balance					
12/15/2019	Bill	3119-CARD SERVICES (8365)	00-2010 Accounts Payable	1,256.67	1,530.08
<b>Total for 26-4012 Fire-Uniforms</b>				<b>\$1,256.67</b>	
26-4015 Fire-EE Life & Disability Ins					
Beginning Balance					
12/30/2019	Bill	2725b-MUTUAL OF OMAHA	00-2010 Accounts Payable	241.71	1,530.16
<b>Total for 26-4015 Fire-EE Life &amp; Disability Ins</b>				<b>\$241.71</b>	
26-4018 Fire-Employment Expense					
Beginning Balance					
12/15/2019	Bill	3119-CARD SERVICES (8365)	00-2010 Accounts Payable	109.98	294.70
<b>Total for 26-4018 Fire-Employment Expense</b>				<b>\$109.98</b>	

DATE	TRANSACTION NAME	MEMO/DESCRIPTION	SPLIT	AMOUNT	BALANCE
231					
26-4200 Fire-Electrical Utilities					
	Beginning				4,087.42
	Balance				
12/15/2019	Bill	3119-CARD SERVICES (8365)	00-2010 Accounts Payable	97.76	4,185.18
12/30/2019	Bill	111-ALABAMA POWER	00-2010 Accounts Payable	1,677.18	5,862.36
<b>Total for 26-4200 Fire-Electrical Utilities</b>				<b>\$1,774.94</b>	
26-4202 Fire-Cell / Wireless Services					
	Beginning				369.13
	Balance				
12/15/2019	Bill	3119-CARD SERVICES (8365)	00-2010 Accounts Payable	569.13	938.26
<b>Total for 26-4202 Fire-Cell / Wireless Services</b>				<b>\$569.13</b>	
26-4203 Fire-Telephone					
	Beginning				247.12
	Balance				
12/15/2019	Bill	3119-CARD SERVICES (8365)	00-2010 Accounts Payable	247.36	494.48
<b>Total for 26-4203 Fire-Telephone</b>				<b>\$247.36</b>	
26-4204 Fire-Gas Utilities					
	Beginning				960.63
	Balance				
<b>Total for 26-4204 Fire-Gas Utilities</b>					
26-4206 Fire-Water Utilities					
	Beginning				199.31
	Balance				
12/15/2019	Bill	3119-CARD SERVICES (8365)	00-2010 Accounts Payable	181.57	380.88
<b>Total for 26-4206 Fire-Water Utilities</b>				<b>\$181.57</b>	
26-4208 Fire-Sewer Utilites					
	Beginning				152.76
	Balance				
12/15/2019	Bill	3119-CARD SERVICES (8365)	00-2010 Accounts Payable	146.24	299.00
<b>Total for 26-4208 Fire-Sewer Utilites</b>				<b>\$146.24</b>	
26-4306 Fire-Department Supplies					
	Beginning				1,033.55
	Balance				
12/15/2019	Bill	3119-CARD SERVICES (8365)	00-2010 Accounts Payable	1,154.39	2,187.94
<b>Total for 26-4306 Fire-Department Supplies</b>				<b>\$1,154.39</b>	
26-4316 Fire-Dues & Fees					
	Beginning				865.00
	Balance				
12/15/2019	Bill	177-CENTRAL ALABAMA FIRE CHIEF'S ASSOC (CAFCA)	LEEDS FIRE DEPARTMENT	90.00	955.00
<b>Total for 26-4316 Fire-Dues &amp; Fees</b>				<b>\$90.00</b>	
26-4330 Fire-Education & Training					
	Beginning				5,624.96
	Balance				
12/15/2019	Bill	3119-CARD SERVICES (8365)	00-2010 Accounts Payable	1,262.51	6,887.47
<b>Total for 26-4330 Fire-Education &amp; Training</b>				<b>\$1,262.51</b>	
26-4332 Fire-Travel					
	Beginning				36.00
	Balance				
12/15/2019	Bill	3119-CARD SERVICES (8365)	00-2010 Accounts Payable	6.00	42.00
<b>Total for 26-4332 Fire-Travel</b>				<b>\$6.00</b>	
26-4400 Fire-Contract Services					
	Beginning				5,465.10
	Balance				
12/15/2019	Bill	3119-CARD SERVICES (8365)	00-2010 Accounts Payable	16.43	5,481.53
<b>Total for 26-4400 Fire-Contract Services</b>				<b>\$16.43</b>	
26-4412 Fire-Community Programs					
	Beginning				107.96
	Balance				
12/15/2019	Bill	3119-CARD SERVICES (8365)	00-2010 Accounts Payable	53.61	161.57
<b>Total for 26-4412 Fire-Community Programs</b>				<b>\$53.61</b>	
26-4500 Fire-Repair & Maint Auto					
	Beginning				6,042.64
	Balance				
12/15/2019	Bill	3119-CARD SERVICES (8365)	00-2010 Accounts Payable	823.27	6,865.91
12/15/2019	Bill	SOUTHERN VINTAGE FIRE APPARATUS ASSOC (SVFAA)	MEMBERSHIP FEE	100.00	6,965.91
<b>Total for 26-4500 Fire-Repair &amp; Maint Auto</b>				<b>\$923.27</b>	
26-4508 Fire-Repair & MTC - Building					
	Beginning				508.10
	Balance				
<b>Total for 26-4508 Fire-Repair &amp; MTC - Building</b>					

DATE	TRANSACTION NAME	MEMO/DESCRIPTION	SPLIT	AMOUNT	BALANCE
232					
26-4520	Fire-Fuel Expense - Auto				
	Beginning Balance				4,389.52
12/30/2019	Bill 1770-WEX BANK	FD	00-2010 Accounts Payable	2,078.66	6,468.18
<b>Total for 26-4520 Fire-Fuel Expense - Auto</b>				<b>\$2,078.66</b>	
26-4530	Fire-Department Tools				
	Beginning Balance				591.31
<b>Total for 26-4530 Fire-Department Tools</b>					
26-4540	Fire-Medical Supplies				
	Beginning Balance				5,155.60
12/15/2019	Bill 3119-CARD SERVICES (8365)		00-2010 Accounts Payable	1,015.95	6,171.55
<b>Total for 26-4540 Fire-Medical Supplies</b>				<b>\$1,015.95</b>	
26-4602	Fire-Rent - Fire Hydrants				
	Beginning Balance				2,112.90
12/15/2019	Bill 3119-CARD SERVICES (8365)		00-2010 Accounts Payable	2,112.90	4,225.80
<b>Total for 26-4602 Fire-Rent - Fire Hydrants</b>				<b>\$2,112.90</b>	
26-4700	Fire-Council approval				
12/15/2019	Bill 732-NAFECO INC	R2019-11-06	00-2010 Accounts Payable	699.00	699.00
<b>Total for 26-4700 Fire-Council approval</b>				<b>\$699.00</b>	
<b>Total for 26-4000 Fire Exp</b>				<b>\$183,778.76</b>	
33-4000	Depot				
33-4200	Depot-Electrical Utilities				
	Beginning Balance				711.05
12/30/2019	Bill 111-ALABAMA POWER	36012-65000 DEPOT	00-2010 Accounts Payable	431.87	1,142.92
<b>Total for 33-4200 Depot-Electrical Utilities</b>				<b>\$431.87</b>	
33-4206	Depot-Water Utilities				
	Beginning Balance				18.67
12/15/2019	Bill 3119-CARD SERVICES (8365)		00-2010 Accounts Payable	18.67	37.34
<b>Total for 33-4206 Depot-Water Utilities</b>				<b>\$18.67</b>	
<b>Total for 33-4000 Depot</b>				<b>\$450.54</b>	
34-4000	Visitor's Center				
34-4200	Visitor's Center-Electrical Utilities				
	Beginning Balance				426.62
12/30/2019	Bill 111-ALABAMA POWER	553242-67014	00-2010 Accounts Payable	76.81	503.43
<b>Total for 34-4200 Visitor's Center-Electrical Utilities</b>				<b>\$76.81</b>	
34-4204	Visitor's Center-Gas Utilities				
	Beginning Balance				84.53
<b>Total for 34-4204 Visitor's Center-Gas Utilities</b>					
34-4206	Visitor's Center-Water Utilities				
	Beginning Balance				18.67
12/15/2019	Bill 3119-CARD SERVICES (8365)		00-2010 Accounts Payable	18.67	37.34
<b>Total for 34-4206 Visitor's Center-Water Utilities</b>				<b>\$18.67</b>	
34-4208	Visitor's Center-Sewer Utilities				
	Beginning Balance				28.19
12/15/2019	Bill 3119-CARD SERVICES (8365)		00-2010 Accounts Payable	36.61	64.80
<b>Total for 34-4208 Visitor's Center-Sewer Utilities</b>				<b>\$36.61</b>	
34-4400	Visitor's Center-Contract Services				
	Beginning Balance				492.71
<b>Total for 34-4400 Visitor's Center-Contract Services</b>					
34-4508	Visitor's Center-Repair & MTC - Building				
	Beginning Balance				17,547.23
<b>Total for 34-4508 Visitor's Center-Repair &amp; MTC - Building</b>					
<b>Total for 34-4000 Visitor's Center</b>				<b>\$132.09</b>	
40-4000	Parks Exp				
40-4001	Parks-Salaries & Wages				
	Beginning Balance				9,134.82
12/06/2019	Expense PAYROLL & BENEFIT SOLUTIONS LLC (PBS)		00-1122 General Fund Checking Accounts:Payroll Acct-Servis 1st-1427	2,406.07	11,540.89



DATE	TRANSACTION TYPE	NAME	MEMO/DESCRIPTION	SPLIT	AMOUNT	BALANCE
12/20/2019	Expense	PAYROLL & BENEFIT SOLUTIONS LLC (PBS)		00-1122 General Fund Checking Accounts:Payroll Acct-Servis 1st-1427	2,273.30	13,814.19
<b>Total for 40-4001 Parks-Salaries &amp; Wages</b>					<b>\$4,679.37</b>	
40-4002 Parks-Payroll Taxes						
Beginning Balance						
12/06/2019	Expense	PAYROLL & BENEFIT SOLUTIONS LLC (PBS)		00-1122 General Fund Checking Accounts:Payroll Acct-Servis 1st-1427	186.24	893.28
12/20/2019	Expense	PAYROLL & BENEFIT SOLUTIONS LLC (PBS)		00-1122 General Fund Checking Accounts:Payroll Acct-Servis 1st-1427	175.95	1,069.23
<b>Total for 40-4002 Parks-Payroll Taxes</b>					<b>\$362.19</b>	
40-4006 Parks-Retirement						
Beginning Balance						
12/06/2019	Expense	851- Retirement Systems of Alabama		00-1114 General Fund Checking Accounts:Gen'l Fund-Servis 1st-4304	1,017.22	5,099.95
12/19/2019	Expense	851- Retirement Systems of Alabama		00-1114 General Fund Checking Accounts:Gen'l Fund-Servis 1st-4304	1,008.62	6,108.57
<b>Total for 40-4006 Parks-Retirement</b>					<b>\$2,025.84</b>	
40-4015 Parks-Ee Life & Disability Ins						
Beginning Balance						
12/30/2019	Bill	2725b-MUTUAL OF OMAHA		00-2010 Accounts Payable	8.73	69.01
<b>Total for 40-4015 Parks-Ee Life &amp; Disability Ins</b>					<b>\$8.73</b>	
40-4200 Parks-Electrical Utilities						
Beginning Balance						
12/30/2019	Bill	111-ALABAMA POWER		00-2010 Accounts Payable	5,198.70	18,269.76
<b>Total for 40-4200 Parks-Electrical Utilities</b>					<b>\$5,198.70</b>	
40-4202 Parks-Cell / Wireless Services						
12/15/2019	Bill	3119-CARD SERVICES (8365)		00-2010 Accounts Payable	29.99	29.99
<b>Total for 40-4202 Parks-Cell / Wireless Services</b>					<b>\$29.99</b>	
40-4203 Parks-Telephone						
Beginning Balance						
12/15/2019	Bill	3119-CARD SERVICES (8365)		00-2010 Accounts Payable	53.35	83.31
<b>Total for 40-4203 Parks-Telephone</b>					<b>\$53.35</b>	
40-4204 Parks-Gas Utilities						
Beginning Balance						
<b>Total for 40-4204 Parks-Gas Utilities</b>						405.48
40-4206 Parks-Water Utilites						
Beginning Balance						
12/15/2019	Bill	3119-CARD SERVICES (8365)		00-2010 Accounts Payable	499.61	1,474.87
<b>Total for 40-4206 Parks-Water Utilites</b>					<b>\$499.61</b>	
40-4208 Parks-Sewer Utilites						
Beginning Balance						
12/15/2019	Bill	3119-CARD SERVICES (8365)		00-2010 Accounts Payable	90.77	181.90
<b>Total for 40-4208 Parks-Sewer Utilites</b>					<b>\$90.77</b>	
40-4306 Parks-Department Supplies						
Beginning Balance						
12/15/2019	Bill	3119-CARD SERVICES (8365)		00-2010 Accounts Payable	118.00	903.50
<b>Total for 40-4306 Parks-Department Supplies</b>					<b>\$118.00</b>	
40-4400 Parks-Contract Services						
Beginning Balance						
12/15/2019	Bill	3119-CARD SERVICES (8365)		00-2010 Accounts Payable	1,079.23	8,695.44
<b>Total for 40-4400 Parks-Contract Services</b>					<b>\$1,079.23</b>	
40-4414 Parks-Downtown Beautification						
Beginning Balance						
12/15/2019	Bill	3119-CARD SERVICES (8365)		00-2010 Accounts Payable	836.97	1,933.75
12/15/2019	Bill	2219-CAUBLE ELECTRICAL CONTRACTOR INC	LEEDS CHRISTMAS TREE LIGHTS	00-2010 Accounts Payable	50.00	1,983.75
12/30/2019	Bill	TEMPLE DISPLAY LTD		00-2010 Accounts Payable	225.01	2,208.76
<b>Total for 40-4414 Parks-Downtown Beautification</b>					<b>\$1,111.98</b>	

DATE	TRANSACTION NAME TYPE	MEMO/DESCRIPTION	SPLIT	AMOUNT	BALANCE
234					
40-4416	Parks-Tree Commission				
	Beginning Balance				81.50
<b>Total for 40-4416 Parks-Tree Commission</b>					
40-4500	Parks-Repair & MTC - Auto				
	Beginning Balance				50.00
<b>Total for 40-4500 Parks-Repair &amp; MTC - Auto</b>					
40-4508	Parks-Repair & MTC - Building				
	Beginning Balance				220.48
12/30/2019	Bill	1282-JEFFERSON COUNTY COMMISSION	PERMIT 20193441 - LEEDS MEMORIAL PARK CONCESSIONS	00-2010 Accounts Payable	435.37
					655.85
<b>Total for 40-4508 Parks-Repair &amp; MTC - Building</b>				<b>\$435.37</b>	
<b>Total for 40-4000 Parks Exp</b>				<b>\$15,693.13</b>	
50-4000	Development Exp				
50-4001	Development-Salaries & Wages				
	Beginning Balance				23,696.79
12/06/2019	Expense	PAYROLL & BENEFIT SOLUTIONS LLC (PBS)		00-1122 General Fund Checking Accounts:Payroll Acct-Servis 1st-1427	6,312.18
					30,008.97
12/20/2019	Expense	PAYROLL & BENEFIT SOLUTIONS LLC (PBS)		00-1122 General Fund Checking Accounts:Payroll Acct-Servis 1st-1427	5,506.83
					35,515.80
<b>Total for 50-4001 Development-Salaries &amp; Wages</b>				<b>\$11,819.01</b>	
50-4002	Development-Payroll Taxes				
	Beginning Balance				1,768.76
12/06/2019	Expense	PAYROLL & BENEFIT SOLUTIONS LLC (PBS)		00-1122 General Fund Checking Accounts:Payroll Acct-Servis 1st-1427	472.21
					2,240.97
12/20/2019	Expense	PAYROLL & BENEFIT SOLUTIONS LLC (PBS)		00-1122 General Fund Checking Accounts:Payroll Acct-Servis 1st-1427	409.89
					2,650.86
<b>Total for 50-4002 Development-Payroll Taxes</b>				<b>\$882.10</b>	
50-4004	Development-Health Insurance				
	Beginning Balance				3,435.00
12/06/2019	Expense	PAYROLL & BENEFIT SOLUTIONS LLC (PBS)		00-1122 General Fund Checking Accounts:Payroll Acct-Servis 1st-1427	-171.75
					3,263.25
12/15/2019	Bill	2601-LOCAL GOVERNMENT HEALTH INSURANCE BOARD		00-2010 Accounts Payable	2,164.00
					5,427.25
12/20/2019	Expense	PAYROLL & BENEFIT SOLUTIONS LLC (PBS)		00-1122 General Fund Checking Accounts:Payroll Acct-Servis 1st-1427	-171.75
					5,255.50
<b>Total for 50-4004 Development-Health Insurance</b>				<b>\$1,820.50</b>	
50-4006	Development-Retirement				
	Beginning Balance				4,082.73
12/06/2019	Expense	851- Retirement Systems of Alabama		00-1114 General Fund Checking Accounts:Gen'l Fund-Servis 1st-4304	1,017.22
					5,099.95
12/19/2019	Expense	851- Retirement Systems of Alabama		00-1114 General Fund Checking Accounts:Gen'l Fund-Servis 1st-4304	1,008.62
					6,108.57
<b>Total for 50-4006 Development-Retirement</b>				<b>\$2,025.84</b>	
50-4012	Development-Uniforms				
	Beginning Balance				492.89
<b>Total for 50-4012 Development-Uniforms</b>					
50-4015	Development-Ee Life & Disability Ins				
	Beginning Balance				162.03
12/30/2019	Bill	2725b-MUTUAL OF OMAHA		00-2010 Accounts Payable	29.08
					191.11
<b>Total for 50-4015 Development-Ee Life &amp; Disability Ins</b>				<b>\$29.08</b>	
50-4131	Development-Const. Ind. Craft Train				
	Beginning Balance				1,037.00
12/15/2019	Bill	2930-CRAFT TRAINING FUND	NOV 2019 CRAFT FEE	00-2010 Accounts Payable	299.00
					1,336.00
<b>Total for 50-4131 Development-Const. Ind. Craft Train</b>				<b>\$299.00</b>	
50-4200	Development-Electrical Utilities				
	Beginning Balance				346.45
12/30/2019	Bill	111-ALABAMA POWER		00-2010 Accounts Payable	177.05
					523.50

DATE	TRANSACTION NAME	MEMO/DESCRIPTION	SPLIT	AMOUNT	BALANCE
235	TYPE				
<b>Total for 50-4200 Development-Electrical Utilities</b>				<b>\$177.05</b>	
50-4202 Development-Telephone					
Beginning Balance					
12/15/2019	Bill	3119-CARD SERVICES (8365)	00-2010 Accounts Payable	95.55	191.01
<b>Total for 50-4202 Development-Telephone</b>				<b>\$95.55</b>	
50-4203 Development-Cell / Wireless Services					
Beginning Balance					
12/15/2019	Bill	3119-CARD SERVICES (8365)	00-2010 Accounts Payable	184.41	368.75
<b>Total for 50-4203 Development-Cell / Wireless Services</b>				<b>\$184.41</b>	
50-4206 Development-Water Utilities					
Beginning Balance					
12/15/2019	Bill	3119-CARD SERVICES (8365)	00-2010 Accounts Payable	18.67	37.58
<b>Total for 50-4206 Development-Water Utilities</b>				<b>\$18.67</b>	
50-4208 Development-Sewer Utilities					
Beginning Balance					
12/15/2019	Bill	3119-CARD SERVICES (8365)	00-2010 Accounts Payable	28.66	56.56
<b>Total for 50-4208 Development-Sewer Utilities</b>				<b>\$28.66</b>	
50-4300 Development-Office Supplies					
Beginning Balance					
<b>Total for 50-4300 Development-Office Supplies</b>					56.03
50-4303 Development-Copier & Printer Mtc					
Beginning Balance					
12/15/2019	Bill	3119-CARD SERVICES (8365)	00-2010 Accounts Payable	147.56	460.50
<b>Total for 50-4303 Development-Copier &amp; Printer Mtc</b>				<b>\$147.56</b>	
50-4306 Development-Department Supplies					
Beginning Balance					
12/15/2019	Bill	3119-CARD SERVICES (8365)	00-2010 Accounts Payable	303.72	370.21
<b>Total for 50-4306 Development-Department Supplies</b>				<b>\$303.72</b>	
50-4316 Development-Dues & Fees					
12/15/2019	Bill	3119-CARD SERVICES (8365)	00-2010 Accounts Payable	165.00	165.00
<b>Total for 50-4316 Development-Dues &amp; Fees</b>				<b>\$165.00</b>	
50-4324 Development-Computer Software					
Beginning Balance					
<b>Total for 50-4324 Development-Computer Software</b>					85.94
50-4326 Development-Computer Hardware					
Beginning Balance					
12/15/2019	Bill	3119-CARD SERVICES (8365)	00-2010 Accounts Payable	1,405.13	2,142.31
<b>Total for 50-4326 Development-Computer Hardware</b>				<b>\$1,405.13</b>	
50-4332 Development-Travel					
Beginning Balance					
<b>Total for 50-4332 Development-Travel</b>					70.33
50-4400 Development-Contract Services					
Beginning Balance					
<b>Total for 50-4400 Development-Contract Services</b>					671.71
50-4406 Development-Engineer Services					
Beginning Balance					
12/15/2019	Bill	HAGERCO LLC	Review & Site Visit for Rockhampton subdivision	550.00	1,469.67
<b>Total for 50-4406 Development-Engineer Services</b>				<b>\$550.00</b>	
50-4412 Development-Community Programs					
Beginning Balance					
12/30/2019	Bill	1584- GUARDIAN SYSTEMS INC	GUARDIAN SYSTEMS INC 12/16/20119	110.00	8,098.18
<b>Total for 50-4412 Development-Community Programs</b>				<b>\$110.00</b>	
50-4500 Development-Repair & Maint Auto					
Beginning Balance					
12/15/2019	Bill	3119-CARD SERVICES (8365)	00-2010 Accounts Payable	654.88	1,174.66
<b>Total for 50-4500 Development-Repair &amp; Maint Auto</b>				<b>\$654.88</b>	
50-4520 Development-Fuel Expense - Auto					

DATE	TRANSACTION TYPE	NAME	MEMO/DESCRIPTION	SPLIT	AMOUNT	BALANCE
236						
						419.00
	Beginning Balance					
12/30/2019	Bill	1770-WEX BANK	DEVELOPMENT SERVICES	00-2010 Accounts Payable	254.07	673.07
<b>Total for 50-4520 Development-Fuel Expense - Auto</b>					<b>\$254.07</b>	
	50-6500 Development-Taxes & Recording Fees					
	Beginning Balance					73.49
<b>Total for 50-6500 Development-Taxes &amp; Recording Fees</b>						
<b>Total for 50-4000 Development Exp</b>					<b>\$20,970.23</b>	
	51-4000 Storm Water Exp					
	51-4318 Storm Water - Dues & Fees-Govt					
12/15/2019	Bill	ALABAMA DEPT OF REVENUE	2020 CHEV TAHOE 1GNLCDEC5LR198287	00-2010 Accounts Payable	24.25	24.25
12/15/2019	Bill	ALABAMA DEPT OF REVENUE	2020 CHEV TAHOE 1GNLCDEC0LR198357	00-2010 Accounts Payable	24.25	48.50
<b>Total for 51-4318 Storm Water - Dues &amp; Fees-Govt</b>					<b>\$48.50</b>	
	51-4412 Storm Water - Community Programs					
	Beginning Balance					301.00
12/12/2019	Bill	DONOHOO CHEVROLET LLC	2020 CHEV TAHOE - 1GNLCDEC0LR198357	00-2010 Accounts Payable	30,739.00	31,040.00
12/12/2019	Bill	DONOHOO CHEVROLET LLC	2020 CHEV TAHOE - 1GNLCDEC5LR198287	00-2010 Accounts Payable	30,739.00	61,779.00
<b>Total for 51-4412 Storm Water - Community Programs</b>					<b>\$61,478.00</b>	
<b>Total for 51-4000 Storm Water Exp</b>					<b>\$61,526.50</b>	
	70-4000 Library					
12/15/2019	Bill	2975-MIDAMERICA BOOKS	BOOKS	00-2010 Accounts Payable	75.80	75.80
<b>Total for 70-4000 Library</b>					<b>\$75.80</b>	
	70-4001 Library-Salaries & Wages					
	Beginning Balance					36,642.43
12/06/2019	Expense	PAYROLL & BENEFIT SOLUTIONS LLC (PBS)		00-1122 General Fund Checking Accounts:Payroll Acct-Servis 1st-1427	9,018.51	45,660.94
12/20/2019	Expense	PAYROLL & BENEFIT SOLUTIONS LLC (PBS)		00-1122 General Fund Checking Accounts:Payroll Acct-Servis 1st-1427	9,172.24	54,833.18
<b>Total for 70-4001 Library-Salaries &amp; Wages</b>					<b>\$18,190.75</b>	
	70-4002 Library-Payroll Taxes					
	Beginning Balance					2,765.63
12/06/2019	Expense	PAYROLL & BENEFIT SOLUTIONS LLC (PBS)		00-1122 General Fund Checking Accounts:Payroll Acct-Servis 1st-1427	680.42	3,446.05
12/20/2019	Expense	PAYROLL & BENEFIT SOLUTIONS LLC (PBS)		00-1122 General Fund Checking Accounts:Payroll Acct-Servis 1st-1427	692.30	4,138.35
<b>Total for 70-4002 Library-Payroll Taxes</b>					<b>\$1,372.72</b>	
	70-4004 Library-Health Insurance					
	Beginning Balance					5,219.00
12/06/2019	Expense	PAYROLL & BENEFIT SOLUTIONS LLC (PBS)		00-1122 General Fund Checking Accounts:Payroll Acct-Servis 1st-1427	-186.75	5,032.25
12/15/2019	Bill	2601-LOCAL GOVERNMENT HEALTH INSURANCE BOARD		00-2010 Accounts Payable	3,132.00	8,164.25
12/20/2019	Expense	PAYROLL & BENEFIT SOLUTIONS LLC (PBS)		00-1122 General Fund Checking Accounts:Payroll Acct-Servis 1st-1427	-186.75	7,977.50
<b>Total for 70-4004 Library-Health Insurance</b>					<b>\$2,758.50</b>	
	70-4006 Library-Retirement					
	Beginning Balance					4,082.74
12/06/2019	Expense	851- Retirement Systems of Alabama		00-1114 General Fund Checking Accounts:Gen'l Fund-Servis 1st-4304	1,017.21	5,099.95
12/19/2019	Expense	851- Retirement Systems of Alabama		00-1114 General Fund Checking Accounts:Gen'l Fund-Servis 1st-4304	1,008.62	6,108.57
<b>Total for 70-4006 Library-Retirement</b>					<b>\$2,025.83</b>	
	70-4015 Library-Ee Life & Disability Ins					
	Beginning Balance					210.98
12/30/2019	Bill	2725b-MUTUAL OF OMAHA		00-2010 Accounts Payable	38.87	249.85
<b>Total for 70-4015 Library-Ee Life &amp; Disability Ins</b>					<b>\$38.87</b>	
	70-4200 Library-Electrical Utilities					
	Beginning Balance					1,688.68
12/30/2019	Bill	111-ALABAMA POWER	39172-670074	00-2010 Accounts Payable	558.11	2,246.79

DATE	TRANSACTION NAME	MEMO/DESCRIPTION	SPLIT	AMOUNT	BALANCE
237	TYPE				
<b>Total for 70-4200 Library-Electrical Utilities</b>				<b>\$558.11</b>	
70-4203 Library-Cell / Wireless Services					
Beginning Balance					
12/15/2019	Bill	3119-CARD SERVICES (8365)	00-2010 Accounts Payable	69.21	121.72
<b>Total for 70-4203 Library-Cell / Wireless Services</b>				<b>\$69.21</b>	
70-4204 Library-Gas Utilities					
Beginning Balance					
<b>Total for 70-4204 Library-Gas Utilities</b>					46.87
70-4206 Library-Water Utilities					
Beginning Balance					
12/15/2019	Bill	3119-CARD SERVICES (8365)	00-2010 Accounts Payable	18.67	37.34
<b>Total for 70-4206 Library-Water Utilities</b>				<b>\$18.67</b>	
70-4208 Library-Sewer Utilities					
Beginning Balance					
12/15/2019	Bill	3119-CARD SERVICES (8365)	00-2010 Accounts Payable	62.58	123.08
<b>Total for 70-4208 Library-Sewer Utilities</b>				<b>\$62.58</b>	
70-4300 Library-Office Supplies					
Beginning Balance					
12/15/2019	Bill	3119-CARD SERVICES (8365)	00-2010 Accounts Payable	13.20	171.05
<b>Total for 70-4300 Library-Office Supplies</b>				<b>\$13.20</b>	
70-4306 Library-Department Supplies					
Beginning Balance					
<b>Total for 70-4306 Library-Department Supplies</b>					748.94
70-4308 Library-Pr Advertising					
12/15/2019	Bill	3119-CARD SERVICES (8365)	00-2010 Accounts Payable	499.00	499.00
<b>Total for 70-4308 Library-Pr Advertising</b>				<b>\$499.00</b>	
70-4314 Library-Subscriptions					
Beginning Balance					
<b>Total for 70-4314 Library-Subscriptions</b>					1,503.71
70-4316 Library-Dues & Fees					
Beginning Balance					
<b>Total for 70-4316 Library-Dues &amp; Fees</b>					374.00
70-4326 Library-Computer Hardware					
Beginning Balance					
<b>Total for 70-4326 Library-Computer Hardware</b>					314.96
70-4330 Library-Education & Training					
Beginning Balance					
12/15/2019	Bill	2829-VIRGINIA EDWARDS	REIMBURSEMENT FOR LIBRARY CONFERENCE	1,003.64	1,052.64
12/15/2019	Bill	3119-CARD SERVICES (8365)		-25.00	1,027.64
12/15/2019	Bill	2829-VIRGINIA EDWARDS	REIMBURSEMENT FOR LIBRARY CONFERENCE REGISTRATION.	374.00	1,401.64
<b>Total for 70-4330 Library-Education &amp; Training</b>				<b>\$1,352.64</b>	
70-4332 Library-Travel					
Beginning Balance					
<b>Total for 70-4332 Library-Travel</b>					431.48
70-4350 Library-Books - Juvenile					
Beginning Balance					
12/15/2019	Bill	476-INGRAM LIBRARY SERVICES	BOOKS	30.80	445.23
12/15/2019	Bill	476-INGRAM LIBRARY SERVICES	BOOKS	12.46	457.69
12/15/2019	Bill	3119-CARD SERVICES (8365)		705.03	1,162.72
12/15/2019	Bill	476-INGRAM LIBRARY SERVICES	BOOKS	34.08	1,196.80
<b>Total for 70-4350 Library-Books - Juvenile</b>				<b>\$782.37</b>	
70-4352 Library-Books - Adult					
Beginning Balance					
12/15/2019	Bill	476-INGRAM LIBRARY SERVICES	42796946	18.56	1,314.56
12/15/2019	Bill	476-INGRAM LIBRARY SERVICES	42796945	19.77	1,334.33
12/15/2019	Bill	476-INGRAM LIBRARY SERVICES	42757729	18.11	1,352.44
12/15/2019	Bill	476-INGRAM LIBRARY SERVICES	42757728	19.41	1,371.85

DATE	TRANSACTION TYPE	NAME	MEMO/DESCRIPTION	SPLIT	AMOUNT	BALANCE
238						
12/15/2019	Bill	476-INGRAM LIBRARY SERVICES		00-2010 Accounts Payable	30.77	1,402.62
12/15/2019	Bill	476-INGRAM LIBRARY SERVICES	BOOKS	00-2010 Accounts Payable	16.89	1,419.51
12/15/2019	Bill	476-INGRAM LIBRARY SERVICES	BOOKS	00-2010 Accounts Payable	210.59	1,630.10
12/15/2019	Bill	476-INGRAM LIBRARY SERVICES		00-2010 Accounts Payable	32.89	1,662.99
12/15/2019	Bill	693-MICROMARKETING LLC	BOOKS	00-2010 Accounts Payable	129.61	1,792.60
12/15/2019	Bill	476-INGRAM LIBRARY SERVICES	42796947	00-2010 Accounts Payable	34.67	1,827.27
12/15/2019	Bill	476-INGRAM LIBRARY SERVICES	42812966	00-2010 Accounts Payable	33.05	1,860.32
12/15/2019	Bill	476-INGRAM LIBRARY SERVICES	42812967	00-2010 Accounts Payable	17.95	1,878.27
12/15/2019	Bill	476-INGRAM LIBRARY SERVICES	42812969	00-2010 Accounts Payable	29.44	1,907.71
12/15/2019	Bill	476-INGRAM LIBRARY SERVICES	42812968	00-2010 Accounts Payable	63.33	1,971.04
12/15/2019	Bill	476-INGRAM LIBRARY SERVICES	42812970	00-2010 Accounts Payable	313.66	2,284.70
12/15/2019	Bill	476-INGRAM LIBRARY SERVICES	42827200	00-2010 Accounts Payable	38.17	2,322.87
<b>Total for 70-4352 Library-Books - Adult</b>					<b>\$1,026.87</b>	
70-4354 Library-Audio/Video						
Beginning Balance						
						1,241.47
12/15/2019	Bill	3119-CARD SERVICES (8365)		00-2010 Accounts Payable	40.38	1,281.85
<b>Total for 70-4354 Library-Audio/Video</b>					<b>\$40.38</b>	
70-4356 Library-Jeff Co Library System						
Beginning Balance						
						9,869.32
12/15/2019	Bill	1704a-DELL FINANCIAL SERVICES	RENEWAL	00-2010 Accounts Payable	52.32	9,921.64
12/15/2019	Bill	1704a-DELL FINANCIAL SERVICES	RENEWAL	00-2010 Accounts Payable	65.32	9,986.96
12/15/2019	Bill	1704a-DELL FINANCIAL SERVICES	RENEWAL	00-2010 Accounts Payable	130.64	10,117.60
12/15/2019	Bill	2997-UNITI FIBER /dba/ CONTACT NETWORK/INLINE	LIBRARY	00-2010 Accounts Payable	1,054.70	11,172.30
12/15/2019	Bill	3119-CARD SERVICES (8365)		00-2010 Accounts Payable	353.22	11,525.52
12/15/2019	Bill	1704a-DELL FINANCIAL SERVICES	RENEWAL	00-2010 Accounts Payable	104.64	11,630.16
<b>Total for 70-4356 Library-Jeff Co Library System</b>					<b>\$1,760.84</b>	
70-4400 Library-Contract Services						
Beginning Balance						
						741.99
12/15/2019	Bill	3119-CARD SERVICES (8365)		00-2010 Accounts Payable	42.12	784.11
<b>Total for 70-4400 Library-Contract Services</b>					<b>\$42.12</b>	
70-4412 Library-Community Programs						
Beginning Balance						
						1,506.49
12/15/2019	Bill	3119-CARD SERVICES (8365)		00-2010 Accounts Payable	180.83	1,687.32
<b>Total for 70-4412 Library-Community Programs</b>					<b>\$180.83</b>	
70-4508 Library-Repair & MTC						
Beginning Balance						
						414.95
12/15/2019	Bill	3119-CARD SERVICES (8365)		00-2010 Accounts Payable	610.00	1,024.95
12/15/2019	Bill	2219-CAUBLE ELECTRICAL CONTRACTOR INC		00-2010 Accounts Payable	299.57	1,324.52
<b>Total for 70-4508 Library-Repair &amp; MTC</b>					<b>\$909.57</b>	
70-4600 Library-Rent - Building						
Beginning Balance						
						2,000.00
12/30/2019	Bill	631-FRANK W LITTLE - LIBRARY RENT	DEC 2019 LIBRARY RENT	00-2010 Accounts Payable	1,000.00	3,000.00
<b>Total for 70-4600 Library-Rent - Building</b>					<b>\$1,000.00</b>	
70-4601 LIBRARY EXPENSES						
Beginning Balance						
						644.08
12/15/2019	Bill	693-MICROMARKETING LLC	BOOKS	00-2010 Accounts Payable	345.00	989.08
12/15/2019	Bill	693-MICROMARKETING LLC	BOOKS	00-2010 Accounts Payable	122.48	1,111.56
12/15/2019	Bill	693-MICROMARKETING LLC	books	00-2010 Accounts Payable	638.78	1,750.34
12/15/2019	Bill	693-MICROMARKETING LLC	BOOKS	00-2010 Accounts Payable	540.16	2,290.50
<b>Total for 70-4601 LIBRARY EXPENSES</b>					<b>\$1,646.42</b>	
<b>Total for 70-4000 Library with subs</b>					<b>\$34,425.28</b>	
80-4000 Streets						
Beginning Balance						
						63.64
<b>Total for 80-4000 Streets</b>						
80-4001 Streets-Salaries & Wages						
Beginning Balance						
						65,165.40
12/06/2019	Expense	PAYROLL & BENEFIT SOLUTIONS LLC (PBS)		00-1122 General Fund Checking Accounts:Payroll Acct-Servis 1st-1427	17,920.20	83,085.60
12/20/2019	Expense	PAYROLL & BENEFIT SOLUTIONS LLC (PBS)		00-1122 General Fund Checking Accounts:Payroll Acct-Servis 1st-1427	16,771.01	99,856.61

DATE	TRANSACTION NAME	MEMO/DESCRIPTION	SPLIT	AMOUNT	BALANCE
239	TYPE				
<b>Total for 80-4001 Streets-Salaries &amp; Wages</b>				<b>\$34,691.21</b>	
80-4002 Streets-Payroll Taxes					
Beginning Balance					
					4,920.81
12/06/2019	Expense	PAYROLL & BENEFIT SOLUTIONS LLC (PBS)	00-1122 General Fund Checking Accounts:Payroll Acct-Servis 1st-1427	1,356.27	6,277.08
12/20/2019	Expense	PAYROLL & BENEFIT SOLUTIONS LLC (PBS)	00-1122 General Fund Checking Accounts:Payroll Acct-Servis 1st-1427	1,267.34	7,544.42
<b>Total for 80-4002 Streets-Payroll Taxes</b>				<b>\$2,623.61</b>	
80-4004 Streets-Health Insurance					
Beginning Balance					
					12,428.00
12/06/2019	Expense	PAYROLL & BENEFIT SOLUTIONS LLC (PBS)	00-1122 General Fund Checking Accounts:Payroll Acct-Servis 1st-1427	-221.75	12,206.25
12/15/2019	Bill	2601-LOCAL GOVERNMENT HEALTH INSURANCE BOARD	00-2010 Accounts Payable	7,232.00	19,438.25
12/20/2019	Expense	PAYROLL & BENEFIT SOLUTIONS LLC (PBS)	00-1122 General Fund Checking Accounts:Payroll Acct-Servis 1st-1427	-221.75	19,216.50
<b>Total for 80-4004 Streets-Health Insurance</b>				<b>\$6,788.50</b>	
80-4006 Streets-Retirement					
Beginning Balance					
					4,082.74
12/06/2019	Expense	851- Retirement Systems of Alabama	00-1114 General Fund Checking Accounts:Gen'l Fund-Servis 1st-4304	1,017.20	5,099.94
12/19/2019	Expense	851- Retirement Systems of Alabama	00-1114 General Fund Checking Accounts:Gen'l Fund-Servis 1st-4304	1,008.61	6,108.55
<b>Total for 80-4006 Streets-Retirement</b>				<b>\$2,025.81</b>	
80-4012 Streets-Uniforms					
Beginning Balance					
					590.80
12/15/2019	Bill	3119-CARD SERVICES (8365)	00-2010 Accounts Payable	124.95	715.75
<b>Total for 80-4012 Streets-Uniforms</b>				<b>\$124.95</b>	
80-4015 Streets-Ee Life & Disability Ins					
Beginning Balance					
					476.05
12/30/2019	Bill	2725b-MUTUAL OF OMAHA	00-2010 Accounts Payable	81.75	557.80
<b>Total for 80-4015 Streets-Ee Life &amp; Disability Ins</b>				<b>\$81.75</b>	
80-4018 Streets-Employment Expense					
Beginning Balance					
					230.00
12/15/2019	Bill	3119-CARD SERVICES (8365)	00-2010 Accounts Payable	40.00	270.00
<b>Total for 80-4018 Streets-Employment Expense</b>				<b>\$40.00</b>	
80-4200 Streets-Electrical Utilities					
Beginning Balance					
					1,058.50
12/30/2019	Bill	111-ALABAMA POWER	90002-63006	317.86	1,376.36
<b>Total for 80-4200 Streets-Electrical Utilities</b>				<b>\$317.86</b>	
80-4202 Streets-Telephone					
Beginning Balance					
					183.48
12/15/2019	Bill	3119-CARD SERVICES (8365)	00-2010 Accounts Payable	183.66	367.14
<b>Total for 80-4202 Streets-Telephone</b>				<b>\$183.66</b>	
80-4203 Streets-Cell / Wireless Services					
Beginning Balance					
					105.86
12/15/2019	Bill	3119-CARD SERVICES (8365)	00-2010 Accounts Payable	105.93	211.79
<b>Total for 80-4203 Streets-Cell / Wireless Services</b>				<b>\$105.93</b>	
80-4204 Streets-Gas Utilities					
Beginning Balance					
					127.98
<b>Total for 80-4204 Streets-Gas Utilities</b>					
80-4206 Streets-Water Utilities					
Beginning Balance					
					228.92
12/15/2019	Bill	3119-CARD SERVICES (8365)	00-2010 Accounts Payable	225.32	454.24
<b>Total for 80-4206 Streets-Water Utilities</b>				<b>\$225.32</b>	
80-4208 Streets-Sewer Utilities					
Beginning Balance					
					106.73

DATE	TRANSACTION NAME	MEMO/DESCRIPTION	SPLIT	AMOUNT	BALANCE
240 12/15/2019	Bill 3119-CARD SERVICES (8365)		00-2010 Accounts Payable	359.20	465.93
<b>Total for 80-4208 Streets-Sewer Utilities</b>				<b>\$359.20</b>	
80-4304 Streets-Copier & Printer Mtc					
Beginning					2.85
Balance					
<b>Total for 80-4304 Streets-Copier &amp; Printer Mtc</b>					
80-4306 Streets-Department Supplies					
Beginning					4,341.18
Balance					
12/15/2019	Bill	3119-CARD SERVICES (8365)	00-2010 Accounts Payable	658.05	4,999.23
<b>Total for 80-4306 Streets-Department Supplies</b>				<b>\$658.05</b>	
80-4400 Streets-Contract Services					
Beginning					3,254.81
Balance					
12/15/2019	Bill	3119-CARD SERVICES (8365)	00-2010 Accounts Payable	3,889.75	7,144.56
12/15/2019	Bill	HYDROPHOBIA	POWER WASH OF TRAIN TRESTLE ON ASHVILLE ROAD	875.00	8,019.56
<b>Total for 80-4400 Streets-Contract Services</b>				<b>\$4,764.75</b>	
80-4500 Streets-Repair & Maint Auto					
Beginning					338.68
Balance					
12/15/2019	Bill	3119-CARD SERVICES (8365)	00-2010 Accounts Payable	167.39	506.07
<b>Total for 80-4500 Streets-Repair &amp; Maint Auto</b>				<b>\$167.39</b>	
80-4508 Streets-Repair & MTC - Building					
Beginning					344.37
Balance					
12/15/2019	Bill	637-LOWE'S	SUPPIES	7.95	352.32
<b>Total for 80-4508 Streets-Repair &amp; MTC - Building</b>				<b>\$7.95</b>	
80-4510 Streets-Repair & MTC - Streets					
Beginning					2,407.66
Balance					
12/15/2019	Bill	3119-CARD SERVICES (8365)	00-2010 Accounts Payable	2,227.91	4,635.57
12/30/2019	Bill	985-STONE & SONS ELECTRICAL CONTRACTORS INC	BUCKET TRUCK, TRAFFIC TECH	370.66	5,006.23
12/30/2019	Bill	985-STONE & SONS ELECTRICAL CONTRACTORS INC		441.50	5,447.73
12/30/2019	Bill	985-STONE & SONS ELECTRICAL CONTRACTORS INC	BUCKET TRUCK , TRAFFIC TECH	284.13	5,731.86
<b>Total for 80-4510 Streets-Repair &amp; MTC - Streets</b>				<b>\$3,324.20</b>	
80-4516 Streets-Repair & MTC - Grounds					
Beginning					19.99
Balance					
<b>Total for 80-4516 Streets-Repair &amp; MTC - Grounds</b>					
80-4520 Streets-Fuel Expense - Auto					
Beginning					3,097.97
Balance					
12/30/2019	Bill	1770-WEX BANK	PUBLIC WORKS	1,262.80	4,360.77
<b>Total for 80-4520 Streets-Fuel Expense - Auto</b>				<b>\$1,262.80</b>	
80-4530 Streets-Department Tools					
Beginning					919.30
Balance					
12/15/2019	Bill	3119-CARD SERVICES (8365)	00-2010 Accounts Payable	312.76	1,232.06
<b>Total for 80-4530 Streets-Department Tools</b>				<b>\$312.76</b>	
80-4604 Streets-Equipment Rent/Lease					
Beginning					148.45
Balance					
12/15/2019	Bill	3119-CARD SERVICES (8365)	00-2010 Accounts Payable	152.49	300.94
<b>Total for 80-4604 Streets-Equipment Rent/Lease</b>				<b>\$152.49</b>	
80-6704 Streets-Asset Purchase					
Beginning					74,000.00
Balance					
12/10/2019	Bill	DONOHOO CHEVROLET LLC	2020 CHEV TAHOE - 1GNLCDEC1LR198318	26,000.00	100,000.00
<b>Total for 80-6704 Streets-Asset Purchase</b>				<b>\$26,000.00</b>	
<b>Total for 80-4000 Streets with subs</b>				<b>\$84,218.19</b>	
83-4000 Solid Waste Exp					
83-4210 Solid Waste-Disposal Fee					
Beginning					7,209.24
Balance					
12/15/2019	Bill	3119-CARD SERVICES (8365)	00-2010 Accounts Payable	6,699.48	13,908.72
<b>Total for 83-4210 Solid Waste-Disposal Fee</b>				<b>\$6,699.48</b>	
83-4300 Solid Waste-Department Supplies					
Beginning					180.00



DATE	TRANSACTION NAME	MEMO/DESCRIPTION	SPLIT	AMOUNT	BALANCE
241	TYPE				
Balance					
<b>Total for 83-4300 Solid Waste-Department Supplies</b>					
83-4502 Solid Waste-Repair & MTC -Auto					
Beginning					
					1,583.96
Balance					
12/15/2019	Bill	3119-CARD SERVICES (8365)	00-2010 Accounts Payable	1,324.30	2,908.26
<b>Total for 83-4502 Solid Waste-Repair &amp; MTC -Auto</b>					
				<b>\$1,324.30</b>	
83-4520 Solid Waste-Fuel Expense-Solid Waste					
Beginning					
					2,871.43
Balance					
12/30/2019	Bill	1770-WEX BANK	00-2010 Accounts Payable	1,041.15	3,912.58
<b>Total for 83-4520 Solid Waste-Fuel Expense-Solid Waste</b>					
				<b>\$1,041.15</b>	
<b>Total for 83-4000 Solid Waste Exp</b>					
				<b>\$9,064.93</b>	

City of Leeds-Debt Service

EXPENSE DETAIL

December 2019

DATE	TRANSACTION TYPE	NUM	ADJ	NAME	MEMO/DESCRIPTION	SPLIT	AMOUNT	BALANCE
09-4716 PLEDGED REVENUES								
	Beginning Balance							451,728.76
12/15/2019	Bill	Debt Dec 2019	No	3151-REGIONS CORPORATE TRUST	LEEDS TAXABLE GENERAL OBLIGATION SERIES 2018 WARRANTS	Accounts Payable (A/P)	225,864.38	677,593.14
<b>Total for 09-4716 PLEDGED REVENUES</b>							<b>\$225,864.38</b>	
09-6100 BOND FEES								
	Beginning Balance							5,701.88
<b>Total for 09-6100 BOND FEES</b>								
09-6200 GEN OBLIG PRINCIPAL RET								
	Beginning Balance							41,461.97
12/15/2019	Bill	DEBT-DEC2019	No	3152-REGIONS CORPORATE TRUST	LEEDS GENERAL OBLIGATION SERIES 2017A WARRANTS	Accounts Payable (A/P)	21,666.67	63,128.64
<b>Total for 09-6200 GEN OBLIG PRINCIPAL RET</b>							<b>\$21,666.67</b>	
09-6202 GEN OBLIG INTEREST								
	Beginning Balance							23,305.72
12/15/2019	Bill	DEBT-DEC2019	No	3152-REGIONS CORPORATE TRUST	LEEDS GENERAL OBLIGATION SERIES 2017A WARRANTS	Accounts Payable (A/P)	12,167.71	35,473.43
<b>Total for 09-6202 GEN OBLIG INTEREST</b>							<b>\$12,167.71</b>	
09-6999 Account Transfer								
	Beginning Balance							-58,384.03
<b>Total for 09-6999 Account Transfer</b>								
19-6507 19-6507 Primary School Constr.- Long Term Debt								
	Beginning Balance							66,666.66
12/15/2019	Bill	DEBT-DEC2019	No	68- REGIONS CORPORATE TRUST	Primary School Constr.- Long Term Debt	Accounts Payable (A/P)	33,750.00	100,416.66
<b>Total for 19-6507 19-6507 Primary School Constr.- Long Term Debt</b>							<b>\$33,750.00</b>	
19-6508 19-6508 Primary School Constr.-Long Term Interest								
	Beginning Balance							70,946.88
12/15/2019	Bill	DEBT-DEC2019	No	68- REGIONS CORPORATE TRUST	LESS EXCESS FUNDS	Accounts Payable (A/P)	-5,741.64	65,205.24
12/15/2019	Bill	DEBT-DEC2019	No	68- REGIONS CORPORATE TRUST	Primary School Constr.-Long Term Interest	Accounts Payable (A/P)	34,473.44	99,678.68
<b>Total for 19-6508 19-6508 Primary School Constr.-Long Term Interest</b>							<b>\$28,731.80</b>	
26-6300 26-6300 Fire-Long Term Debt-Fire Truck								
	Beginning Balance							47,093.29
<b>Total for 26-6300 26-6300 Fire-Long Term Debt-Fire Truck</b>								
40-6300 40-6300 Parks Long Term Debt Prin Retirement								
	Beginning Balance							32,571.16
12/15/2019	Bill	DEVT DEC 2019	No	3153-REGIONS CORPORATE TRUST	LEEDS GENERAL OBLIGATION SERIES 2017B WARRANTS	Accounts Payable (A/P)	16,916.35	49,487.51
<b>Total for 40-6300 40-6300 Parks Long Term Debt Prin Retirement</b>							<b>\$16,916.35</b>	

# City of Leeds-Gas Taxes

EXPENSE DETAIL  
December 2019

DATE	TRANSACTION TYPE	NUM	ADJ	NAME	MEMO/DESCRIPTION	SPLIT	AMOUNT	BALANCE
07-4000 Seven Cent Expenses								
07-4200 ELECTRICAL UTILITIES								
Beginning Balance								26,831.98
12/30/2019	Bill	7C-SB05315-78097	No	111-ALABAMA POWER	STREETLIGHTS	Accounts Payable (A/P)	13,425.84	40,257.82
<b>Total for 07-4200 ELECTRICAL UTILITIES</b>							<b>\$13,425.84</b>	
07-4510 7 CT RPR & MTC - STREETS								
Beginning Balance								49,988.42
<b>Total for 07-4510 7 CT RPR &amp; MTC - STREETS</b>								
<b>Total for 07-4000 Seven Cent Expenses</b>							<b>\$13,425.84</b>	

**Item Attachment Documents:**

26. Consider 2020-01-05 Consider Budget Amendments - City Projects

# CITY OF LEEDS

## RESOLUTION NO.: 2020-01-05

### RESOLUTION APPROVING AND AUTHORIZING BUDGET ADJUSTMENTS AND AMENDMENTS AND RELATED EXPENDITURES

**WHEREAS**, certain unanticipated expenditures in relation to the Administration, Finance, Council, and Civic Center accounts have been identified as set forth herein; and

**WHEREAS**, the projects and expenditures were not previously anticipated or provided for in the City’s 2019-2020 budget; and

**WHEREAS**, in order for these projects to be completed within the current fiscal year, the City Council would have to authorize the projects and the anticipated cost for said projects which would result in a reduction in the general fund balance.

**NOW THEREFORE, BE IT RESOLVED**, by the City Council of the City of Leeds that:

1. The Recitals above are true, correct, and included herein as if fully set forth.
2. The budget amendment requests as set forth in the itemized list below are hereby authorized and approved in the amounts as set forth and to be expended from the City reserve account.

Item	Category	Cost Estimate
Administration – Annex Building Modifications	Budget Amendment	\$60,000.00
Public Works Christmas Decorations	Budget Amendment	\$40,000.00

3. The Mayor and staff shall have the full authority to do those things, perform those functions, make such decisions, and to sign necessary documentation in order to carry out and fully complete the actions so authorized herein.

**ADOPTED and APPROVED** this the 6<sup>th</sup> day of January 2020.

CITY OF LEEDS, ALABAMA:

\_\_\_\_\_  
David Miller, Mayor

\_\_\_\_\_  
Date

**AYES:** \_\_\_\_\_

**NAYS:** \_\_\_\_\_

**ABSENT FROM VOTING:** \_\_\_\_\_

**ABSTAIN:** \_\_\_\_\_

ATTEST:

---

Toushi Arbitelle, City Clerk

I, Toushi Arbitelle, City Clerk of the City of Leeds, hereby certify that the above Resolution was duly adopted by the City Council of the City of Leeds at a regular meeting held on the 6<sup>th</sup> day of January 2020.

---

**City Clerk**

**Item Attachment Documents:**

27. Resolution 2020-01-06 Consider Tax Abatement Agreement with Hubbell Power Systems Inc. at 1612 Moores Street



ALABAMA DEPARTMENT OF REVENUE
Application to Granting Authority
for Abatement of Taxes

Under Chapter 9B, Title 40, Code of Alabama 1975

Noneducational Sales and Use Taxes, Noneducational Property Taxes, and/or Mortgage and Recording Taxes

This form is to be submitted to the granting authority for consideration in granting an abatement of all state and local noneducational property taxes, all construction related transaction (sales and use) taxes, except those local construction related transaction taxes levied for educational purposes or for capital improvements for education, and/or mortgage and recording fees, in accordance with the provisions of Section 40-9B-1 et seq., Code of Alabama 1975.

1a. TYPE OF ABATEMENT APPLYING FOR: [X] Sales & Use Taxes [X] Property Taxes [ ] Mortgage & Recording Taxes
2. PROJECT NAICS CODE: [3][3][3][6][1][3]

1b. IS APPLICANT REQUESTING PROPERTY TAX ABATEMENT FOR A PERIOD LONGER THAN 10 YEARS? [ ] Yes [X] No
3. TYPE OF PROJECT: [ ] New Project [X] Major Addition To An Existing Facility

4. DOES MAJOR ADDITION EQUAL THE LESSER OF: (CHECK APPLICABLE BOX)
[ ] \$2,000,000 - OR - [ ] 30% of original cost of existing property, original cost \$

5. PROJECT APPLICANT: Hubbell Power Systems, Inc. DBA: Hubbell Power Systems, Inc.

6. ADDRESS OF APPLICANT: 40 Waterview Drive CITY: Shelton STATE: CT ZIP CODE: 06484

7. NAME OF CONTACT PERSON: Ben Gossart EMAIL ADDRESS: bgossart@hubbell.com TELEPHONE NUMBER: ( 475 ) 882-4277

8. DATE COMPANY ORGANIZED: 3/18/1994

9. PHYSICAL LOCATION OF PROJECT: 1612 Moores Street

CITY (IF OUTSIDE CITY LIMITS, PLEASE INDICATE): Leeds COUNTY: Jefferson ZIP CODE: 35094

10. BRIEF DESCRIPTION OF PROJECT (ATTACH A COMPLETE AND DETAILED LISTING OF PROJECT PROPERTY COSTS TO ENABLE A COST/BENEFIT ANALYSIS BY GRANTING AUTHORITY): See attached for detailed project description

11. ESTIMATED DATE CONSTRUCTION WILL BEGIN: August 2019
12. ESTIMATED DATE CONSTRUCTION WILL BE COMPLETED: July 2022
13. ESTIMATED DATE PROPERTY WILL BE PLACED IN SERVICE: Various

14. HAVE BONDS BEEN ISSUED FOR PROJECT: [ ] No [ ] Yes If yes, date bonds issued:
15. WILL BONDS BE ISSUED FOR PROJECT [X] No [ ] Yes If yes, projected date of issue:

Table with 5 columns: 16. ESTIMATED NUMBER OF NEW EMPLOYEES, 17. ESTIMATED ANNUAL PAYROLL OF NEW EMPLOYEES, Estimated Investment for Project, 18. COST OR VALUE FOR PROPERTY TAX, 19. COST SUBJECT TO SALES TAX. Rows include Land, Existing Building(s), Existing Personal Property, New Building(s), and Totals.

The abatement of noneducational property taxes is based on the market value of specific assets; therefore, the actual amount of taxes abated is determined each year as the property is assessed and valued. An abatement of noneducational sales and use taxes shall apply only to tangible personal property and taxable services incorporated into private use industrial property, the cost of which may be added to capital account with respect to the property, determined without regard to any rule which permits expenditures properly chargeable to capital account to be treated as current expenses.

I hereby affirm that, to the best of my knowledge and belief, the information in this application and any accompanying statement, schedules, and other information is true, correct and complete.

Anne Boyd
NAME (PRINT)

Vice President & Assistant Treasurer
SIGNATURE TITLE DATE



## Instructions for Preparing Application to Granting Authority for Abatement of Taxes (Form CO: CAA)

Under Chapter 9B of Title 40, *Code of Alabama 1975*

### GENERAL INSTRUCTIONS

Chapter 9B, Title 40, *Code of Alabama 1975*, provides for an abatement of all state and local noneducational property taxes, all construction related transaction taxes (sales and use taxes), except those local construction related transaction taxes levied for educational purposes or for capital improvements for education, and/or all mortgage and recording taxes relating to mortgages, deeds, and documents used to issue or secure obligations and convey title into or out of the name of a public authority, county or municipal government.

This form is to be submitted to the granting authority for consideration in granting an abatement of noneducational sales and use taxes, noneducational property taxes, and/or mortgage and recording taxes. **If you have any questions about this form or the abatement of taxes in general, please contact the Alabama Department of Revenue at (334) 242-1175.**

**A complete and detailed listing of project costs should be attached to this application in order for the granting authority to make a cost/benefit analysis in accordance with Section 40-9B-6(a).**

### STATUTORY REQUIREMENTS FOR ABATEMENTS

The following are qualifying business activities under Section 40-9B-3, *Code of Alabama 1975*:

- Industrial or Research Enterprise – Any trade or business in the 2007 North American Industrial Classification System (NAICS), promulgated by the Executive Office of the President of the United States, Office of Management and Budget as: Sectors 31 (except National Industry 311811), 32, 33, 55 (if not for the production of electricity), Subsectors 423, 424, 482, 493, 511, 517, 518, 927, Industry Groups 1133, 2121, 4862, 4882, 4883 (other than 48833) 5121 (other than 51213), 5415, 5417, Industries 22111, 48691, 48699, 48819, 51221, 51913, 52232, 54133, 54134, 54138, 56291, 56292, 92811, National Industries 115111, 221330, 541614, 561422 (in bound call centers only), 562213, and 611512.
- Subsector 493, Industry Number 488310, or 488320 when such trade or business is conducted on premises in which the Alabama State Port Authority has an ownership, leasehold, or other possessory interest and such premises are used as part of the operations of the Alabama State Port Authority. These projects require written approval of the Governor, Finance Director, and the Director of the Alabama State Port Authority.
- Headquarters Facility – Any trade or business in the 2007 North American Industrial Classification System (NAICS), promulgated by the Executive Office of the President of the United States, Office of Management and Budget as National Industry 551114 at which at least 50 new jobs are located.
- Data Processing Center – An establishment, at which at least 20 new jobs are located, engaged in the provision of complete processing and specialized reports from data, the provision of automated data processing and data entry services, the provision of an infrastructure for hosting or data processing services, the provision of specialized hosting activities, the provision of application service provisioning, the provision of general time-share mainframe facilities, or some combination of the foregoing, without regard to whether any other activities are conducted at the establishment.
- Research & Development Facility – An establishment engaged in conducting original investigations undertaken on a systematic basis to gain new knowledge and/or applying research findings or other scientific knowledge to create new or significantly improved products or processes.
- Renewable Energy Facility – Any plant, property, or facility that either:
  1. Produces electricity or natural gas, in whole or in part, from biofuels as such term is defined in Section 2-2-90(c)(2) or from renewable energy resources as such term is defined in Section 40-18-1(30) with the exception that hydropower production shall be excluded from such definition; or
  2. Produces biofuel as such term is defined in Section 2-2-90(c)(2).
- Alternative Energy Resources Electricity Production Project - A project owned by a utility described in Section 37-4-1(7)a, Code of Alabama 1975, or owned by a company which is itself owned by a utility, at which the predominant trade or business activity conducted will be the production of electricity from alternative energy resources (coal gasification or liquefaction, nuclear and/or advanced fossil-based generation), the capital costs of which are not less than \$100,000,000.
- Hydropower Electricity Production Project - A project owned by a utility described in Section 37-4-1(7)a, or owned by a company which is itself owned by a utility, at which the predominant trade or business activity conducted will be the production of electricity from hydropower production as defined in Section 40-18-1(16), the capital costs of which are not less than \$5,000,000.
- Tourist Destination Attractions – A commercial enterprise which is open to the public not less than 120 days during a calendar year and is designed to attract visitors from inside or outside of the State of Alabama, typically for its inherent cultural value, historical significance, natural or man-made beauty, or entertainment or amusement opportunities. The term shall include, but not be limited to, a cultural or historical site; a botanical garden; a museum; a wildlife park or aquarium open to the public that cares for and displays a collection of animals or fish; an amusement park; a convention hotel and conference center; a water park; or a spectator venue or arena.
- Any of the 11 targeted business sectors under the Accelerate Alabama Strategic Economic Development Plan adopted in January 2012 by the Alabama Economic Development Alliance, created by Executive Order Number 21 of the Governor on July 18, 2011, which include Advanced Manufacturing in Aerospace/Defense, Automotive, Agricultural Products/Food Production, Steel/Metal, Forestry Products and Chemicals; Technology in Biosciences, Information Technology, Enabling Technologies; Distribution/Logistics and Corporate Operations.

## LINE BY LINE INSTRUCTIONS

**Item 1a.** Indicate the type(s) of abatement(s) being requested.

**Sales and Use Taxes** – Chapter 9B, Title 40, *Code of Alabama 1975*, provides for the abatement of certain noneducational sales and use taxes imposed by Chapter 23 of Title 40, *Code of Alabama 1975*. The abatement applies to the tangible personal property and taxable services incorporated into the project, the cost of which may be added to the capital account with respect to the project. However, only the state and local noneducational sales and use taxes may be abated. No sales and use tax abatement shall extend beyond the date the project is placed in service.

**Property Taxes** – Chapter 9B, Title 40, *Code of Alabama 1975*, provides for the abatement of noneducational property taxes imposed by the state, counties, municipalities and other taxing jurisdictions in Alabama. Only industrial property not previously placed in service in Alabama by the user or a related party may be eligible for an abatement of noneducational property taxes.

**Mortgage And Recording Taxes** – Chapter 9B, Title 40, *Code of Alabama 1975*, provides for the abatement of all taxes imposed by Chapter 22 of Title 40 of the *Code of Alabama 1975*, relating to mortgages, deeds, and documents used to issue or secure obligations and convey title into or out of the name of a public authority.

**Item 1b.** Indicate if applicant is requesting abatement of property taxes for a period longer than 10 years. For any property tax abatement that is granted for over 10 years, the noneducational municipal taxes can only be abated by the City Government, noneducational county taxes can only be abated by the County Government, and state taxes can only be abated by the Governor. The governing body of the municipality and county can authorize a public industrial authority to provide by resolution for such consent on its behalf.

**Item 2.** If the predominant business activity is a headquarters facility, an industrial or research enterprise as defined in *Code of Alabama 1975* Section 40-9B-3(10)(a) or a state docks project as defined in Section 40-9B-3(10)(b), enter the 2007 North American Industrial Classification System (NAICS) code for the project.

**Item 3.** Indicate if project is a new project or a major addition.

**New Project** – Any new business in Alabama at which the predominant trade or business activity conducted will constitute an industrial or research enterprise or other qualifying business activity as described above. If new project, skip Item 4.

**Major Addition** – Pursuant to Section 40-9B-3(11), a major addition is an addition to an existing facility in which the addition equals the lesser of thirty (30) percent of the original cost of the existing land, buildings, and equipment (industrial development property), or \$2,000,000, and at which the predominant trade or business activity conducted in Alabama will constitute an industrial or research enterprise or other qualifying business activity as described above. Capitalized repairs, rebuilds, maintenance, replacement equipment, or costs associated with the renovating or remodeling of existing facilities of industrial development property previously placed in service in Alabama by the Company are not eligible for abatement under Chapter 9B.

**Item 4.** Indicate if major addition is in accordance with Section 40-9B-3(11) requirement as denoted above. If major addition does not meet threshold requirement, project is not qualified to receive abatement. Original cost should include the total cost of existing facilities as of the date of application.

**Item 5.** Enter the name of the private user requesting abatement. If project is doing business under another name, also enter the name of the company under "Doing Business As (DBA)."

**Item 6.** Enter the address of the private user requesting abatement.

**Item 7.** Enter the name, email address and telephone number of the person to which all correspondence should be directed regarding the abatement.

**Item 8.** Enter the date the company was organized.

**Item 9.** Enter the physical location of the project. Please include a detailed location, including the City, County and Zip Code.

**Item 10.** Describe the type of business that the project will be engaged in. For projects that do not require a NAICS code, provide a detailed description that will identify the activities as qualifying activities. Attach additional sheets if necessary.

**Item 11.** Enter the estimated date the construction of the project will begin.

**Item 12.** Enter the estimated date the construction of the project will be completed. A data processing center project's completion date will be the maximum exemption period allowed pursuant to Section 40-9B-3(12)b.

**Item 13.** Enter the estimated date the project will be placed in service. If revenue bonds are issued, "placed in service," for property tax purposes, is determined as of the date of the initial issuance of such bonds. Otherwise, with the exception of a data processing center project, "placed in service" for sales and use tax and property tax purposes is determined as the later of 1) the date on which title to the property was acquired by or vested in a county, city, or public authority, or 2) the date on which the property is or becomes owned, for federal income tax purposes, by a private user. A data processing center project's placed in service date will be the maximum exemption period allowed pursuant to Section 40-9B-3(12)b.

**Item 14.** Indicate if bonds have been issued in financing the project. If bonds have been issued, enter the issuance date.

**Item 15.** Indicate if bonds will be issued for financing the project. If bonds will be issued, enter the projected issuance date.

**Column 16.** Enter the estimated number of new employees to be hired at the project. The law requires the number of employees to be employed at the project initially and in each of the succeeding three years.

**Column 17.** Enter the estimated annual payroll for employees at the project. The law requires the estimated payroll of new employees initially and in each of the succeeding three years.

**Column 18.**

**18a.** Enter all costs or value for project land. If land is donated, enter the market value of the land.

**18b.** Enter all costs or value for existing building(s), if any.

**18c.** Enter all costs or value for existing personal property to be incorporated into project. Only personal property not previously placed in service in Alabama by the private user or a related party can be included. If a private user is including existing equipment from outside of Alabama, the existing equipment should be entered here at its original cost.

**18d.** Enter the total cost for new building(s) and/or new additions to existing building(s). Total cost includes building materials, construction costs, engineering costs, etc. Costs associated with renovating or remodeling existing facilities of an operating industrial or research enterprise do not qualify for abatement.

**18e.** Enter the total cost for new manufacturing equipment to be incorporated into the project. Replacement equipment does not qualify for abate-

er Chapter 9B. New equipment that is defined as upgraded equipment qualify. Upgraded equipment is equipment that replaces existing equipment, and performs not only the same functions, but also an additional function.

**18f.** Enter the total cost for all other new personal property. Other new personal property may include, but is not limited to, non-manufacturing machinery, office equipment, computers, vehicles, etc. Only personal property that is a depreciable item can be included.

**18g.** Add 18a through 18f and enter total here. This is the total amount on which the initial property taxes will be based. This total must be the total value of the cost or investment in the project. This total must agree with the total investment amount in the abatement resolution and the total investment amount in the abatement agreement.

**Column 19.**

**19d.** Enter the cost of the building materials (subject to sales tax) that become a part of realty for new building(s) and/or new additions to existing building(s). Other building costs (labor, engineering) are not subject to sales tax.

**19e.** Enter the cost of new manufacturing equipment for the project. For sales tax purposes, manufacturing equipment is taxed at a lower rate. Equipment that is purchased used from another company in an isolated transaction is not subject to sales tax and should not be included.

**19f.** Enter the cost of all other new personal property.

**19g.** Add 19d through 19f and enter total here.

# CITY OF LEEDS

## RESOLUTION NO.: 2020-01-06

### IN REGARDS TO THE CONSIDERATION OF A TAX ABATEMENT AGREEMENT WITH THE HUBBELL, Inc. -Moore's St. - Plant ("Hubbell" or the "Company") within the City of Leeds, Alabama.

**WHEREAS**, the Company has announced plans for a new business expansion project, located within the jurisdiction of the City of Leeds; and

**WHEREAS**, pursuant to the Tax incentive Reform Act of 1992 (Section 40-9B-1 et se q., Code of Alabama 1975) (the Act), the Company has requested from the City of Leeds an Abatement of:

- all state and local non-educational property taxes,
- all construction related transaction taxes, except those construction related transaction taxes;
- levied for educational purposes or for capital improvements for education, and/or
- all mortgage and recoding taxes; and

**WHEREAS**, the City of Leeds has considered the request of the Company and the completed applications (copy attached) filed with the City of Leeds by the Company, in connection with its request; and

**WHEREAS**, the City of Leeds has found the information contained in the Company's application to be enough to permit the City of Leeds to make a reasonable cost/benefit analysis of the proposed project and to determine the economic benefits to the community; and

**WHEREAS**, the construction of the project will involve a capital investment of \$;2,025,000.00 and

**WHEREAS**, the Company is duly qualified to do business in the State of Alabama, and has powers to enter into, and to perform and observe the agreements and covenants on its part contained in the Tax Abatement Agreement;and

**WHEREAS**, the City of Leeds represents and warrants to the Company that it has power under that constitution and laws of the State of Alabama (including particularly the provisions of the Act) to carry out provisions of the Tax Abatement Agreement;

**WHEREAS**, the company is required to hire 30% of the newly created jobs associated with this tax abatement to be residents of the City of Leeds;

**NOW THEREFORE, BE IT RESOLVED** by the City of Leeds as follows:

1) Approval is hereby given to the application of the Company and abatement is hereby granted of:

- X   all state and local non-educational property taxes,
- X   all construction related transaction taxes, except those construction related transaction
- taxes levied for educational purposes or for capital improvements for education, and/or
- all mortgage and recoding taxes; and

as the same may apply to the fullest extent permitted by the Act. The period of abatement for the non-educational property taxes (if applicable) shall extend for a period of **ten (10) years** measured as provided in Section 40-9B-3(8) of the Act.

- 2) The City of Leeds is authorized to enter into an abatement agreement, in substantially the same form as attached hereto, with the Company to provide for the abatement granted in Section 1.
- 3) A certified copy of this resolution, with the application and abatement agreement, shall be forwarded to the Company to deliver to the appropriate local taxing authorities (if applicable) and to the Alabama Department of Revenue in accordance with the Act.
- 4) The City of Leeds is authorized to take any and all actions necessary or desirable to accomplish the purpose of the foregoing of this resolution.

**BE IT FURTHER RESOLVED** that the Mayor and staff shall have the full authority to do those things, perform those functions, and to sign necessary documentation in order to carry out and complete the actions so authorized herein.

**BE IT FURTHER RESOLVED,** that the provisions of this Resolution are severable. If any part of this Resolution is determined by a court of law to be invalid, unenforceable or unconstitutional, such determination shall not affect any other part of this Resolution.

**AYES:** \_\_\_\_\_

**NAYS:** \_\_\_\_\_

**ABSENT FROM VOTING:** \_\_\_\_\_

**ABSTAIN:** \_\_\_\_\_

**CITY OF LEEDS, ALABAMA**

\_\_\_\_\_  
**David Miller, Mayor**

\_\_\_\_\_  
**Date**

**ATTEST:**

\_\_\_\_\_  
**Toushi Arbitelle, City Clerk**

I, Toushi Arbitelle, City Clerk of the City of Leeds, hereby certify that the above Resolution was duly adopted by the City Council of the City of Leeds at a regular meeting held on the 6<sup>th</sup> day of January 2020.

\_\_\_\_\_  
City Clerk

**Item Attachment Documents:**

28. Resolution 2020-01-07 Consider Tax Abatement Agreement with Hubbell Power Systems Inc. at 8100 Churchill Avenue

# CITY OF LEEDS

## RESOLUTION NO.: 2020-01-07

### IN REGARD TO THE CONSIDERATION OF A TAX ABATEMENT AGREEMENT WITH THE HUBBELL, Inc. -CHURCHILL AVE PLANT ("Hubbell" or the "Company") within the City of Leeds, Alabama.

**WHEREAS**, the Company has announced plans for a new business expansion project, located within the jurisdiction of the City of Leeds; and

**WHEREAS**, pursuant to the Tax incentive Reform Act of 1992 (Section 40-9B-1 et se q., Code of Alabama 1975) (the Act), the Company has requested from the City of Leeds an Abatement of:

- all state and local non-educational property taxes,
- all construction related transaction taxes, except those construction related transaction taxes;
- levied for educational purposes or for capital improvements for education, and/or
- all mortgage and recoding taxes; and

**WHEREAS**, the City of Leeds has considered the request of the Company and the completed applications (copy attached) filed with the City of Leeds by the Company, in connection with its request; and

**WHEREAS**, the City of Leeds has found the information contained in the Company's application to be enough to permit the City of Leeds to make a reasonable cost/benefit analysis of the proposed project and to determine the economic benefits to the community; and

**WHEREAS**, the construction of the project will involve a capital investment of \$; 17,254.000.00 and

**WHEREAS**, the Company is duly qualified to do business in the State of Alabama, and has powers to enter into, and to perform and observe the agreements and covenants on its part contained in the Tax Abatement Agreement;and

**WHEREAS**, the City of Leeds represents and warrants to the Company that it has power under that constitution and laws of the State of Alabama (including particularly the provisions of the Act) to carry out provisions of the Tax Abatement Agreement;

**WHEREAS**, the company is required to hire 30% of the newly created jobs associated with this tax abatement to be residents of the City of Leeds in each of the programs years and maintain said employment levels for the entirety of the program;

**WHEREAS**, should the company not meet the hiring targets described herein, the company shall refund 30% of abated taxes back to the City;



**NOW THEREFORE, BE IT RESOLVED** by the City of Leeds as follows:

1) Approval is hereby given to the application of the Company and abatement is hereby granted of:

- X   all state and local non-educational property taxes,
- X   all construction related transaction taxes, except those construction related transaction
- taxes levied for educational purposes or for capital improvements for education, and/or
- all mortgage and recoding taxes; and

as the same may apply to the fullest extent permitted by the Act. The period of abatement for the non-educational property taxes (if applicable) shall extend for a period of **ten (10) years** measured as provided in Section 40-9B-3(8) of the Act.

- 2) The City of Leeds is authorized to enter into an abatement agreement, in substantially the same form as attached hereto, with the Company to provide for the abatement granted in Section 1.
- 3) A certified copy of this resolution, with the application and abatement agreement, shall be forwarded to the Company to deliver to the appropriate local taxing authorities (if applicable) and to the Alabama Department of Revenue in accordance with the Act.
- 4) The City of Leeds is authorized to take any and all actions necessary or desirable to accomplish the purpose of the foregoing of this resolution.

**BE IT FURTHER RESOLVED** that the Mayor and staff shall have the full authority to do those things, perform those functions, and to sign necessary documentation in order to carry out and complete the actions so authorized herein.

**BE IT FURTHER RESOLVED,** that the provisions of this Resolution are severable. If any part of this Resolution is determined by a court of law to be invalid, unenforceable or unconstitutional, such determination shall not affect any other part of this Resolution.

**AYES:** \_\_\_\_\_

**NAYS:** \_\_\_\_\_

**ABSENT FROM VOTING:** \_\_\_\_\_

**ABSTAIN:** \_\_\_\_\_

**CITY OF LEEDS, ALABAMA**

\_\_\_\_\_  
**David Miller, Mayor**

\_\_\_\_\_  
**Date**

**ATTEST:**

\_\_\_\_\_  
**Toushi Arbitelle, City Clerk**

I, Toushi Arbitelle, City Clerk of the City of Leeds, hereby certify that the above Resolution was duly adopted by the City Council of the City of Leeds at a regular meeting held on the 6<sup>th</sup> day of January 2020.

\_\_\_\_\_  
City Clerk



# ALABAMA DEPARTMENT OF REVENUE Application to Granting Authority for Abatement of Taxes

Under Chapter 9B, Title 40, Code of Alabama 1975

## Noneducational Sales and Use Taxes, Noneducational Property Taxes, and/or Mortgage and Recording Taxes

This form is to be submitted to the granting authority for consideration in granting an abatement of all state and local noneducational property taxes, all construction related transaction (sales and use) taxes, except those local construction related transaction taxes levied for educational purposes or for capital improvements for education, and/or mortgage and recording fees, in accordance with the provisions of Section 40-9B-1 et seq., Code of Alabama 1975.

1a. TYPE OF ABATEMENT APPLYING FOR: <input checked="" type="checkbox"/> Sales & Use Taxes <input checked="" type="checkbox"/> Property Taxes <input type="checkbox"/> Mortgage & Recording Taxes	2. PROJECT NAICS CODE: <table border="1"><tr><td>3</td><td>3</td><td>3</td><td>6</td><td>1</td><td>3</td></tr></table>	3	3	3	6	1	3
3	3	3	6	1	3		

1b. IS APPLICANT REQUESTING PROPERTY TAX ABATEMENT FOR A PERIOD LONGER THAN 10 YEARS? <input type="checkbox"/> Yes <input checked="" type="checkbox"/> No	3. TYPE OF PROJECT: <input type="checkbox"/> New Project <input checked="" type="checkbox"/> Major Addition To An Existing Facility
--	--

4. DOES MAJOR ADDITION EQUAL THE LESSER OF: (CHECK APPLICABLE BOX)  
 \$2,000,000 - OR -  30% of original cost of existing property, original cost \$ \_\_\_\_\_

5. PROJECT APPLICANT: Hubbell Power Systems, Inc.	DBA: Hubbell Power Systems, Inc.
--	-------------------------------------

6. ADDRESS OF APPLICANT: 40 Waterview Drive	CITY: Shelton	STATE: CT	ZIP CODE: 06484
--	------------------	--------------	--------------------

7. NAME OF CONTACT PERSON: Ben Gossart	EMAIL ADDRESS: bgossart@hubbell.com	TELEPHONE NUMBER: ( 475 ) 882-4277
---	--	---------------------------------------

8. DATE COMPANY ORGANIZED:  
3/18/1994

9. PHYSICAL LOCATION OF PROJECT:  
8100 Churchill Avenue

CITY (IF OUTSIDE CITY LIMITS, PLEASE INDICATE): Leeds	COUNTY: Jefferson	ZIP CODE: 35094
--	----------------------	--------------------

10. BRIEF DESCRIPTION OF PROJECT (ATTACH A COMPLETE AND DETAILED LISTING OF PROJECT PROPERTY COSTS TO ENABLE A COST/BENEFIT ANALYSIS BY GRANTING AUTHORITY):  
See attached for detailed project description

11. ESTIMATED DATE CONSTRUCTION WILL BEGIN: June 2020	12. ESTIMATED DATE CONSTRUCTION WILL BE COMPLETED: May 2023	13. ESTIMATED DATE PROPERTY WILL BE PLACED IN SERVICE: Various
--	--	---

14. HAVE BONDS BEEN ISSUED FOR PROJECT: <input type="checkbox"/> No <input type="checkbox"/> Yes    If yes, date bonds issued:	15. WILL BONDS BE ISSUED FOR PROJECT <input checked="" type="checkbox"/> No <input type="checkbox"/> Yes    If yes, projected date of issue:
---	---

16. ESTIMATED NUMBER OF NEW EMPLOYEES	17. ESTIMATED ANNUAL PAYROLL OF NEW EMPLOYEES	Estimated Investment for Project	18. COST OR VALUE FOR PROPERTY TAX	19. COST SUBJECT TO SALES TAX
INITIALLY	INITIALLY	a. Land (if donated, show market value) .....	18a	XXXXXXXXXXXX
YEAR 1	YEAR 1	b. Existing Building(s) (if any) .....	18b	XXXXXXXXXXXX
5	\$ 255,827		\$ 0	
YEAR 2	YEAR 2	c. Existing Personal Property (if any) .....	18c	XXXXXXXXXXXX
17	\$ 869,811		\$ 2,250,000	
YEAR 3	YEAR 3	d. New Building(s) and/or New Additions to Existing Building(s) (19d = building materials only) .....	18d	19d
18	\$ 920,976			
This form may be used as the application to the granting authority required by Section 40-9B-6(a), Code of Alabama 1975. The information requested here is required by Section 40-9B-6 and Section 40-2-11(7), Code of Alabama 1975.		e. New Manufacturing Machinery .....	18e	19e
		f. Other New Personal Property (non-mfg machinery, office equipment, computers, etc.) .....	18f	19f
		g. TOTALS (PROPERTY TAX TOTAL MUST EQUAL TOTAL PROJECT INVESTMENT. SALES TAX TOTAL WILL BE LESS.) .....	18g	19g
			\$ 2,025,000	\$ 2,025,000
			\$ 0	\$ 0
			\$ 4,275,000	\$ 2,025,000

The abatement of noneducational property taxes is based on the market value of specific assets; therefore, the actual amount of taxes abated is determined each year as the property is assessed and valued. An abatement of noneducational sales and use taxes shall apply only to tangible personal property and taxable services incorporated into private use industrial property, the cost of which may be added to capital account with respect to the property, determined without regard to any rule which permits expenditures properly chargeable to capital account to be treated as current expenses. No abatement of sales and use taxes shall extend beyond the date private use industrial property is placed in service. A verification inspection of qualifying property will be conducted by the Alabama Department of Revenue to insure compliance with Section 40-9B-1 et seq., Code of Alabama 1975, as amended.

I hereby affirm that, to the best of my knowledge and belief, the information in this application and any accompanying statement, schedules, and other information is true, correct and complete.

Anne Boyd  
 \_\_\_\_\_  
 NAME (PRINT)  
  
 \_\_\_\_\_  
 SIGNATURE

Vice President & Assistant Treasurer  
 \_\_\_\_\_  
 TITLE

9/6/19  
 \_\_\_\_\_  
 DATE

## Instructions for Preparing Application to Granting Authority for Abatement of Taxes (Form CO: CAA)

Under Chapter 9B of Title 40, *Code of Alabama 1975*

### GENERAL INSTRUCTIONS

Chapter 9B, Title 40, *Code of Alabama 1975*, provides for an abatement of all state and local noneducational property taxes, all construction related transaction taxes (sales and use taxes), except those local construction related transaction taxes levied for educational purposes or for capital improvements for education, and/or all mortgage and recording taxes relating to mortgages, deeds, and documents used to issue or secure obligations and convey title into or out of the name of a public authority, county or municipal government.

This form is to be submitted to the granting authority for consideration in granting an abatement of noneducational sales and use taxes, noneducational property taxes, and/or mortgage and recording taxes. **If you have any questions about this form or the abatement of taxes in general, please contact the Alabama Department of Revenue at (334) 242-1175.**

**A complete and detailed listing of project costs should be attached to this application in order for the granting authority to make a cost/benefit analysis in accordance with Section 40-9B-6(a).**

### STATUTORY REQUIREMENTS FOR ABATEMENTS

The following are qualifying business activities under Section 40-9B-3, *Code of Alabama 1975*:

- **Industrial or Research Enterprise** – Any trade or business in the 2007 North American Industrial Classification System (NAICS), promulgated by the Executive Office of the President of the United States, Office of Management and Budget as: Sectors 31 (except National Industry 311811), 32, 33, 55 (if not for the production of electricity), Subsectors 423, 424, 482, 493, 511, 517, 518, 927, Industry Groups 1133, 1212, 14862, 4882, 4883 (other than 48833) 5121 (other than 51213), 5415, 5417, Industries 22111, 48691, 48699, 48819, 51221, 51913, 52232, 54133, 54134, 54138, 56291, 56292, 92811, National Industries 115111, 221330, 541614, 561422 (in bound call centers only), 562213, and 611512.
- **Subsector 493, Industry Number 488310, or 488320** when such trade or business is conducted on premises in which the Alabama State Port Authority has an ownership, leasehold, or other possessory interest and such premises are used as part of the operations of the Alabama State Port Authority. These projects require written approval of the Governor, Finance Director, and the Director of the Alabama State Port Authority.
- **Headquarters Facility** – Any trade or business in the 2007 North American Industrial Classification System (NAICS), promulgated by the Executive Office of the President of the United States, Office of Management and Budget as National Industry 551114 at which at least 50 new jobs are located.
- **Data Processing Center** – An establishment, at which at least 20 new jobs are located, engaged in the provision of complete processing and specialized reports from data, the provision of automated data processing and data entry services, the provision of an infrastructure for hosting or data processing services, the provision of specialized hosting activities, the provision of application service provisioning, the provision of general time-share mainframe facilities, or some combination of the foregoing, without regard to whether any other activities are conducted at the establishment.
- **Research & Development Facility** – An establishment engaged in conducting original investigations undertaken on a systematic basis to gain new knowledge and/or applying research findings or other scientific knowledge to create new or significantly improved products or processes.
- **Renewable Energy Facility** – Any plant, property, or facility that either:
  1. Produces electricity or natural gas, in whole or in part, from biofuels as such term is defined in Section 2-2-90(c)(2) or from renewable energy resources as such term is defined in Section 40-18-1(30) with the exception that hydropower production shall be excluded from such definition; or
  2. Produces biofuel as such term is defined in Section 2-2-90(c)(2).
- **Alternative Energy Resources Electricity Production Project** - A project owned by a utility described in Section 37-4-1(7)a, Code of Alabama 1975, or owned by a company which is itself owned by a utility, at which the predominant trade or business activity conducted will be the production of electricity from alternative energy resources (coal gasification or liquefaction, nuclear and/or advanced fossil-based generation), the capital costs of which are not less than \$100,000,000.
- **Hydropower Electricity Production Project** - A project owned by a utility described in Section 37-4-1(7)a, or owned by a company which is itself owned by a utility, at which the predominant trade or business activity conducted will be the production of electricity from hydropower production as defined in Section 40-18-1(16), the capital costs of which are not less than \$5,000,000.
- **Tourist Destination Attractions** – A commercial enterprise which is open to the public not less than 120 days during a calendar year and is designed to attract visitors from inside or outside of the State of Alabama, typically for its inherent cultural value, historical significance, natural or man-made beauty, or entertainment or amusement opportunities. The term shall include, but not be limited to, a cultural or historical site; a botanical garden; a museum; a wildlife park or aquarium open to the public that cares for and displays a collection of animals or fish; an amusement park; a convention hotel and conference center; a water park; or a spectator venue or arena.
- **Any of the 11 targeted business sectors** under the Accelerate Alabama Strategic Economic Development Plan adopted in January 2012 by the Alabama Economic Development Alliance, created by Executive Order Number 21 of the Governor on July 18, 2011, which include Advanced Manufacturing in Aerospace/Defense, Automotive, Agricultural Products/Food Production, Steel/Metal, Forestry Products and Chemicals; Technology in Biosciences, Information Technology, Enabling Technologies; Distribution/Logistics and Corporate Operations.

## LINE BY LINE INSTRUCTIONS

**Item 1a.** Indicate the type(s) of abatement(s) being requested.

**Sales and Use Taxes** – Chapter 9B, Title 40, *Code of Alabama 1975*, provides for the abatement of certain noneducational sales and use taxes imposed by Chapter 23 of Title 40, *Code of Alabama 1975*. The abatement applies to the tangible personal property and taxable services incorporated into the project, the cost of which may be added to the capital account with respect to the project. However, only the state and local noneducational sales and use taxes may be abated. No sales and use tax abatement shall extend beyond the date the project is placed in service.

**Property Taxes** – Chapter 9B, Title 40, *Code of Alabama 1975*, provides for the abatement of noneducational property taxes imposed by the state, counties, municipalities and other taxing jurisdictions in Alabama. Only industrial property not previously placed in service in Alabama by the user or a related party may be eligible for an abatement of noneducational property taxes.

**Mortgage And Recording Taxes** – Chapter 9B, Title 40, *Code of Alabama 1975*, provides for the abatement of all taxes imposed by Chapter 22 of Title 40 of the *Code of Alabama 1975*, relating to mortgages, deeds, and documents used to issue or secure obligations and convey title into or out of the name of a public authority.

**Item 1b.** Indicate if applicant is requesting abatement of property taxes for a period longer than 10 years. For any property tax abatement that is granted for over 10 years, the noneducational municipal taxes can only be abated by the City Government, noneducational county taxes can only be abated by the County Government, and state taxes can only be abated by the Governor. The governing body of the municipality and county can authorize a public industrial authority to provide by resolution for such consent on its behalf.

**Item 2.** If the predominant business activity is a headquarters facility, an industrial or research enterprise as defined in *Code of Alabama 1975* Section 40-9B-3(10)(a) or a state docks project as defined in Section 40-9B-3(10)(b), enter the 2007 North American Industrial Classification System (NAICS) code for the project.

**Item 3.** Indicate if project is a new project or a major addition.

**New Project** – Any new business in Alabama at which the predominant trade or business activity conducted will constitute an industrial or research enterprise or other qualifying business activity as described above. If new project, skip Item 4.

**Major Addition** – Pursuant to Section 40-9B-3(11), a major addition is an addition to an existing facility in which the addition equals the lesser of thirty (30) percent of the original cost of the existing land, buildings, and equipment (industrial development property), or \$2,000,000, and at which the predominant trade or business activity conducted in Alabama will constitute an industrial or research enterprise or other qualifying business activity as described above. Capitalized repairs, rebuilds, maintenance, replacement equipment, or costs associated with the renovating or remodeling of existing facilities of industrial development property previously placed in service in Alabama by the Company are not eligible for abatement under Chapter 9B.

**Item 4.** Indicate if major addition is in accordance with Section 40-9B-3(11) requirement as denoted above. If major addition does not meet threshold requirement, project is not qualified to receive abatement. Original cost should include the total cost of existing facilities as of the date of application.

**Item 5.** Enter the name of the private user requesting abatement. If project is doing business under another name, also enter the name of the company under "Doing Business As (DBA)."

**Item 6.** Enter the address of the private user requesting abatement.

**Item 7.** Enter the name, email address and telephone number of the person to which all correspondence should be directed regarding the abatement.

**Item 8.** Enter the date the company was organized.

**Item 9.** Enter the physical location of the project. Please include a detailed location, including the City, County and Zip Code.

**Item 10.** Describe the type of business that the project will be engaged in. For projects that do not require a NAICS code, provide a detailed description that will identify the activities as qualifying activities. Attach additional sheets if necessary.

**Item 11.** Enter the estimated date the construction of the project will begin.

**Item 12.** Enter the estimated date the construction of the project will be completed. A data processing center project's completion date will be the maximum exemption period allowed pursuant to Section 40-9B-3(12)b.

**Item 13.** Enter the estimated date the project will be placed in service. If revenue bonds are issued, "placed in service," for property tax purposes, is determined as of the date of the initial issuance of such bonds. Otherwise, with the exception of a data processing center project, "placed in service" for sales and use tax and property tax purposes is determined as the later of 1) the date on which title to the property was acquired by or vested in a county, city, or public authority, or 2) the date on which the property is or becomes owned, for federal income tax purposes, by a private user. A data processing center project's placed in service date will be the maximum exemption period allowed pursuant to Section 40-9B-3(12)b.

**Item 14.** Indicate if bonds have been issued in financing the project. If bonds have been issued, enter the issuance date.

**Item 15.** Indicate if bonds will be issued for financing the project. If bonds will be issued, enter the projected issuance date.

**Column 16.** Enter the estimated number of new employees to be hired at the project. The law requires the number of employees to be employed at the project initially and in each of the succeeding three years.

**Column 17.** Enter the estimated annual payroll for employees at the project. The law requires the estimated payroll of new employees initially and in each of the succeeding three years.

**Column 18.**

**18a.** Enter all costs or value for project land. If land is donated, enter the market value of the land.

**18b.** Enter all costs or value for existing building(s), if any.

**18c.** Enter all costs or value for existing personal property to be incorporated into project. Only personal property not previously placed in service in Alabama by the private user or a related party can be included. If a private user is including existing equipment from outside of Alabama, the existing equipment should be entered here at its original cost.

**18d.** Enter the total cost for new building(s) and/or new additions to existing building(s). Total cost includes building materials, construction costs, engineering costs, etc. Costs associated with renovating or remodeling existing facilities of an operating industrial or research enterprise do not qualify for abatement.

**18e.** Enter the total cost for new manufacturing equipment to be incorporated into the project. Replacement equipment does not qualify for abate-

er Chapter 9B. New equipment that is defined as upgraded equipment qualify. Upgraded equipment is equipment that replaces existing equipment, and performs not only the same functions, but also an additional function.

**18f.** Enter the total cost for all other new personal property. Other new personal property may include, but is not limited to, non-manufacturing machinery, office equipment, computers, vehicles, etc. Only personal property that is a depreciable item can be included.

**18g.** Add 18a through 18f and enter total here. This is the total amount on which the initial property taxes will be based. This total must be the total value of the cost or investment in the project. This total must agree with the total investment amount in the abatement resolution and the total investment amount in the abatement agreement.

**Column 19.**

**19d.** Enter the cost of the building materials (subject to sales tax) that become a part of realty for new building(s) and/or new additions to existing building(s). Other building costs (labor, engineering) are not subject to sales tax.

**19e.** Enter the cost of new manufacturing equipment for the project. For sales tax purposes, manufacturing equipment is taxed at a lower rate. Equipment that is purchased used from another company in an isolated transaction is not subject to sales tax and should not be included.

**19f.** Enter the cost of all other new personal property.

**19g.** Add 19d through 19f and enter total here.